

HPL35 WRECKER

PARTS MANUAL

JERR-DAN[®]

An Oshkosh Corporation Company

1080 Hykes Road
Greencastle, PA 17225
Phone (717) 597-7111
www.jerr-dan.com

5-376-000112
Rev 02 - July 01, 2010

© 2010 Jerr-Dan Corporation. All Rights Reserved.

This manual covers the following Jerr-Dan Models:

HPL35 Wrecker

Jerr-Dan Corporation strives to provide information that is accurate, complete and useful. Descriptions and illustrative material contained within this manual are as accurate as known at the time of publication and are subject to change, without notice, as a result of continuous product improvements. Jerr-Dan reserves the right to amend the information in this document at any time without prior notice.

Information contained in this manual reflects how this vehicle was built at the factory. Modifications or additions by the distributor or owner are not reflected in this manual.

This parts manual does not include service parts information for the commercial chassis (IHC, Ford, GM, etc.). That information is provided by the chassis manufacturer.

When ordering parts, please refer to your unit's Sales Order Number, Serial Number and Model Number. This information is be found on the aluminum tag riveted to the inside of the driver's side toolbox of the main body.



Additional or replacement manuals can be ordered by calling Jerr-Dan Parts at 717-597-7111. Price and availability will be quoted at time of the request.

Please report comments and/or errors by contacting Jerr-Dan Corporation's Technical Publications Department by e-mail at technicalpublications@jerr-dan.com or by FAX on 717-593-2362.

Manufactured under one or more of the following patents: 5,575,606; 5,672,042; 5,697,741; 5,713,714; 5,722,810; 5,782,596; 5,839,775 and 6,315,515 B1 with other Patents Pending.

Jerr-Dan and the Jerr-Dan logo are registered trademarks and Run Hard is a service mark of Jerr-Dan Corporation, Greencastle, PA USA.

The material in this document is confidential and the property of Jerr-Dan Corporation. No part of this document may be photocopied, reproduced or translated to another language without the express written consent of Jerr-Dan Corporation.

INDEX

DESCRIPTION	PAGE	DESCRIPTION	PAGE
Body - Aluminum -Complete	4 - 5	Fender Flares	106 - 107
Body Assembly - Aluminum	6 - 9	Headboard - Body Mount	108 - 109
Body - Steel -Complete	10 - 11	Headboard - Toolbox Mount	110 - 111
Body Assembly - Steel - 60"	12 - 13	Tow Sling	112 - 113
Body Assembly - Steel - 84"	14 - 15	Self-Loading Dolly	114 - 115
Subframe	16 - 18	Decals	116 - 117
Hydraulic Reservoir	20 - 21	Forks and Adapters	118 - 119
Tunnel Toolbox - 22" & 24" Aluminum - Foreign	22 - 23	Switch Panel	120 - 121
Tunnel Toolbox - 48" Aluminum - Foreign	24 - 25	Lightbar	122 - 123
Tunnel Toolbox - 24" Aluminum - Ford, IHC & GMC	26 - 27	Fold Down Lightbar Bracket	124 - 125
Tunnel Toolbox - 22" & 24" Steel - Foreign	28 - 29	Chain and Straps	126 - 127
Tunnel Toolbox - 24" Steel - Ford, IHC & GMC	30 - 31	Jump Start Kit	128 - 129
Deck Mounted 8,000 lb Recovery Winch	32 - 33	Wheel Chocks	130 - 131
Deck Mounted Recovery Winch Cable Tensioner	34 - 35	Stone Guard - Tunnel Toolbox	132 - 133
4 Ton Wrecker Boom - Single 8,000 lb Winch	36 - 39	Battery Box - Tunnel ToolBox	134 - 135
8 Ton Wrecker Boom - Single 8,000 lb Winch	40 - 43	Pull-Out Drawer - Tunnel ToolBox	136 - 137
8 Ton Wrecker Boom - Dual 8,000 lb Winch	44 - 47	Ford Diesel 08 Exhaust Alteration	138 - 139
12 Ton Wrecker Boom - Single 10,000 lb Winch	48 - 51	Dodge Diesel 08 Exhaust Alteration	140 - 141
12 Ton Wrecker Boom - Dual 10,000 lb Winch	52 - 55	Foreign Chassis Lights and Wiring	142 - 143
12 Ton Wrecker Boom - Dual 12,000 lb Winch	56 - 59	Fuel Fill	144 - 145
Wrecker Boom Single / Dual Winch - Cable Tensioner	60 - 61		
Winch Mounted Light Pylon	62 - 63		
8 / 12 Ton Dual Winch Free Spool	64 - 65		
Underlift Boom -Complete	66 - 67		
Underlift Boom Assembly	68 - 69		
Manual L-Arm Wheel Lift Grid and Storage	70 - 71		
Manual T37 Pivoting Wheel Lift Grid and Storage	72 - 73		
Hydraulic Components - PTO Version +	74 - 75		
Dual Controls - 3 Bank	76 - 77		
Dual Controls - 4 Bank	78 - 79		
Dual Controls - 6 Bank	80 - 81		
Dual Controls - 7 bank	82 - 83		
Electrical Components - Standard Lights and Wiring	84 - 85		
Electrical Components - Optional Lights and Wiring	86 - 87		
Electrical Components - Tail Light Converter	88 - 89		
Wheellift Boom Elevation Cylinder Assembly	90 - 91		
Wheellift Boom Tilt Cylinder Assembly	92 - 93		
Wrecker Boom Tilt Cylinder Assembly - 4 Ton	94 - 95		
Wrecker Boom Extension Cylinder Assembly - 4 Ton	96 - 97		
Wrecker Boom Tilt Cylinder Assembly - 8 / 12 Ton	98 - 99		
Wrecker Boom Extension Cylinder Assembly - 8 / 12 Ton	100 - 101		
Remote Control Operation	102 - 103		
Mud Flaps	104 - 105		

BODY - ALUMINUM -COMPLETE

ITEM	PART NO.	DESCRIPTION	QTY
1	3502080179	60" Body Assembly (60" CA) (no toolboxes)	1
	3502080181	60" Body Assembly (84" CA) (no toolboxes)	
	3502080177	60" Body Assembly (60" CA) (left side toolbox)	
	3502080180	60" Body Assembly (84" CA) (left side toolbox)	
	3502080178	60" Body Assembly (60" & 84" CA) (left & right side toolbox)	
2	4706000717	Plate	4
3	7660162601	Locknut, 0.38"-16NC	4
4	3708000002	Chain Box Weld, LH	1
5	3708000003	Chain Box Weld, RH	1
6	7115181450	Capscrew, 0.50"-13NC x 1.75"	8
7	7660182301	Locknut, 0.50"-13NC	8
8	4178000186	Bracket (body w/ no toolboxes)	2
	4178000186	Bracket (body w/ left side toolbox)	1
9	7115140850	Capscrew, 0.25"-20NC x 1.00" (body w/ no toolboxes)	2
	7115140850	Capscrew, 0.25"-20NC x 1.00" (body w/ left side toolbox)	1
10	7950140161	Flatwasher, 0.25" ID (body w/ no toolboxes)	2
	7950140161	Flatwasher, 0.25" ID (body w/ left side toolbox)	1
11	7660142600	Locknut, 0.25"-20NC (body w/ no toolboxes)	2
	7660142600	Locknut, 0.25"-20NC (body w/ left side toolbox)	1

BODY - ALUMINUM -COMPLETE

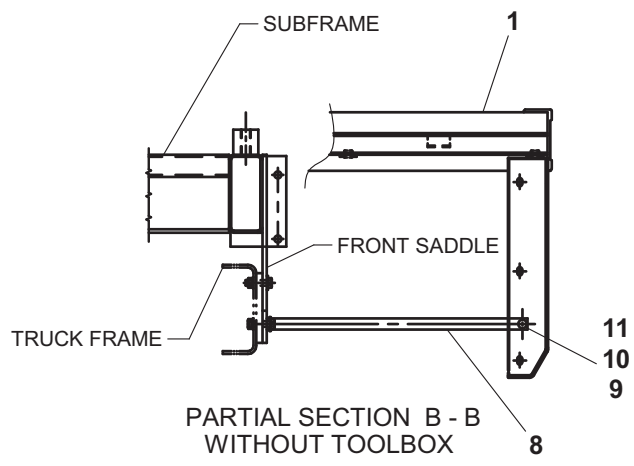
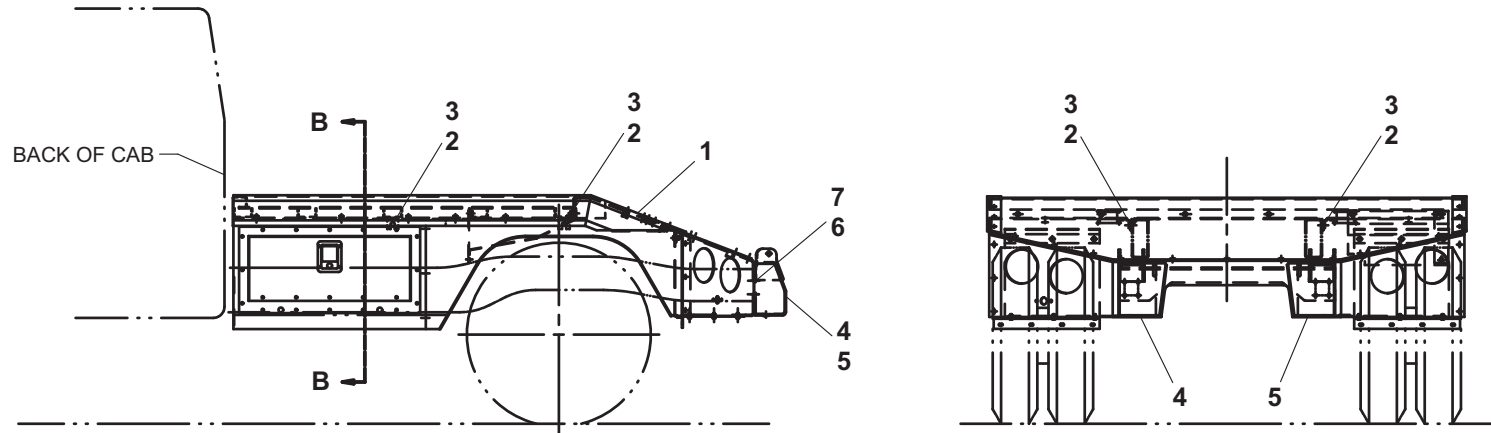

BODY ASSEMBLY - ALUMINUM

ITEM	PART NO.	DESCRIPTION	QTY	ITEM	PART NO.	DESCRIPTION	QTY
1	3512300117	Deck Weld (aluminum)	1	20	7950160161	Flatwasher, 0.38" ID	48
2	3686000005	Body Panel Weld- LH (no toolboxes) (60" CA)	1		7950160161	Flatwasher, 0.38" ID (no toolboxes)	50
	4686000030	Side Panel - LH (no toolboxes) (84" CA)			7950160161	Flatwasher, 0.38" ID (left side toolbox only)	
	3899000018	Toolbox Weld- LH (left side toolbox only)			7950160161	Flatwasher, 0.38" ID (left & right side toolbox only)	
3	3686000004	Body Panel Weld- RH (no toolboxes or left side toolbox only) (60" CA)	1	21	7950160000	Lockwasher, 0.38" ID (no toolboxes)	20
	4686000031	Side Panel - RH (no toolboxes or left side toolbox only) (84" CA)			7950160000	Lockwasher, 0.38" ID (left side toolbox only)	22
	3899000017	Toolbox Weld- RH (left & right side toolbox)			7950160000	Lockwasher, 0.38" ID (left & right side toolbox only)	24
4	4679000070	Pad- LH (left side toolbox)	1				
5	4679000069	Pad- RH (right side toolbox)	1	22	7413000002	Nutsert, 0.25"-20NC	12
6	4415000049	Fender- LH	1	23	7115140850	Capscrew, 0.25"-20NC x 1.00"	3
7	4415000048	Fender- RH	1	24	4706001333	Plate	1
8	3502300022	Tail Weld- LH	1	25	4706001334	Plate	1
9	3502300021	Tail Weld- RH	1	26	4706001519	Plate	1
10	4706002282	Plate	1	27	7950140000	Lockwasher, 0.25" ID	12
11	7701000003	Plug	3	28	3502300054	Tail Plate Weld	1
12	7111140650	Capscrew, 0.25"-20NC x 0.75"	9	29	8632000018	Edge Trim	18in
13	4706002286	Plate	1	30	7189000007	Bumper (left side toolbox only)	2
14	7660162601	Locknut, 0.38"-16NC	7		7189000007	Bumper (left & right side toolbox only)	4
15	7114140818	Capscrew, 0.25"-20NC x 1.00"	21	31	4411000001*	Seal Channel - Top (left side toolbox only)	1
16	7115161050	Capscrew, 0.38"-16NC x 1.25" (no toolboxes)	27		4411000001*	Seal Channel - Top (left & right side toolbox only)	2
	7115161050	Capscrew, 0.38"-16NC x 1.25" (left side toolbox only)	29	32	4411000002*	Seal Channel - Left (left side toolbox only)	1
	7115161050	Capscrew, 0.38"-16NC x 1.25" (left & right side toolbox only)	31		4411000002*	Seal Channel - Left (left & right side toolbox only)	2
				33	4411000003*	Seal Channel - Right (left side toolbox only)	1
17	7114141023	Capscrew, 0.25"-20NC x 1.25"	6		4411000003*	Seal Channel - Right (left & right side toolbox only)	2
18	7660142600	Locknut, 0.25"-20NC	27				
19	7950140161	Flatwasher, 0.25" ID	35				

* included in Door & Frame Assembly, P/N 3455000001

BODY ASSEMBLY - ALUMINUM

ITEM	PART NO.	DESCRIPTION	QTY	ITEM	PART NO.	DESCRIPTION	QTY
34	4411000053*	Seal Channel - Bottom (left side toolbox only)	1	46	7114140818*	Capscrew, 0.25"-20NC x 1.00" (left side toolbox only)	21
	4411000053*	Seal Channel - Bottom (left & right side toolbox only)	2		7114140818*	Capscrew, 0.25"-20NC x 1.00" (left & right side toolbox only)	42
35	4706000022*	Plate (left side toolbox only)	2	47	7949000056*	Nylon Washer, 0.25" ID (left side toolbox only)	21
	4706000022*	Plate (left & right side toolbox only)	4		7949000056*	Nylon Washer, 0.25" ID (left & right side toolbox only)	42
36	4411000004*	Hinge (left side toolbox only)	1		7949000056*	Nylon Washer, 0.25" ID (left & right side toolbox only)	42
	4411000004*	Hinge (left & right side toolbox only)	2				
37	4706000023*	Door (left side toolbox only)	1	48	7661000062*	Locknut, 0.25"-20NC (left side toolbox only)	16
	4706000023*	Door (left & right side toolbox only)	2		7661000062*	Locknut, 0.25"-20NC (left & right side toolbox only)	32
38	4763000003*	Hinge Rod (left side toolbox only)	1				
	4763000003*	Hinge Rod (left & right side toolbox only)	2				
39	7585000012*	T-Handle Latch (left side toolbox only)	1	49	3455000001	Door & Frame Assembly (left side toolbox only)	1
	7585000012*	T-Handle Latch (left & right side toolbox only)	2		3455000001	Door & Frame Assembly (left & right side toolbox only)	1
40	7796000084*	Gasket (left side toolbox only)	1				
	7796000084*	Gasket (left & right side toolbox only)	2	50	7660142601*	Locknut, 0.25"-20NC (left side toolbox only)	5
41	7796000002*	Seal (left side toolbox only)	60in		7660142601*	Locknut, 0.25"-20NC (left & right side toolbox only)	10
	7796000002*	Seal (left & right side toolbox only)	120in				
42	7114080418*	Capscrew, #8-32 NC x 0.50" (left side toolbox only)	4				
	7114080418*	Capscrew, #8-32 NC x 0.50" (left & right side toolbox only)	8				
43	7660082500*	Locknut, #8-32NC (left side toolbox only)	4				
	7660082500*	Locknut, #8-32NC (left & right side toolbox only)	8				
44	4706003611*	Plate (left side toolbox only)	1				
	4706003611*	Plate (left & right side toolbox only)	2				
45	7759000017*	Rivet (left side toolbox only)	2				
	7759000017*	Rivet (left & right side toolbox only)	4				

* included in Door & Frame Assembly, P/N 3455000001

BODY ASSEMBLY - ALUMINUM

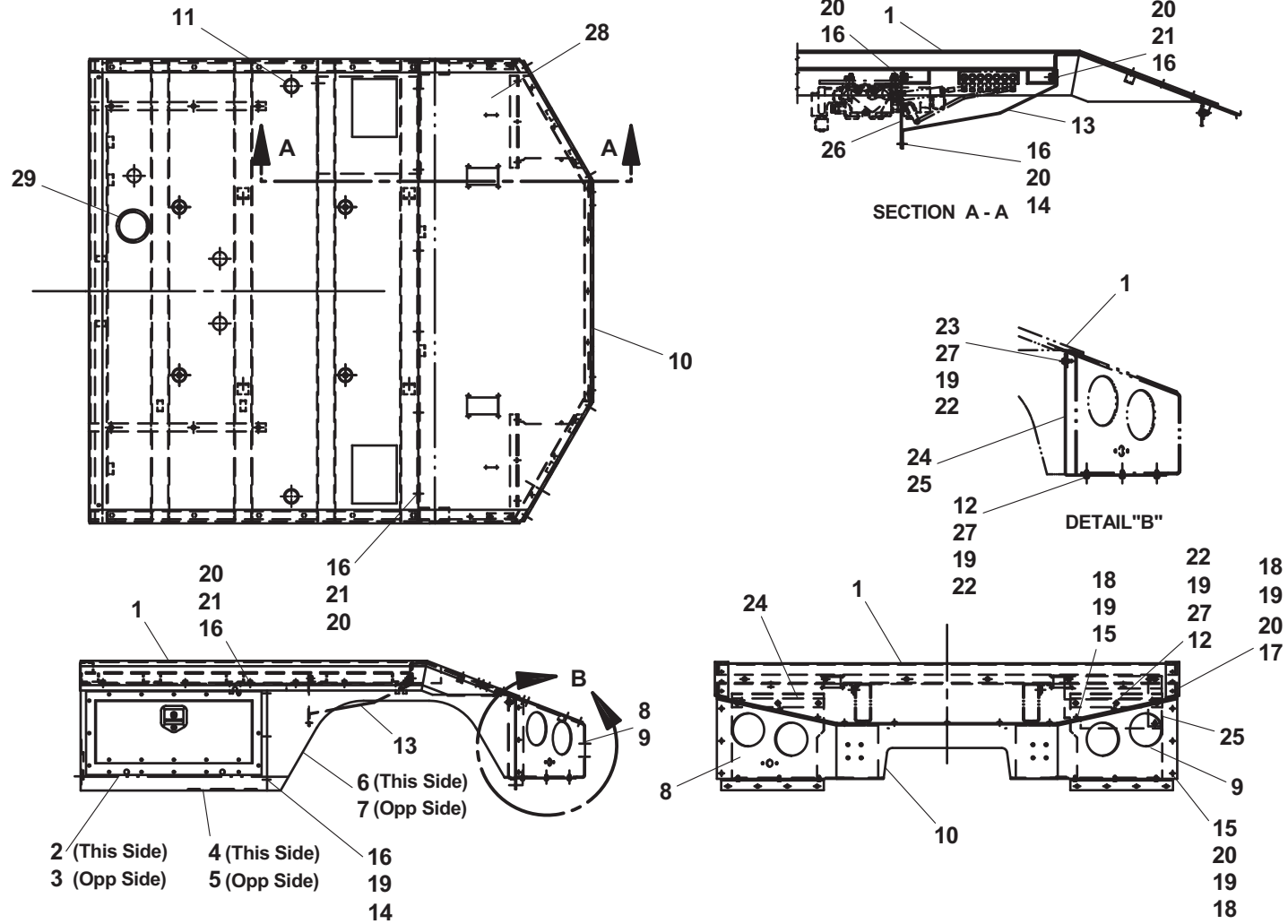

See page 9 for Toolbox part number callouts

BODY ASSEMBLY - ALUMINUM

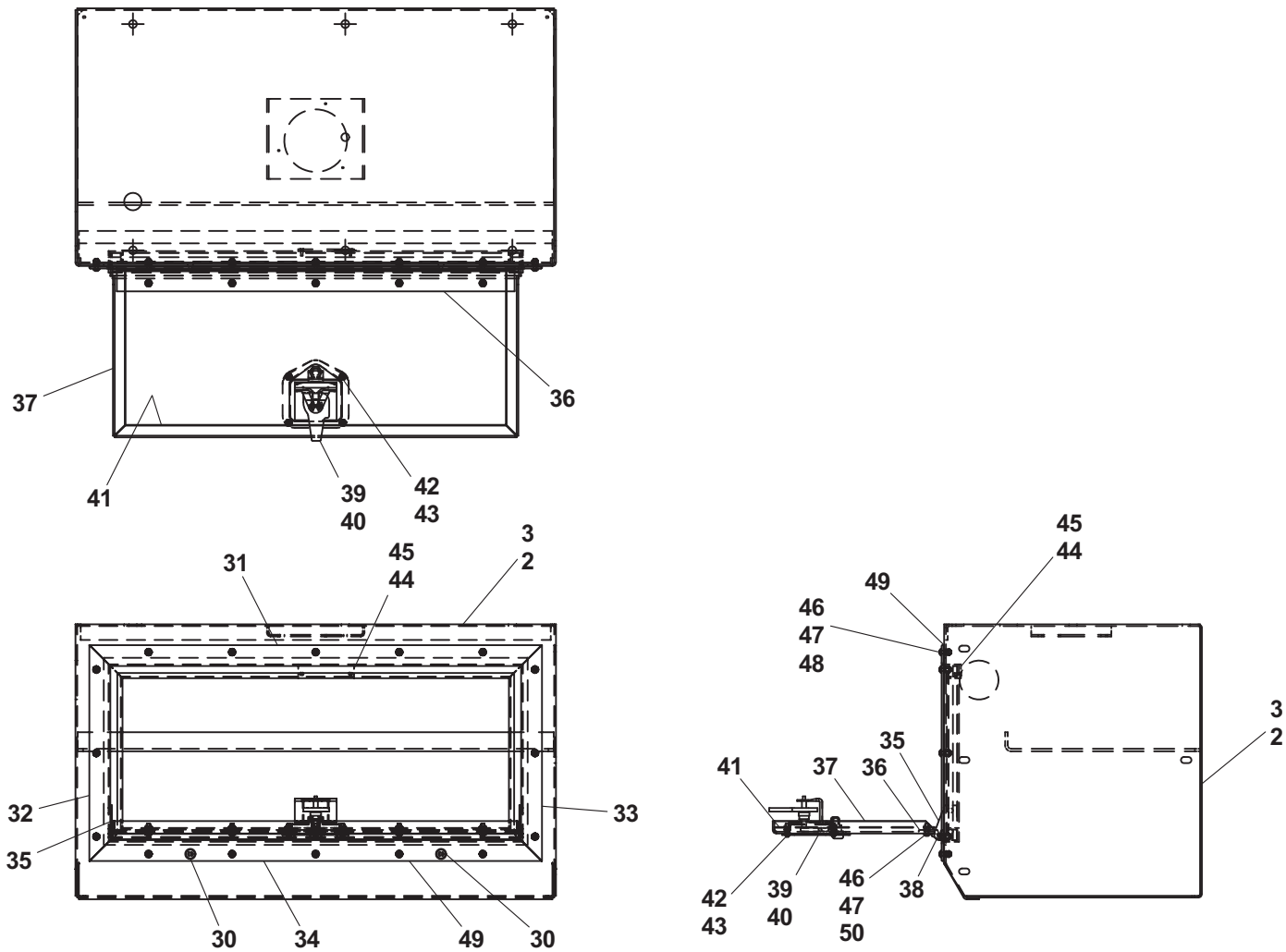

BODY - STEEL - COMPLETE

ITEM	PART NO.	DESCRIPTION	QTY
1	3502080182	60" Body Assembly (60" & 84" CA) (left side toolbox)	1
	3502080183	60" Body Assembly (60" & 84" CA) (left & right side toolbox)	
	3502080184	84" Body Assembly (84" CA) (left & right side toolbox)	
2	4706000717	Plate	4
3	7660182601	Locknut, 0.50"-13NC	4
4	7115181450	Capscrew, 0.50"-13NC x 1.75"	8
5	7660182301	Locknut, 0.50"-13NC	8
6	4706001516	Plate	1
7	4178000186	Bracket (body w/ left side toolbox)	1
8	7790141056	Screw, 0.25"-20NC x 0.63"	2
9	7111140850	Capscrew, 0.25"-20NC x 1.00" (body w/ left side toolbox)	2
	7111140850	Capscrew, 0.25"-20 NC x 1.00" (body w/ left & right side toolbox)	1
10	7950140161	Flatwasher, 0.25" ID (body w/ left side toolbox)	2
	7950140161	Flatwasher, 0.25" ID (body w/ left & right side toolbox)	1
11	7660142600	Locknut, 0.25"-20NC (body w/ left side toolbox)	2
	7660142600	Locknut, 0.25"-20NC (body w/ left & right side toolbox)	1
12	4017000553	Angle (84" body)	2
13	7120000016	Capscrew, 0.50"-13NC x 1.25" (84" body)	4
14	7661000011	Locknut, 0.50"-13NC (84" body)	4

BODY - STEEL - COMPLETE

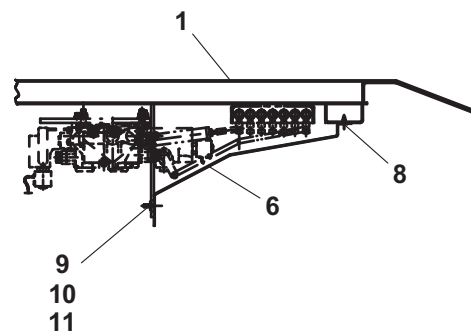
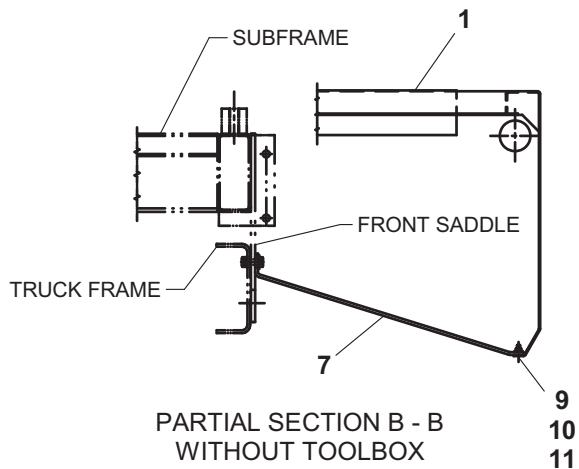
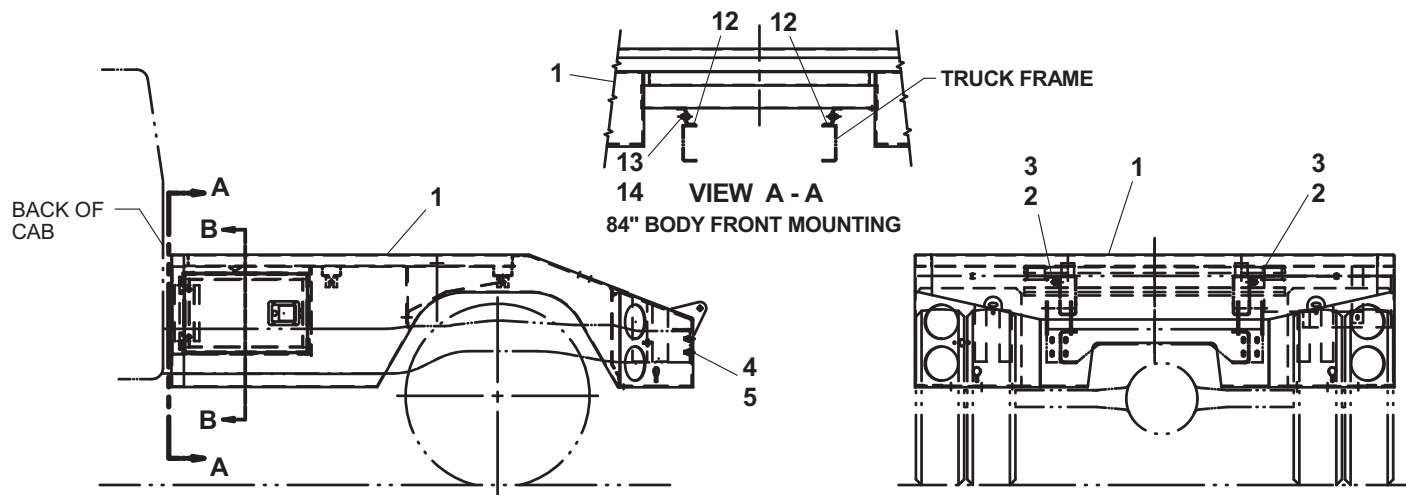

BODY ASSEMBLY - STEEL - 60"

ITEM	PART NO.	DESCRIPTION	QTY
1	3097000534	Deck Weld (steel) (left side toolbox)	1
	3097000535	Deck Weld (steel) (left & right side toolbox)	
2	4679000087	Pad (left side toolbox)	1
3	7701000003	Plug	2
4	7595000002	Paddle Handle (left side toolbox only)	1
	7595000002	Paddle Handle (left & right side toolbox only)	2
5	7796000031	Gasket (left side toolbox only)	1
	7796000031	Gasket (left & right side toolbox only)	2
6	7114080418	Capscrew, #8-32NC x 0.50" (left side toolbox only)	4
	7114080418	Capscrew, #8-32NC x 0.50" (left & right side toolbox only)	8
7	7660082500	Locknut, #8-32NC (left side toolbox only)	4
	7660082500	Locknut, #8-32NC (left & right side toolbox only)	8
8	3502300022	Door Weld (left side toolbox only)	1
	3502300022	Door Weld (left & right side toolbox only)	2
9	7118160516	Capscrew, 0.38"-16NC x 0.63" (left side toolbox only)	2
	7118160516	Capscrew, 0.38"-16NC x 0.63" (left & right side toolbox only)	4
10	7660162301	Locknut, 0.38"-16NC (left side toolbox only)	2
	7660162301	Locknut, 0.38"-16NC (left & right side toolbox only)	4
11	8632000018	Edge Trim	18in
12	4679000084	Pad (right side toolbox)	1

BODY ASSEMBLY - STEEL - 60"

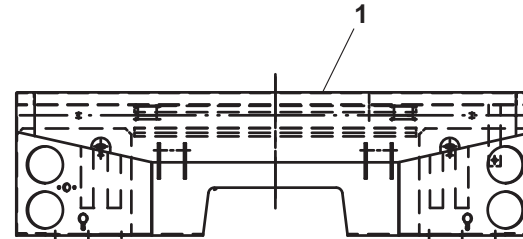
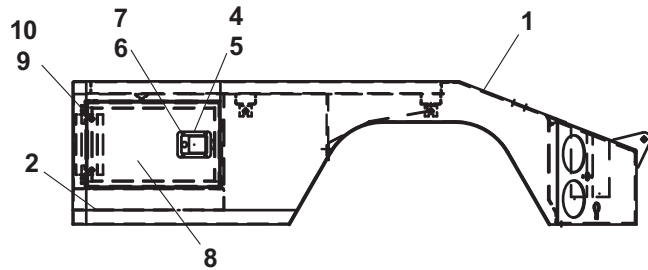
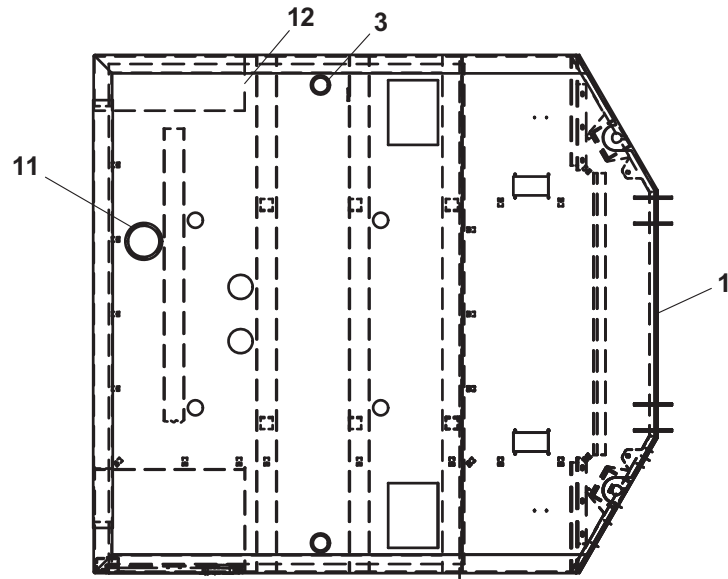

BODY ASSEMBLY - STEEL - 84"

ITEM	PART NO.	DESCRIPTION	QTY
1	3097000536	Deck Weld (steel) (84")	1
2	4679000080	Pad (left side toolbox)	1
3	4679000081	Pad (right side toolbox)	1
4	4679000082	Pad (center toolbox)	1
5	4679000083	Pad (right side toolbox)	1
6	4679000092	Pad (center deck)	1
7	7701000003	Plug	3
8	7595000002	Paddle Lock Handle	2
9	7595000001	Paddle Handle	2
10	7796000031	Gasket	4
11	7114080418	Capscrew, #8-32NC x 0.50"	16
12	7660082500	Locknut, #8-32NC	16
13	3706000039	Door Weld	2
14	3706000040	Door Weld	2
15	7759000001	Rivet	16
16	7118160516	Capscrew, 0.38"-16NC x 0.63"	8
17	7660162301	Locknut, 0.38"-16NC	8
18	4763000160	Lock Rod	4
19	8632000018	Edge Trim	18in

BODY ASSEMBLY - STEEL - 84"

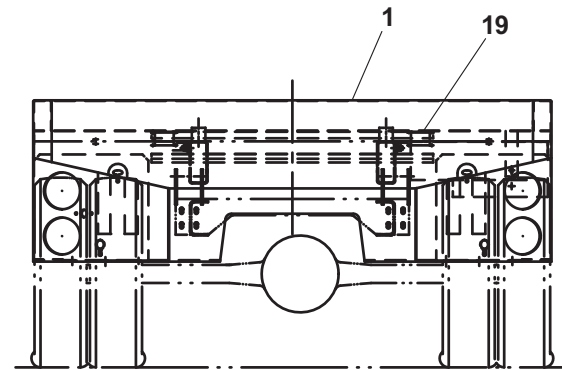
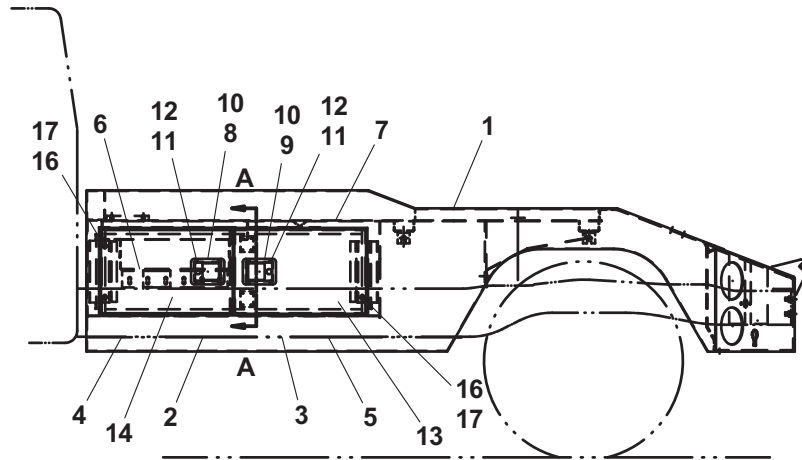
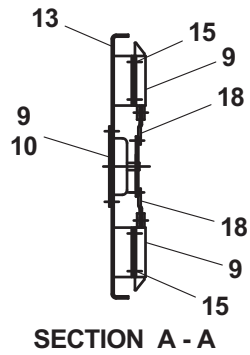

SUBFRAME

ITEM	PART NO.	DESCRIPTION	QTY	ITEM	PART NO.	DESCRIPTION	QTY
Ford F-Series				Dodge (60" CA)			
1	3502700230	Subframe Weld	1	1	3502700230	Subframe Weld	1
2	4017000387	Angle	1	2	4017000387	Angle	1
3	4706005903	Plate	1	3	4706005904	Plate	2
4	4706005904	Plate	1	4	Not Required		
5	4811001194	Plate	2	5	Not Required		
6	7115181650	Capscrew, 0.50"-13NC x 2.00"	20	6	7115181650	Capscrew, 0.50"-13NC x 2.00"	20
7	7950180153	Flatwasher, 0.50" ID	20	7	7950180153	Flatwasher, 0.50" ID	20
8	7660182601	Locknut, 0.50"-13NC	20	8	7660182601	Locknut, 0.50"-13NC	20
9	Not Required			9	Not Required		
10	Not Required			10	Not Required		
11	Not Required			11	Not Required		
12	Not Required			12	4706005633	Plate	2
Ford F-Series with 19,000 lb GVWR				Dodge (84" CA)			
1	3502700230	Subframe Weld	1	1	3502700230	Subframe Weld	1
2	4017000387	Angle	1	2	4017000387	Angle	1
3	4706005903	Plate	1	3	4706005904	Plate	2
4	4706005904	Plate	1	4	Not Required		
5	4811001194	Plate	2	5	4811001194	Plate	2
6	7115181650	Capscrew, 0.50"-13NC x 2.00"	20	6	7115181650	Capscrew, 0.50"-13NC x 2.00"	20
7	7950180153	Flatwasher, 0.50" ID	20	7	7950180153	Flatwasher, 0.50" ID	20
8	7660182601	Locknut, 0.50"-13NC	20	8	7660182601	Locknut, 0.50"-13NC	20
9	4706005907	Plate	1	9	Not Required		
10	4706005906	Plate	2	10	Not Required		
11	4706000718	Plate	2	11	Not Required		
12	Not Required			12	4706005633	Plate	2

SUBFRAME

ITEM	PART NO.	DESCRIPTION	QTY	ITEM	PART NO.	DESCRIPTION	QTY
		GM C3500				GM C4500/C5500 without Mid Tank	
1	3502700230	Subframe Weld	1	1	3502700230	Subframe Weld	1
2	4017000387	Angle	1	2	4017000387	Angle	1
3	4706005904	Plate	2	3	4706005951	Plate	2
4	Not Required			4	Not Required		
5	Not Required			5	Not Required		
6	7115181650	Capscrew, 0.50"-13NC x 2.00"	20	6	7115181650	Capscrew, 0.50"-13NC x 2.00"	20
7	7950180153	Flatwasher, 0.50" ID	20	7	7950180153	Flatwasher, 0.50" ID	20
8	7660182601	Locknut, 0.50"-13NC	20	8	7660182601	Locknut, 0.50"-13NC	20
9	Not Required			9	4812000114	Shim	2
10	Not Required			10	Not Required		
11	Not Required			11	Not Required		
12	4706005633	Plate	2	12	4812000115	Shim	2
		GM C4500/C5500 with Mid Tank					
1	3502700230	Subframe Weld	1				
2	4017000387	Angle	1				
3	4706005951	Plate	2				
4	Not Required						
5	Not Required						
6	7115181650	Capscrew, 0.50"-13NC x 2.00"	20				
7	7950180153	Flatwasher, 0.50" ID	20				
8	7660182601	Locknut, 0.50"-13NC	20				
9	4812000114	Shim	1				
10	Not Required						
11	Not Required						
12	4812000115	Shim	2				

SUBFRAME

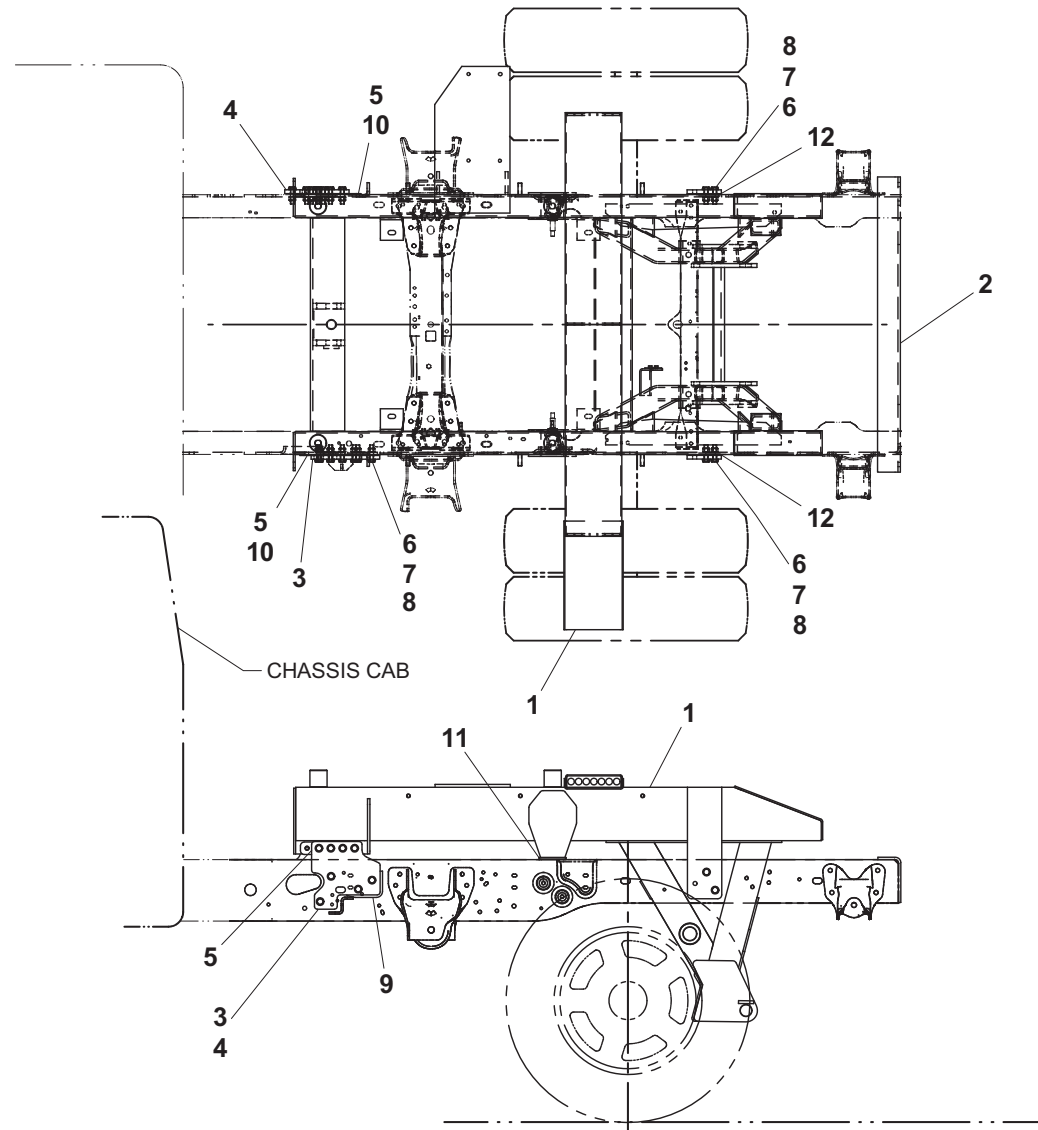

THIS PAGE INTENTIONALLY LEFT BLANK

HYDRAULIC RESERVOIR

ITEM	PART NO.	DESCRIPTION	QTY
1	3750000057	Reservoir Weld	1
2	7950180161	Flatwasher, 0.50" ID	4
3	7660182601	Locknut, 0.50"-13NC	4
4	7444081070	Street Elbow	1
5	7443000013	Nipple	1
6	7701000026*	Magnetic Plug	1
7	7183000008*	Breather, Filler Cap	1

* also available in Reservoir Weld, P/N 3750000057

HYDRAULIC RESERVOIR

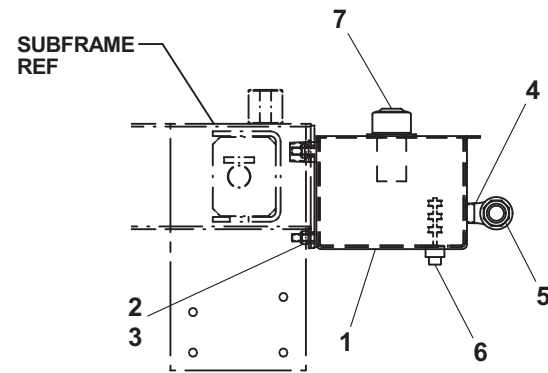
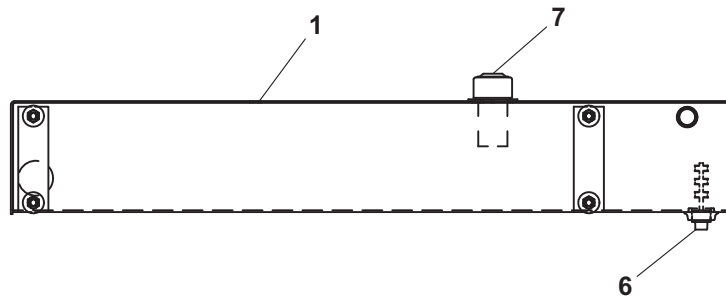
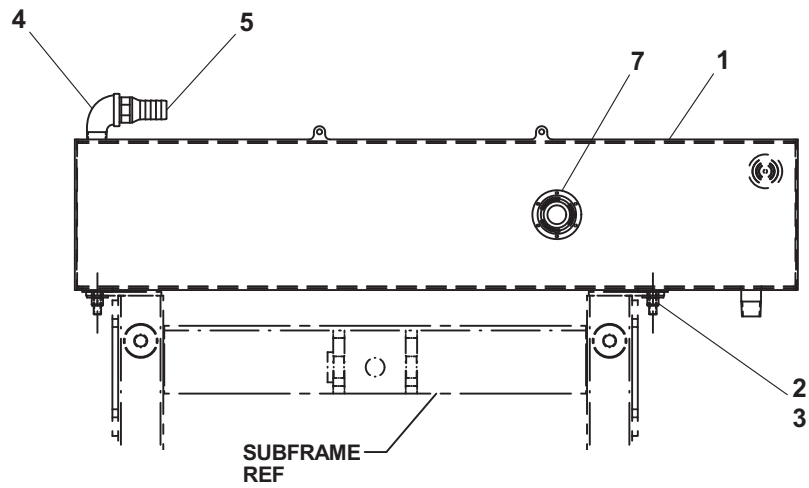

TUNNEL TOOLBOX - ALUMINUM - 22" & 24" FOREIGN

ITEM	PART NO.	DESCRIPTION	QTY	ITEM	PART NO.	DESCRIPTION	QTY
1	3899000080	Tunnel Toolbox Weld (22" wide)	1	29	7796000002	Seal	120in
	3899000028	Tunnel Toolbox Weld (24" wide)		30	7114080418	Capscrew, #8-32NC x 0.50"	8
2	3455000033	Frame Weld (22" wide)	1	31	7660082500	Locknut, #8-32NC	8
	3455000018	Frame Weld (24" wide)		32	4706003611	Plate	2
3	7115181450	Capscrew, 0.50"-13NC x 1.75"	4	33	7759000017	Rivet	4
4	7660182301	Locknut, 0.50"-13NC	4	34	7796000012	Seal	173in
5	7115161010	Capscrew, 0.38"-16NC x 1.25"	4	35	4686000144	Panel (22" wide)	2
6	7950160161	Flatwasher, 0.38" ID	4		4706000712	Plate (24" wide)	
7	7660162601	Locknut, 0.38"-16NC	4	36	7111160650	Capscrew, 0.38"-16NC x 0.75"	6
8	7189000010	Bumper	4	37	7413000003	Nutsert, 0.38"-16NC	6
9	3274000007	Clamp Weld	4	38	4812000047	Shim	4
10	7661000062	Nut, 0.25"-20NC	28	39	7949000056	Washer, 0.50" OD	34
11	7346000038	Grounding Strap	1	40	7660142601	Locknut, 0.25"-20NC	34
12		Not Required (22" Toolbox)					
	7790141076	Screw, 0.25" x 0.63" (24" Toolbox)	4				
13	7632046140	Moulding	140in				
14	4178000187	Bracket	4				
15	7114140611	Capscrew, 0.25"-20NC x 0.75"	4				
16	7950140153	Flatwasher, 0.25" ID	4				
17	7660142604	Locknut, 0.25"-20NC	4				
18	4411000124	Seal Channel - Top	2				
19	4411000089	Seal Channel - LH	2				
20	4411000090	Seal Channel - RH	2				
21	4411000125	Seal Channel - Bottom	2				
22	4706000022	Plate	4				
23	4411000091	Hinge	2				
24	4811000382	Door	2				
25	4763000153	Hinge Rod	2				
26	7585000012	T-Handle Latch	2				
27	7114140618	Capscrew, 0.25"-20NC x 0.75"	34				
28	7796000084	Gasket	2				

TUNNEL TOOLBOX - 22" & 24" ALUMINUM - FOREIGN

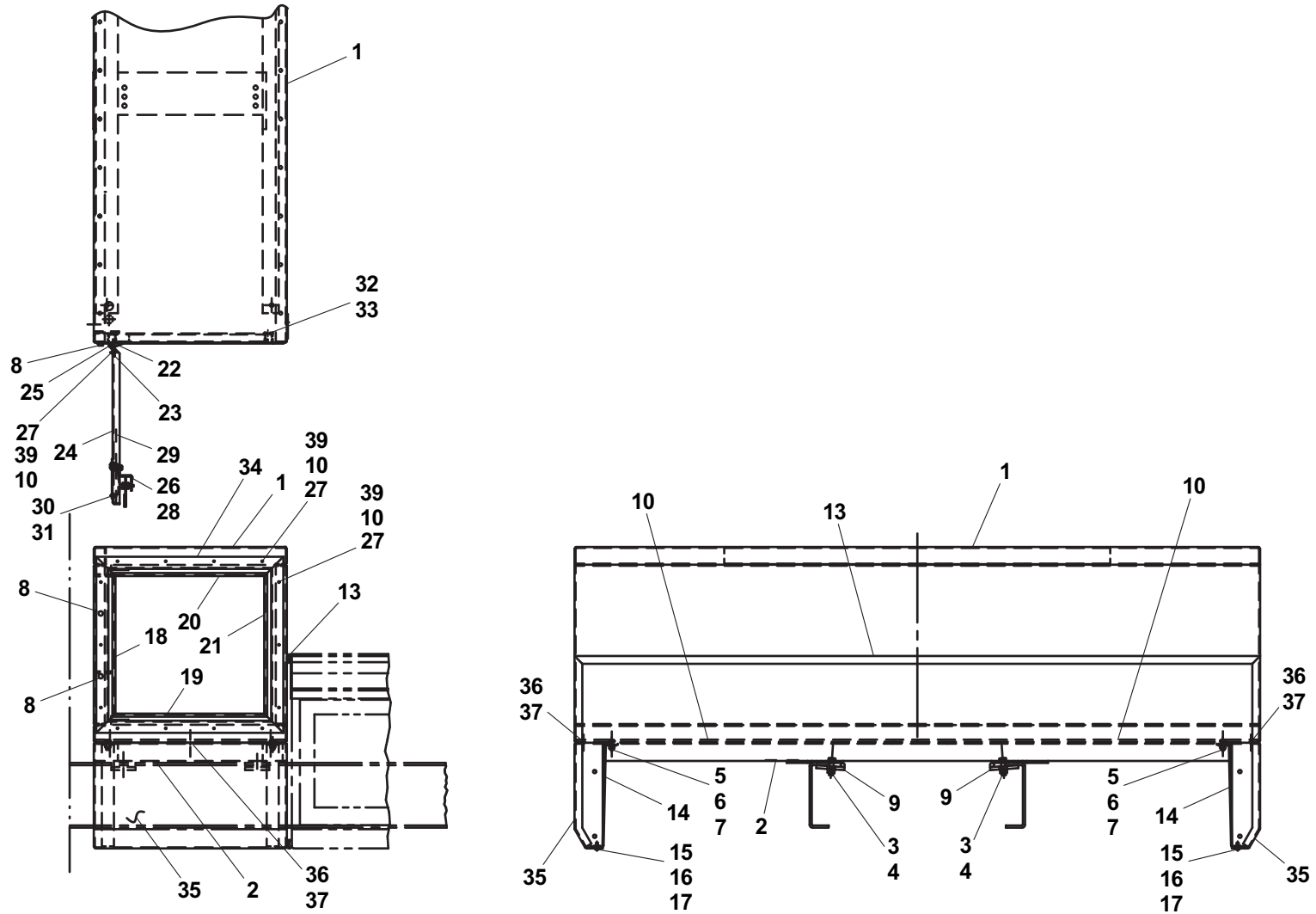

Item #38, Shim not shown

TUNNEL TOOLBOX - 48" ALUMINUM - FOREIGN

ITEM	PART NO.	DESCRIPTION	QTY	ITEM	PART NO.	DESCRIPTION	QTY
1	3899000040	Tunnel Toolbox Weld (48" wide)	1	33	7796000012	Seal	348in
2	3455000019	Frame Weld	1	34	4812000047	Shim	4
3	7115181450	Capscrew, 0.50"-13NC x 1.75"	4	35	7949000056	Washer, 0.50 OD	68
4	7660182301	Locknut, 0.50"-13NC	4	36	7660142601	Locknut, 0.25"-20NC	12
5	7115161050	Capscrew, 0.38"-16NC x 1.25"	6	37	7661000062	Washer, 0.25"-20NC	56
6	7950160161	Flatwasher, 0.38" ID	10				
7	7660162601	Locknut, 0.38"-16NC	10				
8	7189000007	Bumper	8				
9	3274000007	Clamp Weld	4				
10	7114160618	Capscrew, 0.38"-16NC x 1.00"	60				
11	4178000187	Bracket	4				
12	4679000090	Pad	4				
13	7632046140	Moulding	140in				
14	4411000089	Seal Channel - LH	4				
15	4411000071	Seal Channel - Top	4				
16	4411000074	Seal Channel - Bottom	4				
17	4411000090	Seal Channel - RH	4				
18	4706000022	Plate	8				
19	4411000091	Hinge	4				
20	4706001075	Door	4				
21	4763000153	Hinge Rod	4				
22	7585000012	T-Handle Latch	4				
23	7114140618	Capscrew, 0.25"-20NC x 0.75"	68				
24	7796000084	Gasket	4				
25	7796000002	Seal	240in				
26	7114080418	Capscrew, #8-32NC x 0.50"	16				
27	7660082500	Locknut, #8-32NC	16				
28	4706003611	Plate	4				
29	7759000017	Rivet	8				
30	4686000042	Panel	2				
31	7111160650	Capscrew, 0.38"-16NC x 0.75"	10				
32	7413000003	Nutsert, 0.38"-16NC	10				

TUNNEL TOOLBOX - 48" ALUMINUM - FOREIGN

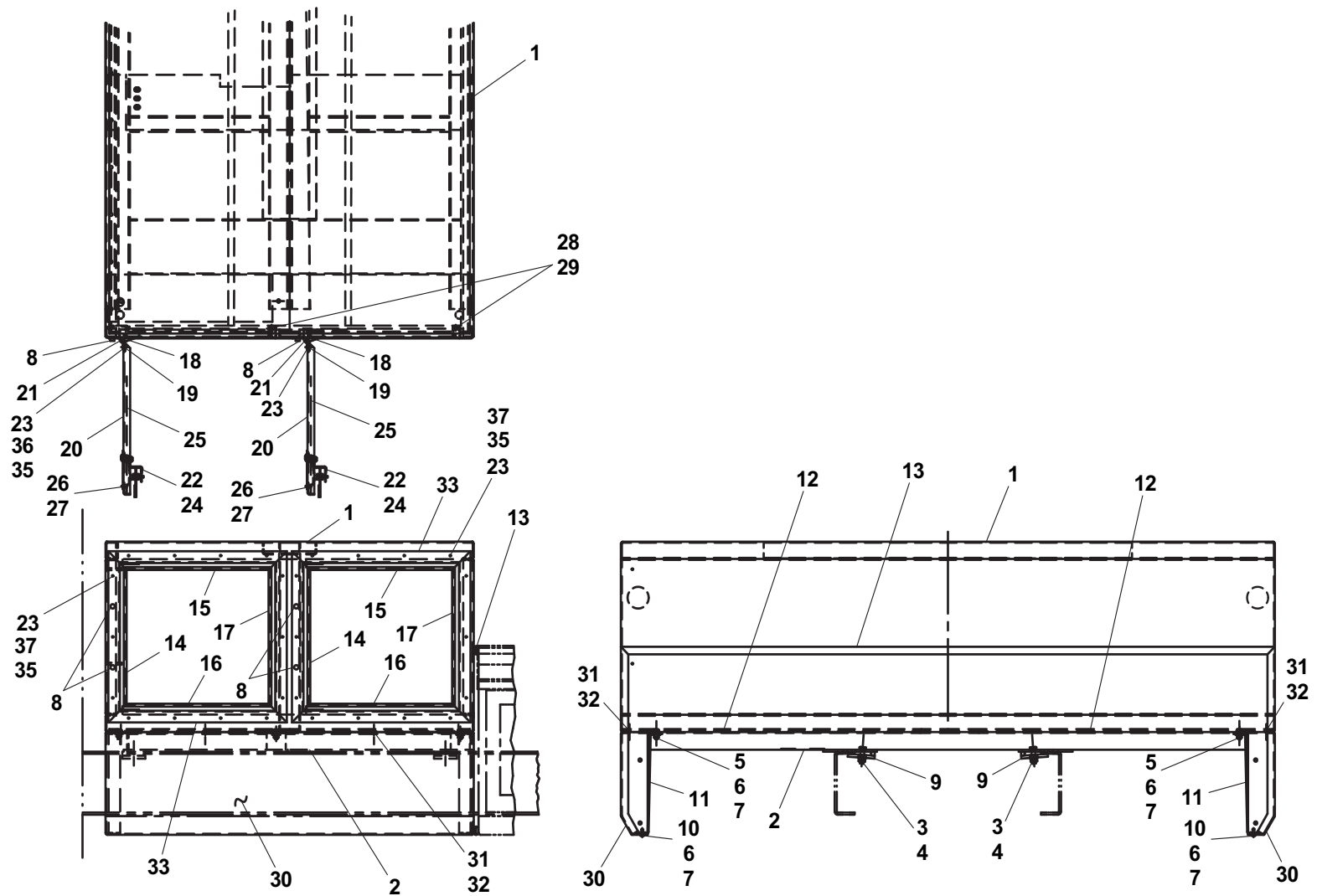

Item #34, Shim not shown

TUNNEL TOOLBOX - 24" ALUMINUM - FORD, IHC & GMC

ITEM	PART NO.	DESCRIPTION	QTY	ITEM	PART NO.	DESCRIPTION	QTY
1	3899000113	Tunnel Toolbox Weld (24" wide)	1	33	7585000012*	T-Handle Latch	2
2	7636000005	Rubber Mount	4	34	7660162301	Locknut, 0.38"-16NC	12
3	7949000013	Head Washer	8	35	7796000084*	Gasket	2
4	4812000108	Shim	4	36	7796000002*	Seal	120in
5	4812000107	Shim	4	37	7114080418*	Capscrew, #8-32NC x 0.50"	8
6	7115182850	Capscrew, 0.50"-13NC x 3.50"	4	38	7660082500*	Locknut, #8-32NC	8
7	7115181864	Capscrew, 0.50"-13NC x 2.25" Carriage	4	39	4706003611*	Plate	2
8	7950180161	Flatwasher, 0.50" ID	4	40	7759000017*	Rivet	4
9	7660182601	Locknut, 0.50"-13NC	9	41	7114140618*	Capscrew, 0.25"-20NC x 0.75"	40
10	3274000007	Clamp Weld	4	42	7949000056*	Nylon Washer, 0.25" ID	40
11	4679000029	Pad	1	43	7661000062*	Locknut, 0.25"-20NC	40
12	4679000030	Pad	1	44	7346000038	Ground Strap	1
13	4679000107	Pad	1	45	4706005869	Plate	4
14	7189000010	Bumper	4	46	7115161250	Capscrew, 0.38"-16NC x 1.50"	12
15	7796000078	Moulding	144in	47	3455000003	Door & Frame Assembly	2
16	7950180252	Flatwasher, 0.50" ID	4				
17	7636000041	Toolbox Frame Weld	1				
18	7114140618	Capscrew, 0.25"-20NC x 0.75"	3				
19	7950140000	Lockwasher, 0.25" ID	3				
20	7950140153	Flatwasher, 0.25" ID	3				
21	7274000105	Clamp	3				
22	7950140500	Lockwasher, 0.25" ID	3				
23	7413000002	Nutsert, 0.25"-20NC	3				
24	7894000042	Tie Strap	4				
25	4411000065*	Seal Channel - LH	2				
26	4411000049*	Seal Channel - Top	2				
27	4411000050*	Seal Channel - Bottom	2				
28	4411000051*	Seal Channel - RH	2				
29	4706000022*	Plate	4				
30	4411000047*	Hinge	2				
31	4706000303*	Door	2				
32	4763000035*	Hinge Rod	2				

* included in Door & Frame Assembly, P/N 3455000003

TUNNEL TOOLBOX - 24" ALUMINUM - FORD, IHC & GMC

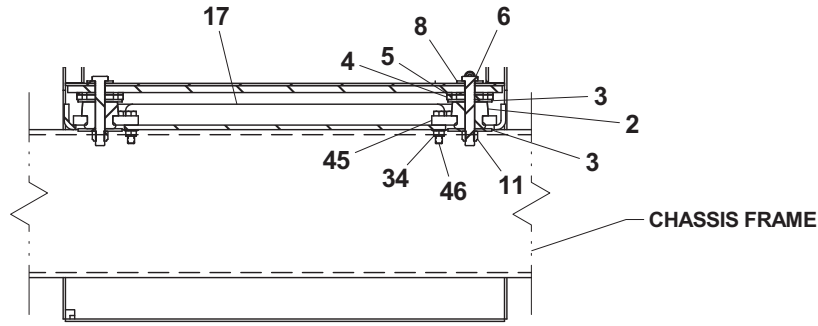

SECTION A-A

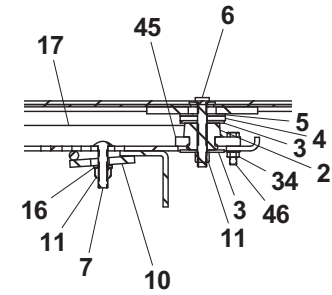

DETAIL B

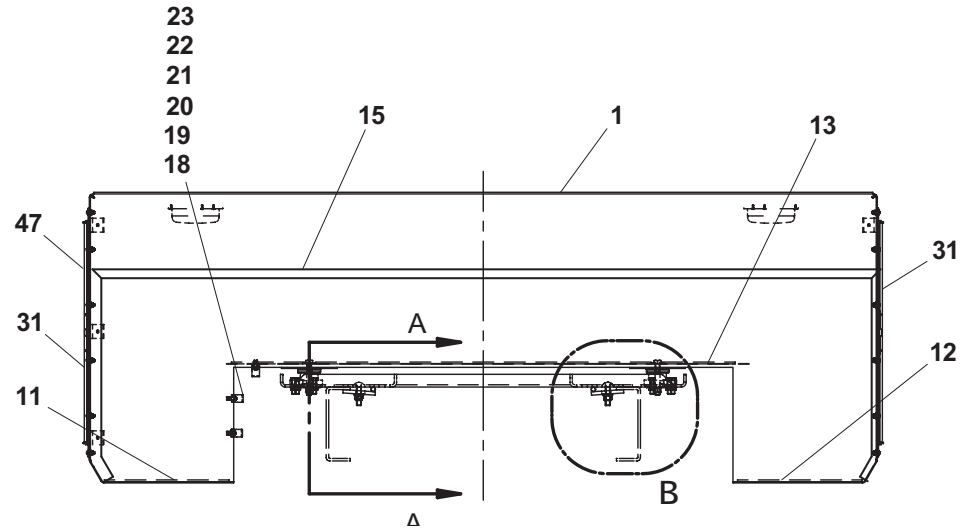
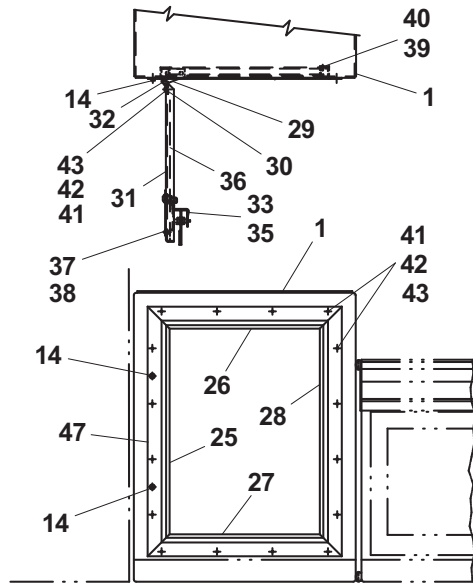

Item #24, Tie Strap, not shown
 Item #44, Ground Strap, not shown

TUNNEL TOOLBOX - 22" & 24" STEEL - FOREIGN

ITEM	PART NO.	DESCRIPTION	QTY
1	3899000079	Tunnel Toolbox Weld (22" wide)	1
	3899000029	Tunnel Toolbox Weld (24" wide)	
2	3455000033	Frame Weld (22" wide)	1
	3455000018	Frame Weld (24" wide)	
3	7115181450	Capscrew, 0.50"-13NC x 1.75"	4
4	7660182301	Locknut, 0.50"-13NC	4
5	7115161010	Capscrew, 0.38"-16NC x 1.25"	6
6	7950160161	Flatwasher, 0.38" ID	4
7	7660162601	Locknut, 0.38"-16NC	4
8	3274000007	Clamp Weld	4
9	4679000204	Pad (22" wide)	2
	4679000090	Pad (24" wide)	
10	3706000176	Door Weld (22" wide)	2
	3706000036	Door Weld (24" wide)	
11	7595000002	Paddle Handle	2
12	7796000031	Gasket	2
13	7114080418	Capscrew, #8-32NC x 0.50"	8
14	7660082500	Locknut, #8-32NC	8
15	3555000006	Hinge Weld	2
16	7118160516	Capscrew, 0.38"-16NC x 0.63"	4
17	7660162301	Locknut, 0.38"-16NC	4
18	4706003126	Plate (22" wide)	2
	4706001130	Plate (24" wide)	
19	7111160650	Capscrew, 0.38"-16NC x 0.75"	6
20	7413000003	Nutsert, 0.38"-16NC	6
21	7632046140	Moulding	140in
22	4178000187	Bracket	4
23	7114140611	Capscrew, 0.25"-20NC x 0.75"	4
24	7950140153	Flatwasher, 0.25" ID	4
25	7660142604	Locknut, 0.25"-20NC	4

TUNNEL TOOLBOX - 22" & 24" STEEL - FOREIGN

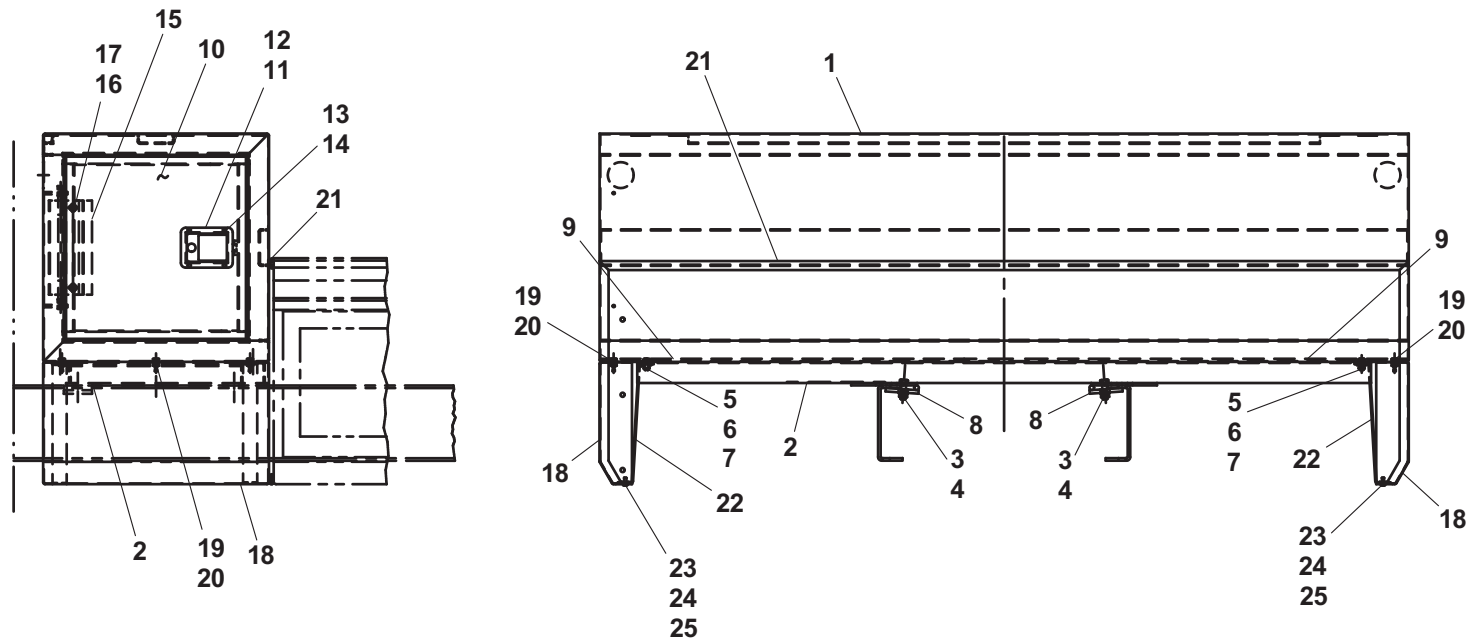

TUNNEL TOOLBOX - 24" STEEL - FORD, IHC & GMC

ITEM	PART NO.	DESCRIPTION	QTY
1	3899000041	Tunnel Toolbox Weld (24" wide)	1
2	7636000005	Rubber Mount	4
3	7949000013	Head Washer	4
4	7949000012	Tail Washer	4
5	7115181450	Capscrew, 0.50"-13NC x 1.75"	4
6	7950180161	Flatwasher, 0.50" ID	8
7	7660182301	Locknut, 0.50"-13NC	9
8	7115182650	Capscrew, 0.50"-13NC x 3.25"	4
9	4017000674	Angle	2
10	4679000106	Pad	1
11	4679000085	Pad	1
12	4679000108	Pad	1
13	7595000002	Paddle Handle	2
14	7796000031	Gasket	2
15	7114080418	Capscrew, #8-32NC x 0.50"	8
16	7660082500	Locknut, #8-32NC	8
17	3706000036	Door Weld	2
18	3555000006	Hinge Weld	2
19	7118160516	Capscrew, 0.38"-16NC x 0.63"	4
20	7660162301	Locknut, 0.38"-16NC	4
21	4706003126	Plate	2
21	7632046140	Moulding	140in
22	7346000038	Ground Strap	1

TUNNEL TOOLBOX - 24" STEEL - FORD, IHC & GMC

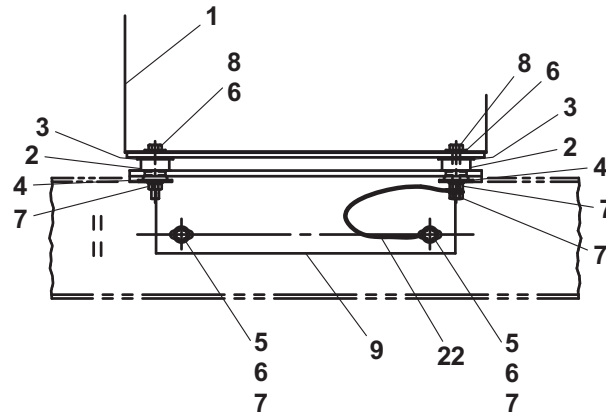

VIEW A - A

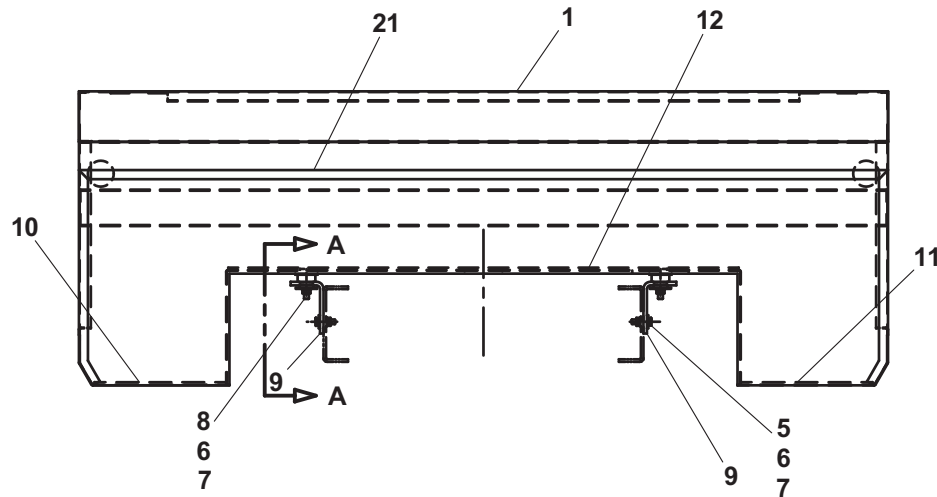
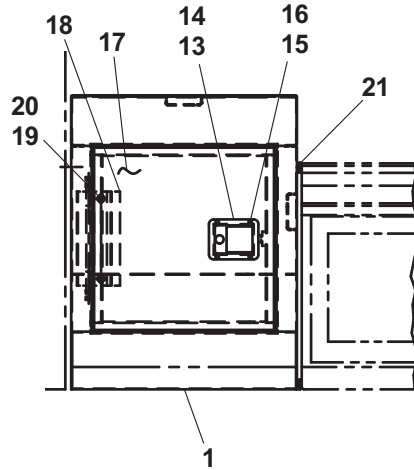

DECK MOUNTED 8,000 LB RECOVERY WINCH

ITEM	PART NO.	DESCRIPTION	QTY
1	3502900010	Winch Mount Weld	1
2	7115241250	Capscrew, 0.88"-9NC x 1.50"	4
3	7950240161	Lockwasher, 0.88" ID	4
4	3512900006	Sheave Support Weld	1
5	3510900068	Cable Guide Weld	1
6	3691000002	Pin Weld	1
7	7626000014	Orbit Motor	1
8	7970000147	Winch 8,000 lb Worm Gear	1
9	7754000005	Retaining Ring	1
10	7111181050	Capscrew, 0.50"-13NC x 1.50"	2
11	7950180400	Lockwasher, 0.50" ID	2
12	7754000006	Retaining Ring	1
13	7809000001	Sheave	1
14	7440030000	Grease Fitting	2
15	4314000004	Cover Plate	1
16	7114140823	Capscrew, 0.25"-20NC x 1.00"	6
17	7661000006	Well Nut, 0.25"-20 NC	6
18	7950160161	Flatwasher, 0.38" ID	8
19	7950160000	Lockwasher, 0.38" ID	8
20	7115160850	Capscrew, 0.38"-16NC x 1.00"	8
21	4209000019	Bushing	2
22	7445081043	Adapter	2
23	4567332075	Hose Assembly	2
24	7443000023	Elbow	2
25	7445080843	Adapter	2
26	7701000068	Plug	1
27	7935000174	Relief Valve	1

DECK MOUNTED 8,000 LB RECOVERY WINCH

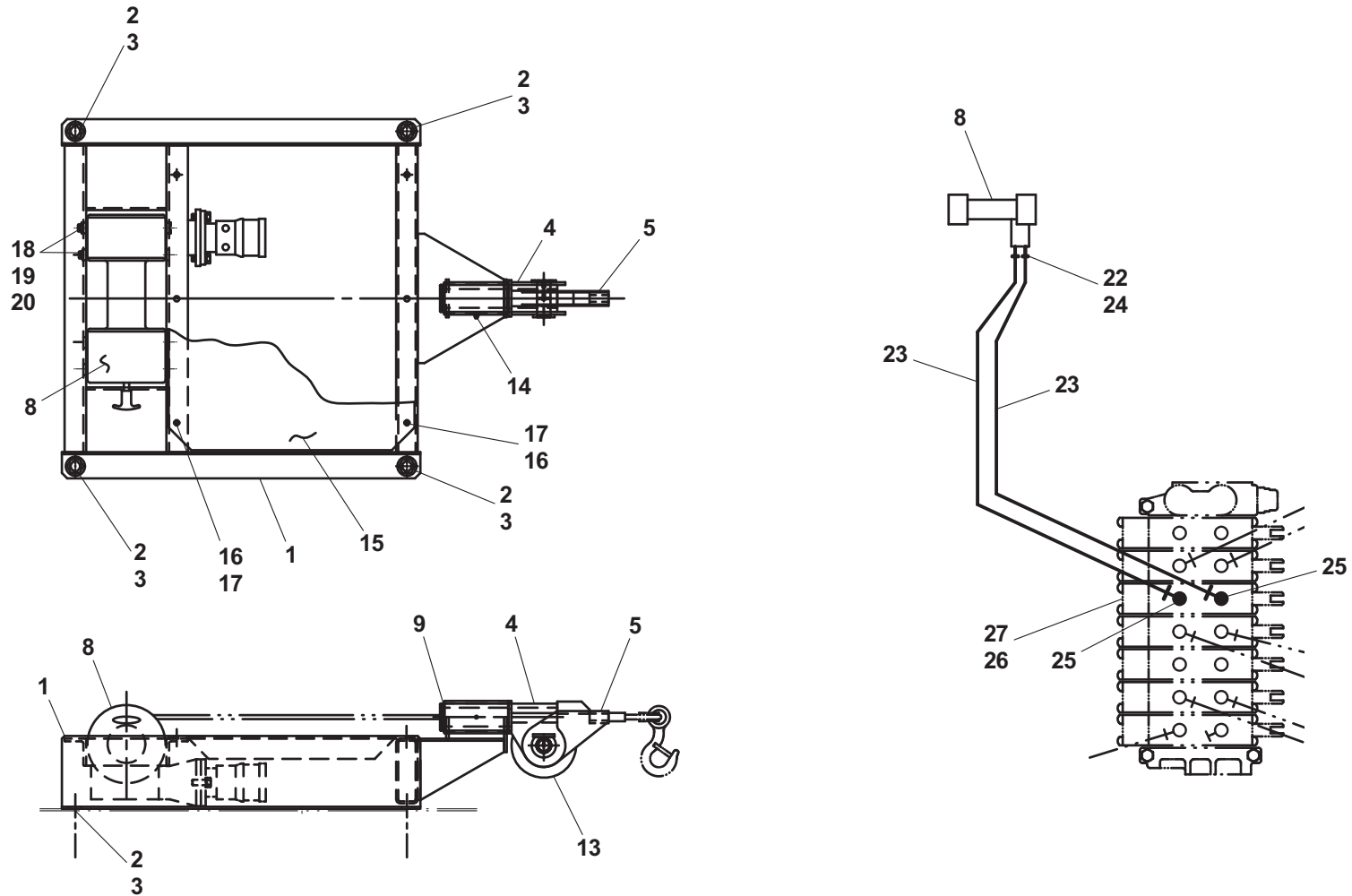

DECK MOUNTED RECOVERY WINCH CABLE TENSIONER

ITEM	PART NO.	DESCRIPTION	QTY
1	3500900015	Tensioner Weld	1
2	7115181050	Capscrew, 0.50"-13NC x 1.25"	2
3	7660182600	Locknut, 0.50"-13NC	2
4	7843000004	Compression Spring	1
5	7950180161	Flatwasher, 0.50" ID	2
6	7660182600	Locknut, 0.50"-13NC	1

DECK MOUNTED RECOVERY WINCH CABLE TENSIONER

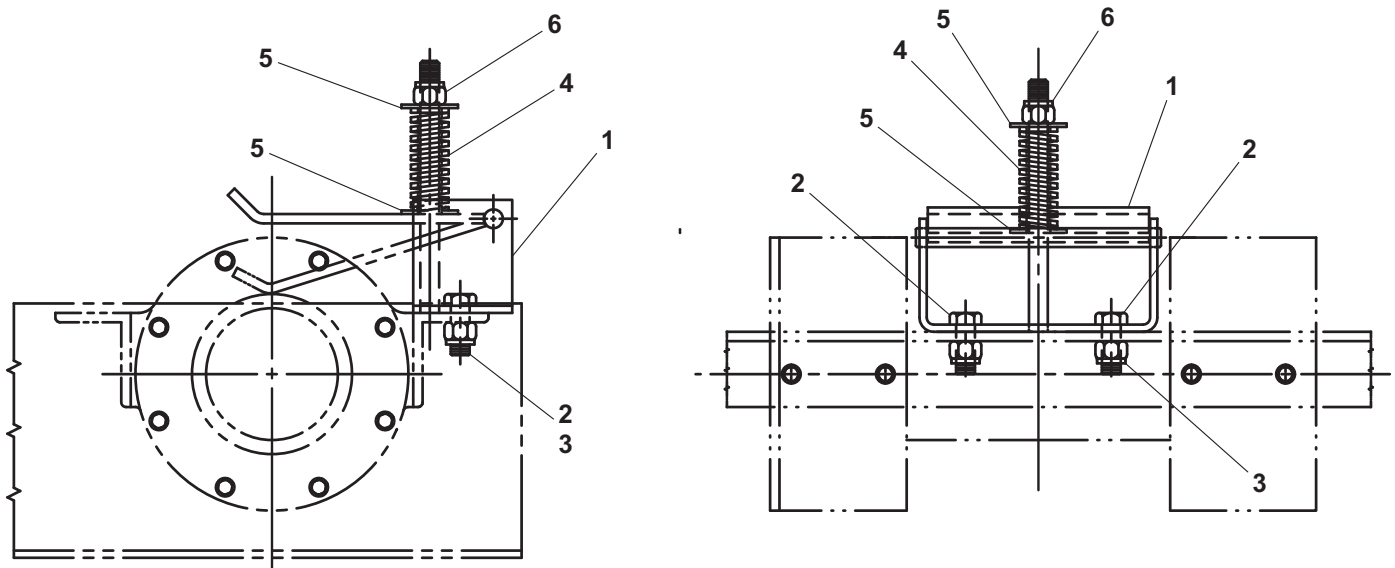

4 TON WRECKER BOOM - SINGLE 8,000 LB WINCH

ITEM	PART NO.	DESCRIPTION	QTY	ITEM	PART NO.	DESCRIPTION	QTY
1	3073000005	Frame Weld	1	33	7912000029	Tube Assembly	1
2	7115241650	Capscrew, 0.88"-9NC x 2.00"	4	34	7445060645	Elbow	2
3	7950240162	Flatwasher, 0.88" ID	4	35	7445060647	Tee	1
4	3170000067	Base Boom Weld	1	36	7912000028	Tube Assembly	1
5	3170000066	Fly Boom Weld	1	37	4691000120	Pin	1
6	3320000044	Cylinder Assembly	1	38	7754000019	Retaining Ring	3
7	3320000045	Cylinder Assembly	1	39	7445060646	Elbow	2
8	3510900068	Cable Guide Weld	1	40	7701000030	Plug	2
9	3512900006	Sheave Support Weld	1	41	4706001255	Plate	1
10	7754000005	Retaining Ring	1	42	7626000014	Orbit Motor	1
11	3691000002	Pin Weld	1	43	7115161250	Capscrew, 0.50"-13NC x 1.50"	2
12	7754000006	Retaining Ring	1	44	7950180400	Lockwasher, 0.50" ID	2
13	4209000019	Bushing	2	45	7445080843	Adapter	2
14	7440030000	Grease Fitting	7	46	7445060843	Adapter	4
15	7809000001	Sheave	1	47	4567322064	Hose Assembly	2
16	3691000113	Pin Weld	1	48	7445081043	Adapter	2
17	3691000103	Pin Weld	1	49	4567122055	Hose Assembly	2
18	3691000104	Pin Weld	1	50	4567332075	Hose Assembly	2
19	3691000105	Pin Weld	1	51	7443000137	Elbow	1
20	7970000104	Winch 8,000 lb Worm Gear	1	52	7443000023	Elbow	2
21	4314000024	Cover Plate	1	53	7445060643	Adapter	2
22	4679000088	Slide Pad	1	54	7445060672	Elbow	1
23	4679000089	Slide Pad	1	55	7701000068	Plug	1
24	7660152601	Locknut, 0.31"-18NC	2	56	7935000174	Relief Valve	1
25	7950150161	Flatwasher, 0.31" ID	2	57	7253000002	Grease Fitting	7
26	7115160850	Capscrew, 0.38"-16NC x 1.00"	8				
27	7950160000	Lockwasher, 0.38" ID	8				
28	7950160162	Flatwasher, 0.38" ID	19				
29	7115161050	Capscrew, 0.38"-16NC x 1.25"	4				
30	7660162601	Locknut, 0.38"-16NC	7				
31	7111151650	Capscrew, 0.31"-18NC x 2.00"	2				
32	7935000001	Counterbalance Valve	1				

4 TON WRECKER BOOM - SINGLE 8,000 LB WINCH

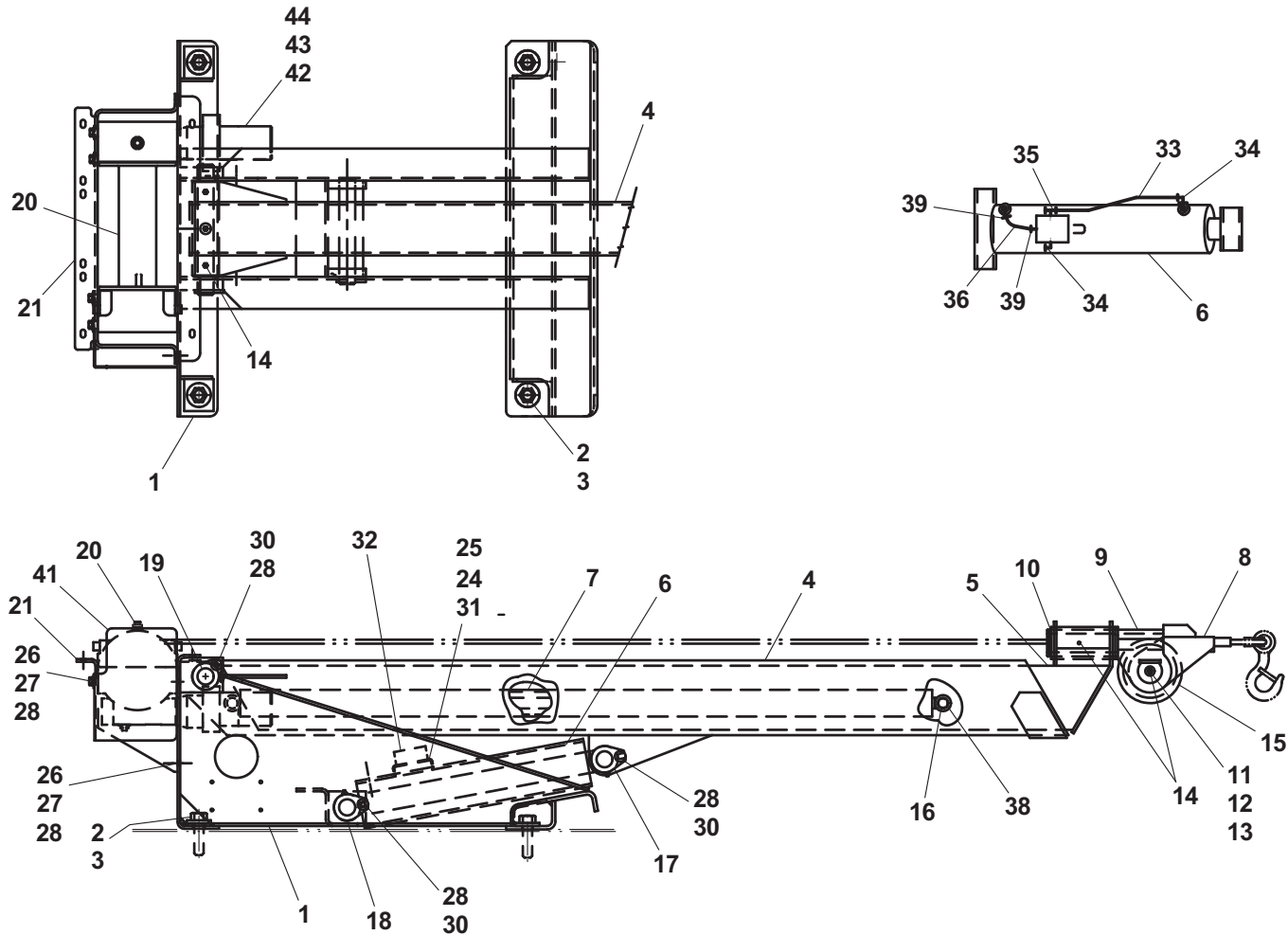

4 TON WRECKER BOOM - SINGLE 8,000 LB WINCH

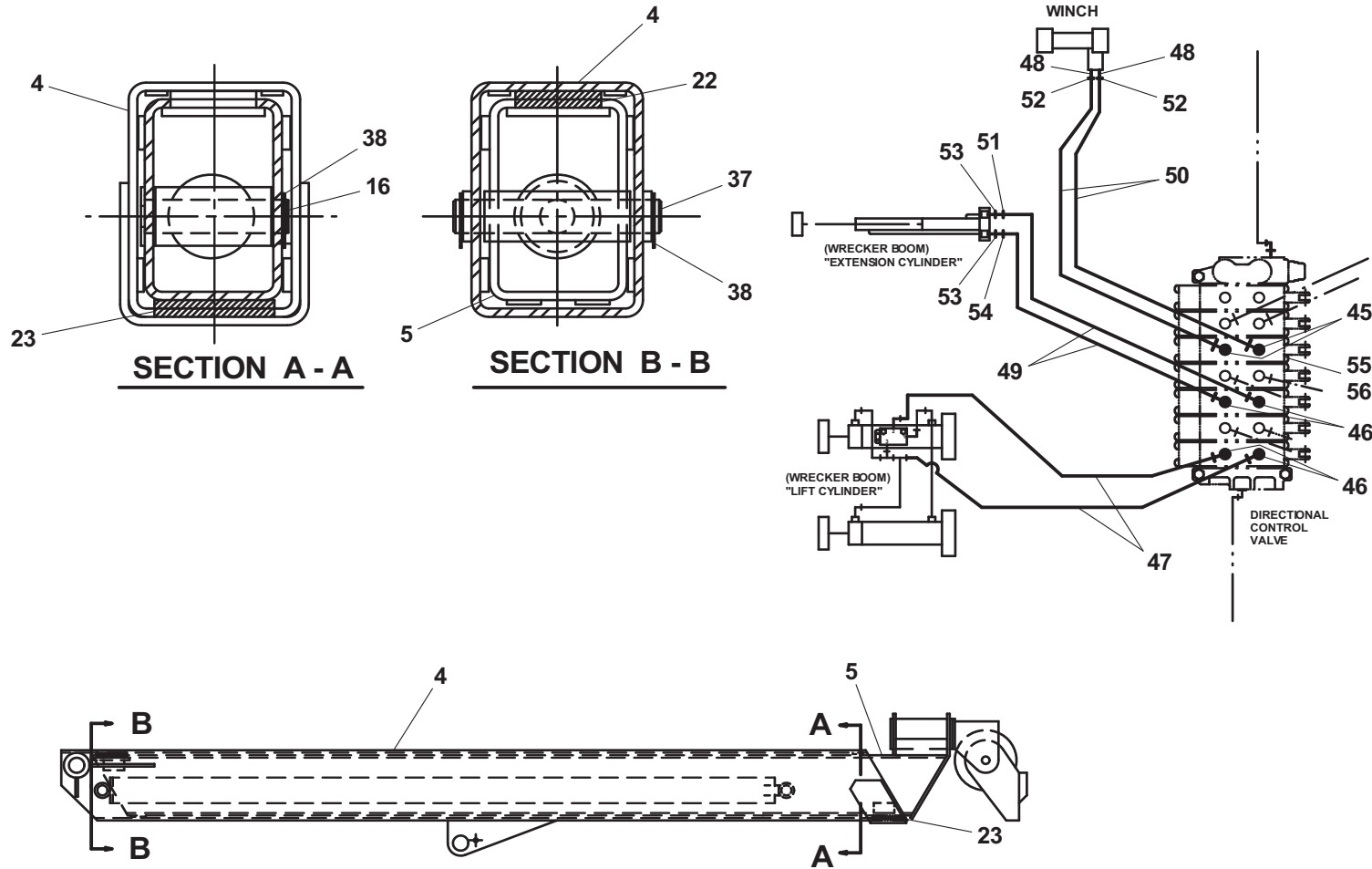

THIS PAGE INTENTIONALLY LEFT BLANK

8 TON WRECKER BOOM - SINGLE 8,000 LB WINCH

ITEM	PART NO.	DESCRIPTION	QTY	ITEM	PART NO.	DESCRIPTION	QTY
1	3511100079	Frame Weld	1	35	7660162601	Locknut, 0.38"-16NC	4
2	7115245650	Capscrew, 0.88"-9NC x 7.00"	4	36	7115151050	Capscrew, 0.31"-18NC x 1.25"	6
3	7950240161	Flatwasher, 0.88" ID	4	37	7115181050	Capscrew, 0.50"-13NC x 1.25"	2
4	3510100062	Base Boom Weld	1	38	7950180400	Lockwasher, 0.50" ID	2
5	3510100060	Fly Boom Weld	1	39	7118140418	Capscrew, 0.25"-20NC x 0.50"	2
6	3510100058	Boom Nose Weld	1	40	7950160000	Lockwasher, 0.38" ID	8
7	3512900006	Sheave Support Weld	1	41	7115160850	Capscrew, 0.38"-16NC x 1.00"	8
8	3510900068	Cable Guide Weld	1	42	7660152601	Locknut, 0.31"-18NC	8
9	3510100050	Singe Winch Mount Weld	1	43	4567222022	Hose Assembly	1
10	3691000002	Pin Weld	1	44	7912000001	Tube Assembly	1
11	3320000011	Cylinder Assembly	1	45	4570000008	Hose Assembly	1
12	3320000012	Cylinder Assembly	1	46	7445060645	Elbow	4
13	3320000007	Cylinder Assembly	1	47	7445060648	Tee	1
14	3691000075	Pin Weld	4	48	7445060646	Elbow	1
15	3691000076	Pin Weld	2	49	7445060647	Tee	1
16	4706000067	Plate	1	50	7443000030	Tee	1
17	4691000027	Pin	1	51	7912000002	Tube Assembly	1
18	4691000179	Pin	1	52	7935000001	Counterbalance Valve	1
19	4679000005	Wear Pad	1	53	7950150161	Flatwasher, 0.31 ID	8
20	4679000004	Wear Pad	1	54	7111151650	Capscrew, 0.31"-18NC x 2.00"	2
21	4706000160	Plate	1	55	4706001255	Plate	1
22	7970000103	Winch - 8,000 lb Worm Gear	1	56	7950140161	Flatwasher, 0.25" ID	2
23	7626000014	Orbit Motor	1	57	7445080843	Adapter	2
24	7754000006	Retaining Ring	5	58	7445060843	Adapter	4
25	7809000001	Sheave	1	59	4567322064	Hose Assembly	2
26	7754000005	Retaining Ring	1	60	7445081043	Adapter	2
27	7440030000	Grease Fitting	8	61	4567122055	Hose Assembly	2
28	7115180850	Capscrew, 0.50"-13NC x 1.00"	2	62	4567332075	Hose Assembly	2
29	7115181250	Capscrew, 0.50"-13NC x 1.50"	4	63	7443000137	Elbow	1
30	7660182600	Locknut, 0.50"-13NC	4	64	7443000023	Elbow	2
31	4209000019	Bushing	2	65	7445060643	Adapter	2
32	7950180000	Lockwasher, 0.50" ID	2	66	7445060672	Elbow	1
33	7115161050	Capscrew, 0.38"-16NC x 1.25"	4	67	7701000068	Plug	1
34	7950160162	Flatwasher, 0.38" ID	16	68	7935000174	Relief Valve	1
				69	7253000002	Grease Fitting	8

8 TON WRECKER BOOM - SINGLE 8,000 LB WINCH

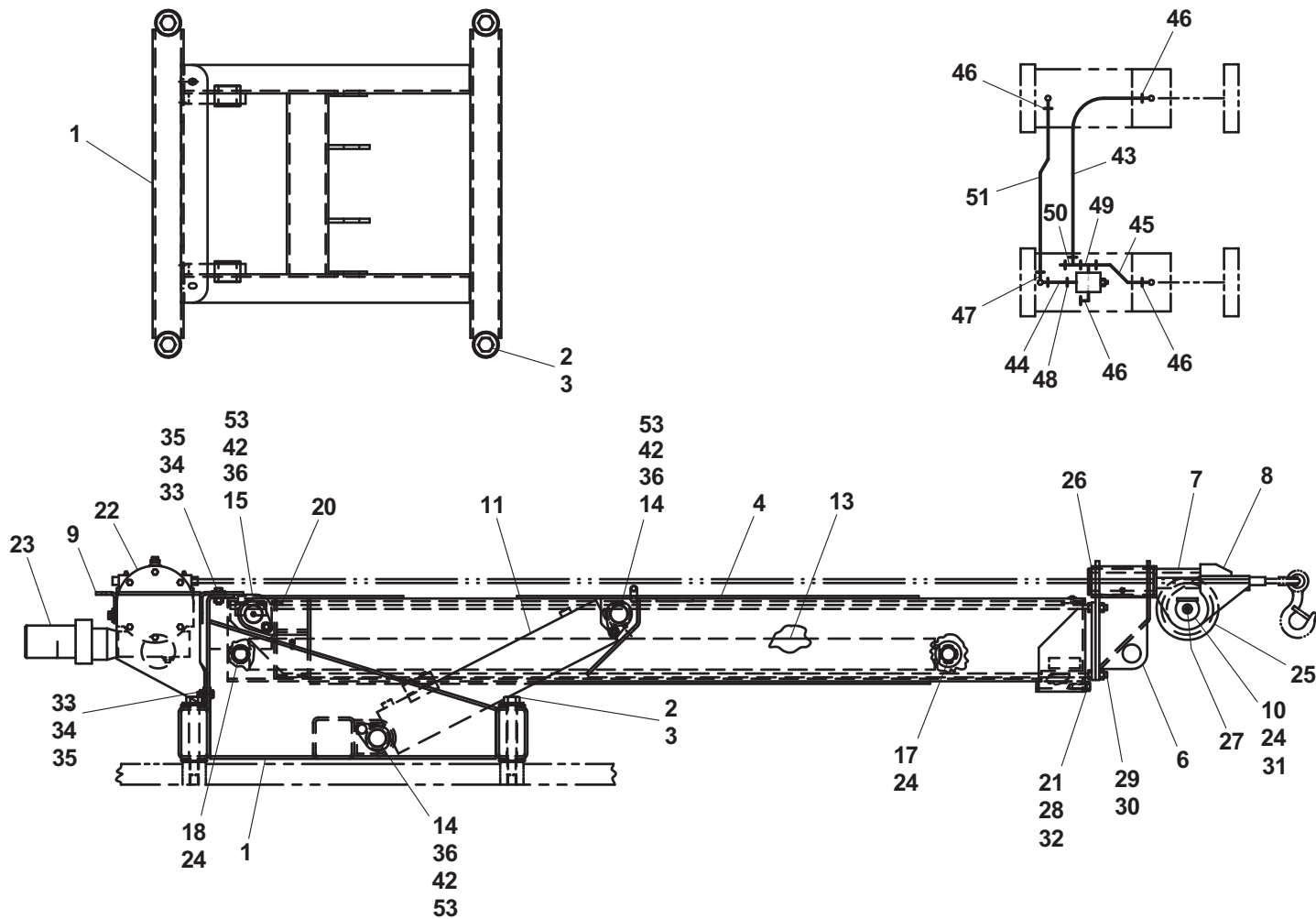

8 TON WRECKER BOOM - SINGLE 8,000 LB WINCH

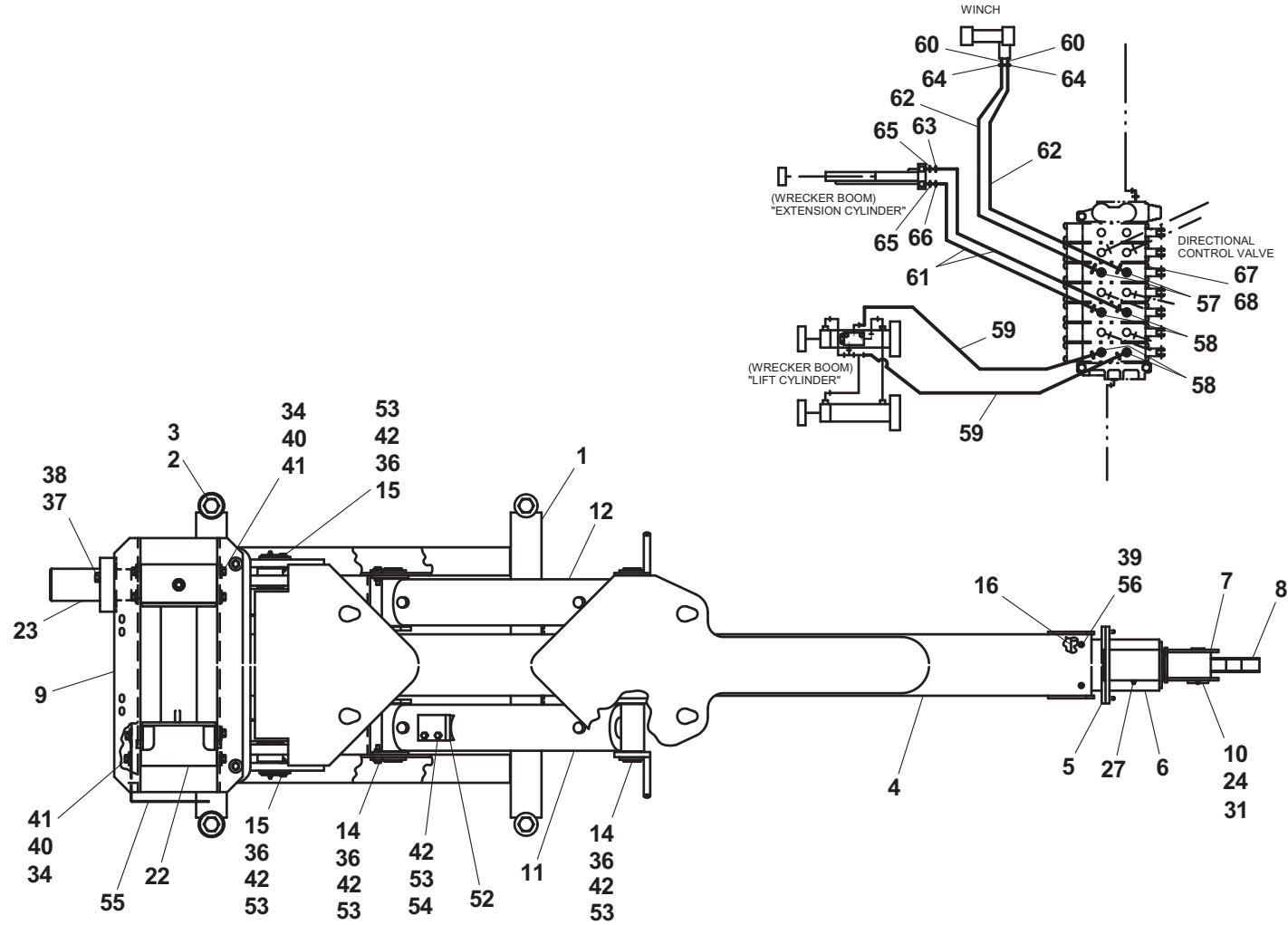

THIS PAGE INTENTIONALLY LEFT BLANK

8 TON WRECKER BOOM - DUAL 8,000 LB WINCH

ITEM	PART NO.	DESCRIPTION	QTY	ITEM	PART NO.	DESCRIPTION	QTY
1	3511100079	Frame Weld	1	35	7950160162	Flatwasher, 0.38" ID	28
2	7115245650	Capscrew, 0.88"-9NC x 7.00"	4	36	7660162601	Locknut, 0.38"-16NC	6
3	7950240161	Flatwasher, 0.88" ID	4	37	7115151050	Capscrew, 0.31"-18NC x 1.25"	6
4	3510100062	Base Boom Weld	1	38	7115181050	Capscrew, 0.50"-13NC x 1.25"	4
5	3510100060	Fly Boom Weld	1	39	7950180400	Lockwasher, 0.50" ID	4
6	3502100024	Boom Nose Weld	1	40	7118140418	Capscrew, 0.25"-20NC x 0.50"	2
7	3502900023	Sheave Support Weld	2	41	7950160000	Lockwasher, 0.38" ID	16
8	3249000002	Cable Guide Weld	2	42	7115160850	Capscrew, 0.38"-16NC x 1.00"	16
9	3510100051	Dual Winch Mount Weld	1	43	7660152601	Locknut, 0.31"-18NC	8
10	3691000134	Pin Weld	2	44	4567222022	Hose Assembly	1
11	3320000011	Cylinder Assembly	1	45	7912000001	Tube Assembly	1
12	3320000012	Cylinder Assembly	1	46	4570000008	Hose Assembly	1
13	3320000007	Cylinder Assembly	1	47	7445060645	Elbow	4
14	3691000075	Pin Weld	4	48	7445060648	Tee	1
15	3691000076	Pin Weld	2	49	7445060646	Elbow	1
16	4706000067	Plate	1	50	7445060647	Tee	1
17	4691000027	Pin	1	51	7443000030	Tee	1
18	4691000179	Pin	1	52	7912000002	Tube Assembly	1
19	4679000005	Wear Pad	1	53	7935000001	Counterbalance Valve	1
20	4679000004	Wear Pad	1	54	7950150161	Flatwasher, 0.31 ID	8
21	4706000160	Plate	1	55	7111151650	Capscrew, 0.31"-18NC x 2.00"	2
22	7970000103	Winch - 8,000 lb Worm Gear - LH	1	56	4706001255	Plate	1
23	7970000104	Winch - 8,000 lb Worm Gear - RH	1	57	7950140161	Flatwasher, 0.25" ID	2
24	7626000014	Orbit Motor	2	58	7445080843	Adapter	4
25	7754000006	Retaining Ring	6	59	7445060843	Adapter	4
26	7809000001	Sheave	2	60	4567322064	Hose Assembly	2
27	7754000018	Retaining Ring	2	61	7445081043	Adapter	4
28	7440030000	Grease Fitting	10	62	4567122055	Hose Assembly	2
29	7115180850	Capscrew, 0.50"-13NC x 1.00"	2	63	4567332075	Hose Assembly	4
30	7115181450	Capscrew, 0.50"-13NC x 1.50"	4	64	7443000137	Elbow	1
31	7660182600	Locknut, 0.50"-13NC	4	65	7443000023	Elbow	4
32		Not Required		66	7445060643	Adapter	2
33	7950180000	Lockwasher, 0.50" ID	2	67	7445060672	Elbow	1
34	7115161050	Capscrew, 0.38"-16NC x 1.25"	6	68	7935000174	Relief Valve	2
				69	7253000002	Grease Fitting	10

8 TON WRECKER BOOM - DUAL 8,000 LB WINCH

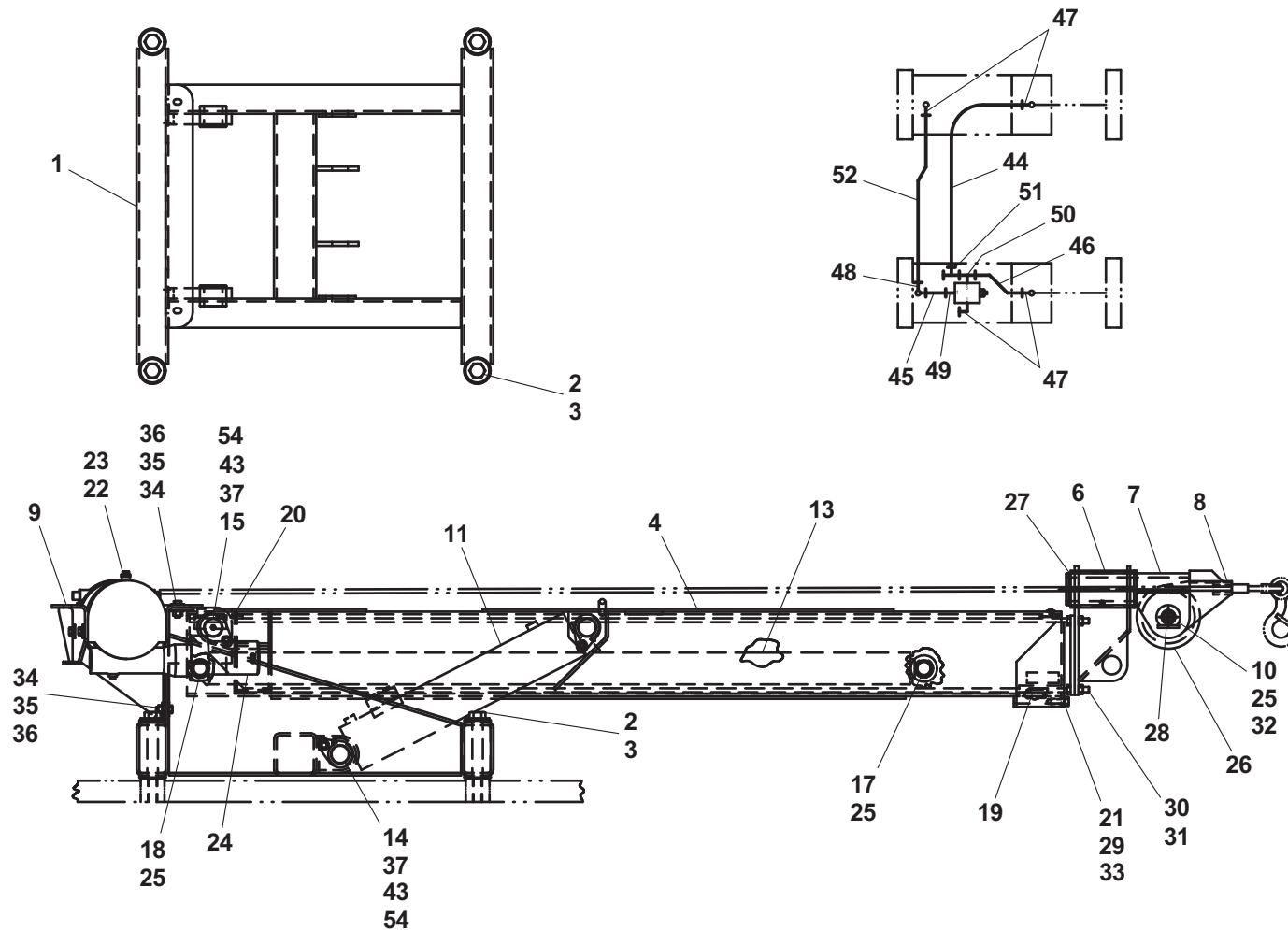

8 TON WRECKER BOOM - DUAL 8,000 LB WINCH

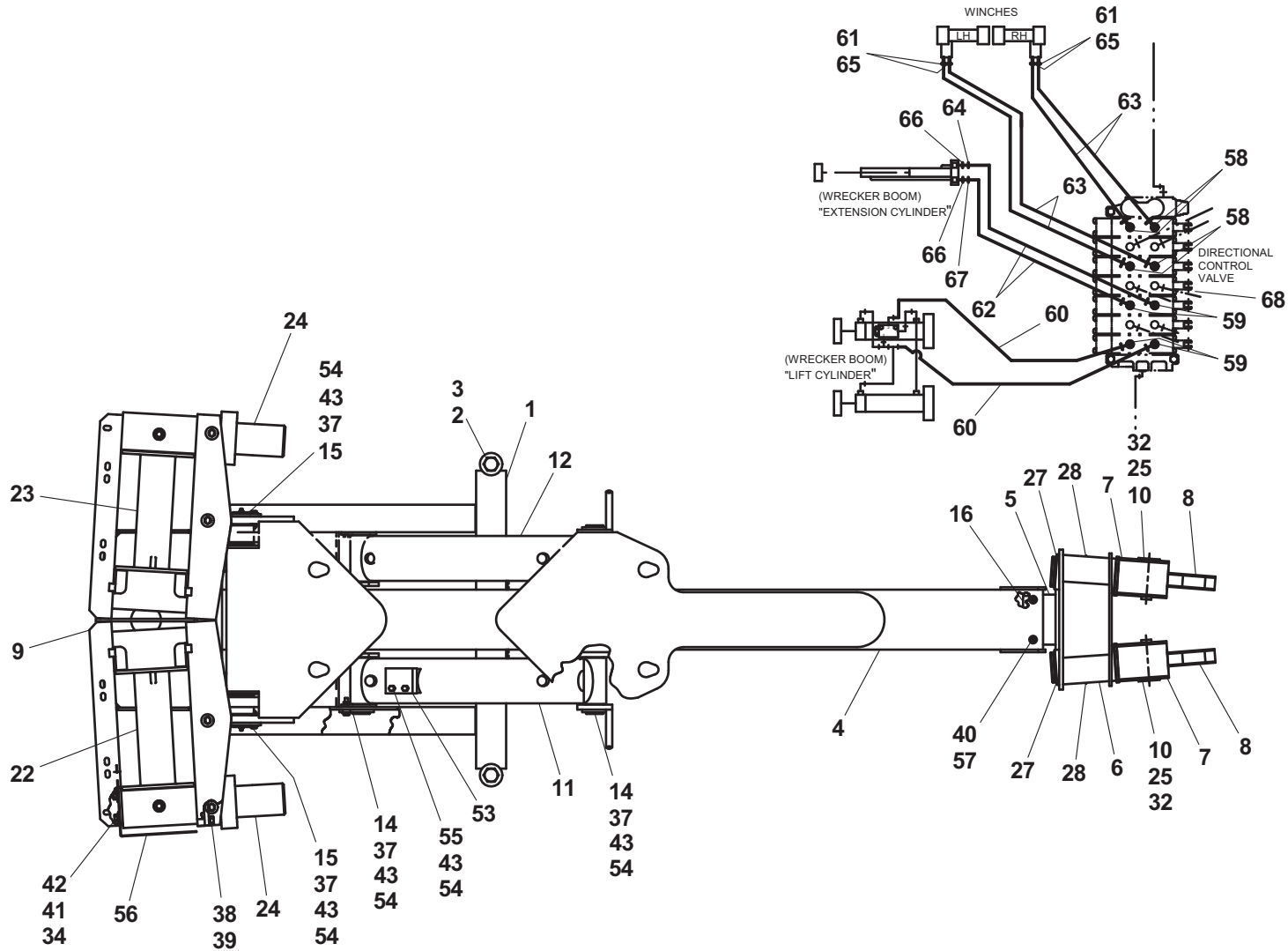

THIS PAGE INTENTIONALLY LEFT BLANK

12 TON WRECKER BOOM - SINGLE 10,000 LB WINCH

ITEM	PART NO.	DESCRIPTION	QTY	ITEM	PART NO.	DESCRIPTION	QTY
1	3512100071	Frame Weld	1	35	7660172601	Locknut, 0.44"-14NC	4
2	7115245650	Capscrew, 0.88"-9NC x 7.00"	4	36	7118151250	Capscrew, 0.31"-18NC x 1.50"	6
3	7950240161	Flatwasher, 0.88" ID	4	37	7115181250	Capscrew, 0.50"-13NC x 1.50"	2
4	3512100004	Base Boom Weld	1	38	7950180400	Lockwasher, 0.50" ID	2
5	3512100005	Fly Boom Weld	1	39	7118140418	Capscrew, 0.25"-20NC x 0.50"	2
6	3510100058	Boom Nose Weld	1	40	7950170000	Lockwasher, 0.44" ID	8
7	3512900006	Sheave Support Weld	1	41	7115170850	Capscrew, 0.44"-14NC x 1.00"	8
8	3510900068	Cable Guide Weld	1	42	7660152601	Locknut, 0.31"-18NC	8
9	3512100040	Singe Winch Mount Weld	1	43	4567222022	Hose Assembly	1
10	3691000002	Pin Weld	1	44	7912000001	Tube Assembly	1
11	3320000011	Cylinder Assembly	1	45	4570000008	Hose Assembly	1
12	3320000012	Cylinder Assembly	1	46	7445060645	Elbow	4
13	3320000007	Cylinder Assembly	1	47	7445060648	Tee	1
14	3691000075	Pin Weld	4	48	7445060646	Elbow	1
15	3691000081	Pin Weld	2	49	7445060647	Tee	1
16	4706000067	Plate	1	50	7443000030	Tee	1
17	4691000133	Pin	1	51	7912000002	Tube Assembly	1
18	4691000179	Pin	1	52	7935000001	Counterbalance Valve	1
19	4679000005	Wear Pad	1	53	7950150161	Flatwasher, 0.31 ID	8
20	4679000004	Wear Pad	1	54	7111151650	Capscrew, 0.31"-18NC x 2.00"	2
21	4706000160	Plate	1	55	4706001255	Plate	1
22	7970000020	Winch - 10,000 lb Worm Gear	1	56	7950140161	Flatwasher, 0.25" ID	2
23	7626000013	Orbit Motor	1	57	7445080843	Adapter	2
24	7754000006	Retaining Ring	5	58	7445060843	Adapter	4
25	7809000001	Sheave	1	59	4567322064	Hose Assembly	2
26	7754000005	Retaining Ring	1	60	7445081043	Adapter	2
27	7440030000	Grease Fitting	8	61	4567122055	Hose Assembly	2
28	7115180850	Capscrew, 0.50"-13NC x 1.00"	2	62	4567332075	Hose Assembly	2
29	7115181250	Capscrew, 0.50"-13NC x 1.50"	4	63	7443000137	Elbow	1
30	7660182600	Locknut, 0.50"-13NC	4	64	7443000023	Elbow	2
31	4209000019	Bushing	2	65	7445060643	Adapter	2
32	7950180000	Lockwasher, 0.50" ID	2	66	7445060672	Elbow	1
33	7118171250	Capscrew, 0.44"-14NC x 1.50"	4	67	7701000068	Plug	2
34	7950160162	Flatwasher, 0.38" ID	16	68	7253000002	Grease Fitting	8

12 TON WRECKER BOOM - SINGLE 10,000 LB WINCH

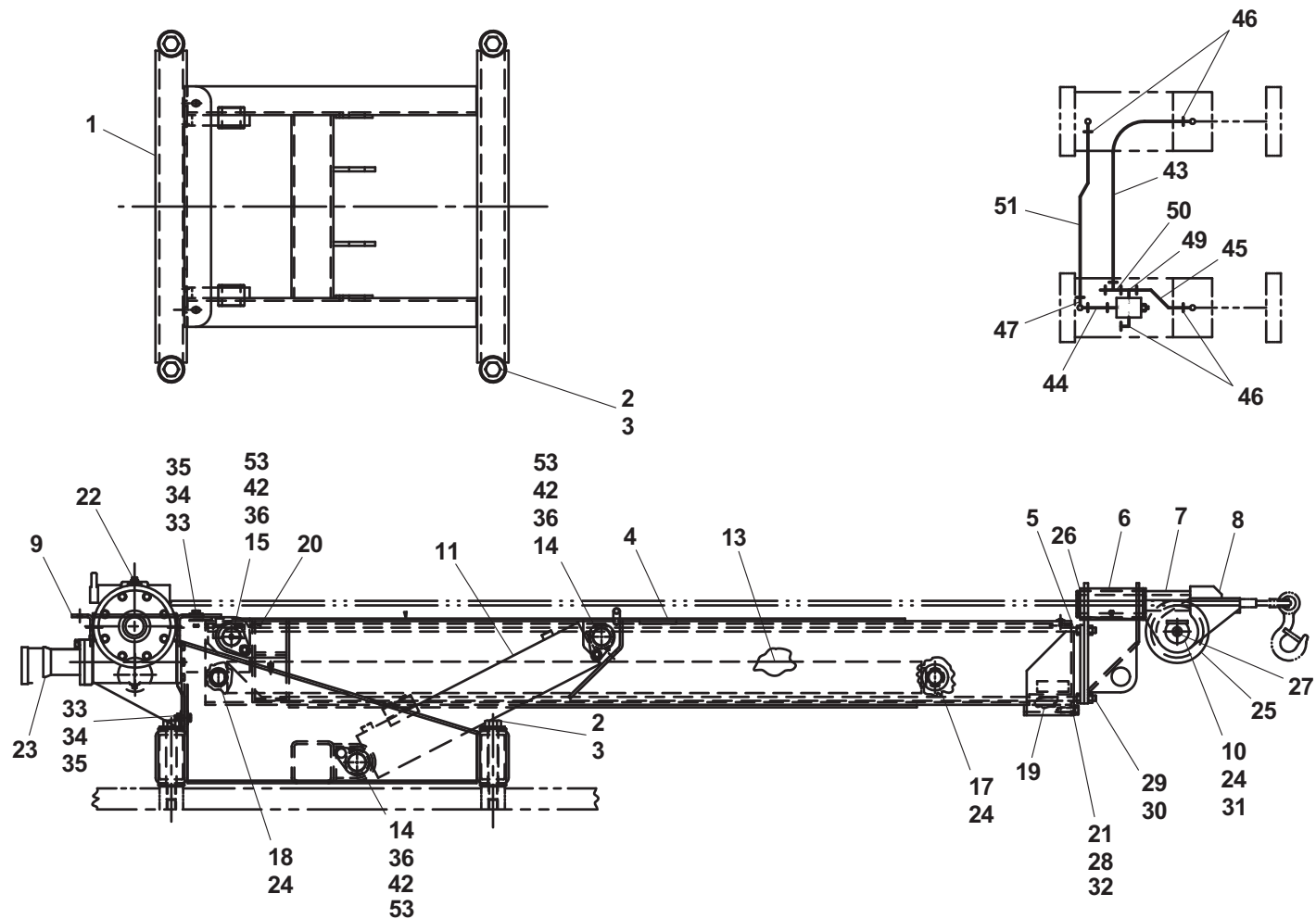

12 TON WRECKER BOOM - SINGLE 10,000 LB WINCH

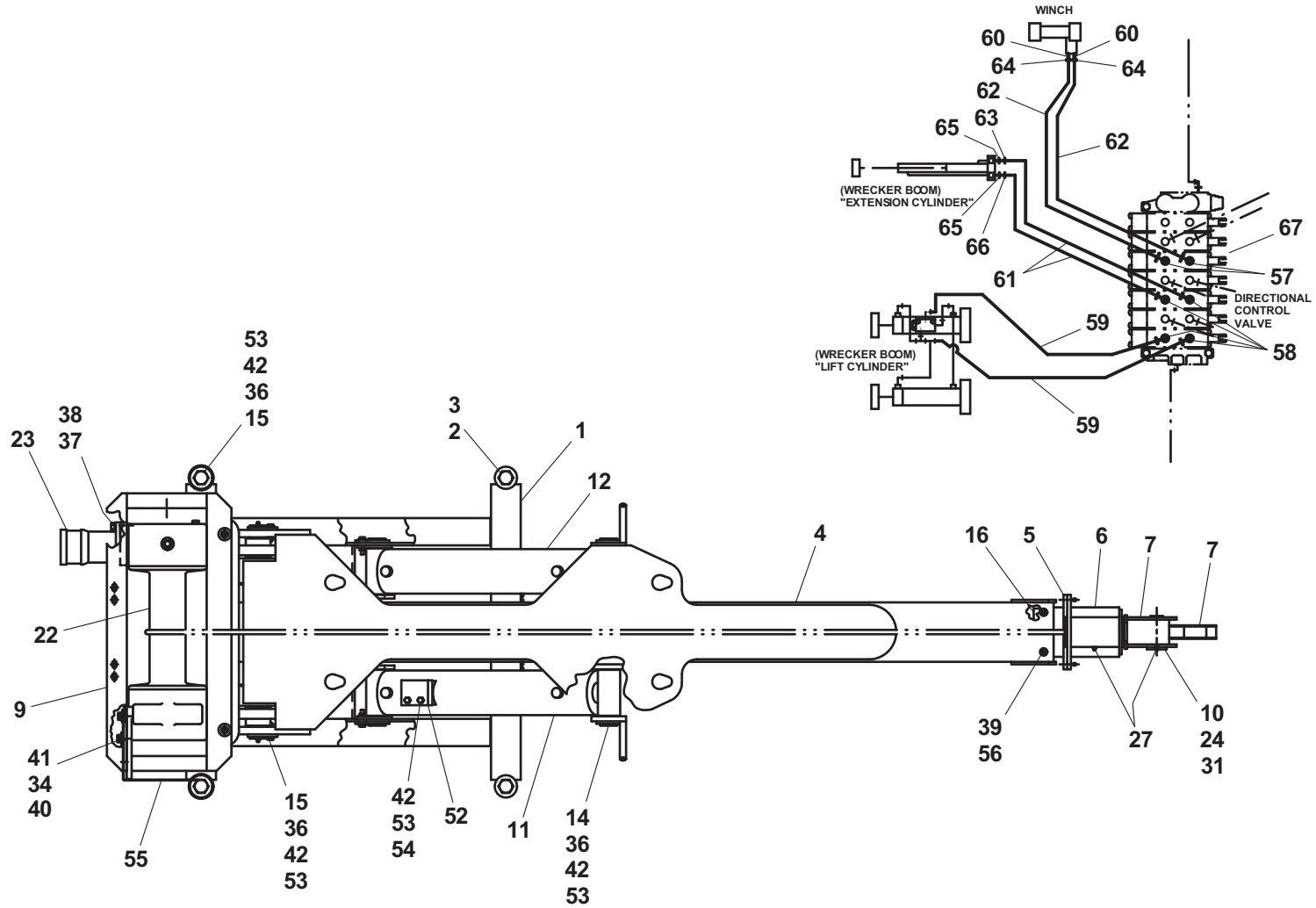

THIS PAGE INTENTIONALLY LEFT BLANK

12 TON WRECKER BOOM - DUAL 10,000 LB WINCH

ITEM	PART NO.	DESCRIPTION	QTY	ITEM	PART NO.	DESCRIPTION	QTY
1	3512100071	Frame Weld	1	35	7950160162	Flatwasher, 0.38" ID	28
2	7115245650	Capscrew, 0.88"-9NC x 7.00"	4	36	7660172601	Locknut, 0.44"-14NC	6
3	7950240161	Flatwasher, 0.88" ID	4	37	7115151250	Capscrew, 0.31"-18NC x 1.50"	6
4	3512100004	Base Boom Weld	1	38	7115181050	Capscrew, 0.50"-13NC x 1.25"	4
5	3512100005	Fly Boom Weld	1	39	7950180400	Lockwasher, 0.50" ID	4
6	3502100024	Boom Nose Weld	1	40	7118140418	Capscrew, 0.25"-20NC x 0.50"	2
7	3502900023	Sheave Support Weld	2	41	7950170000	Lockwasher, 0.44" ID	16
8	3249000002	Cable Guide Weld	2	42	7115170850	Capscrew, 0.44"-14NC x 1.00"	16
9	3510100051	Dual Winch Mount Weld	1	43	7660152601	Locknut, 0.31"-18NC	8
10	3691000134	Pin Weld	2	44	4567222022	Hose Assembly	1
11	3320000011	Cylinder Assembly	1	45	7912000001	Tube Assembly	1
12	3320000012	Cylinder Assembly	1	46	4570000008	Hose Assembly	1
13	3320000007	Cylinder Assembly	1	47	7445060645	Elbow	4
14	3691000075	Pin Weld	4	48	7445060648	Tee	1
15	3691000081	Pin Weld	2	49	7445060646	Elbow	1
16	4706000067	Plate	1	50	7445060647	Tee	1
17	4691000133	Pin	1	51	7443000030	Tee	1
18	4691000179	Pin	1	52	7912000002	Tube Assembly	1
19	4679000005	Wear Pad	1	53	7935000001	Counterbalance Valve	1
20	4679000004	Wear Pad	1	54	7950150161	Flatwasher, 0.31 ID	8
21	4706000160	Plate	1	55	7111151650	Capscrew, 0.31"-18NC x 2.00"	2
22	7970000138	Winch - 10,000 lb Worm Gear - LH	1	56	4706001255	Plate	1
23	7970000139	Winch - 10,000 lb Worm Gear - RH	1	57	7950140161	Flatwasher, 0.25" ID	2
24	7626000013	Orbit Motor	2	58	7445080843	Adapter	4
25	7754000006	Retaining Ring	6	59	7445060843	Adapter	4
26	7809000001	Sheave	2	60	4567322064	Hose Assembly	2
27	7754000018	Retaining Ring	2	61	7445081043	Adapter	4
28	7440030000	Grease Fitting	10	62	4567122055	Hose Assembly	2
29	7115180850	Capscrew, 0.50"-13NC x 1.00"	2	63	4567332075	Hose Assembly	4
30	7115181450	Capscrew, 0.50"-13NC x 1.50"	4	64	7443000137	Elbow	1
31	7660182600	Locknut, 0.50"-13NC	4	65	7443000023	Elbow	4
32		Not Required		66	7445060643	Adapter	2
33	7950180000	Lockwasher, 0.50" ID	2	67	7445060672	Elbow	1
34	7115171250	Capscrew, 0.44"-14NC x 1.50"	6	68	7935000174	Relief Valve	2
				69	7253000002	Grease Fitting	10

12 TON WRECKER BOOM - DUAL 10,000 LB WINCH

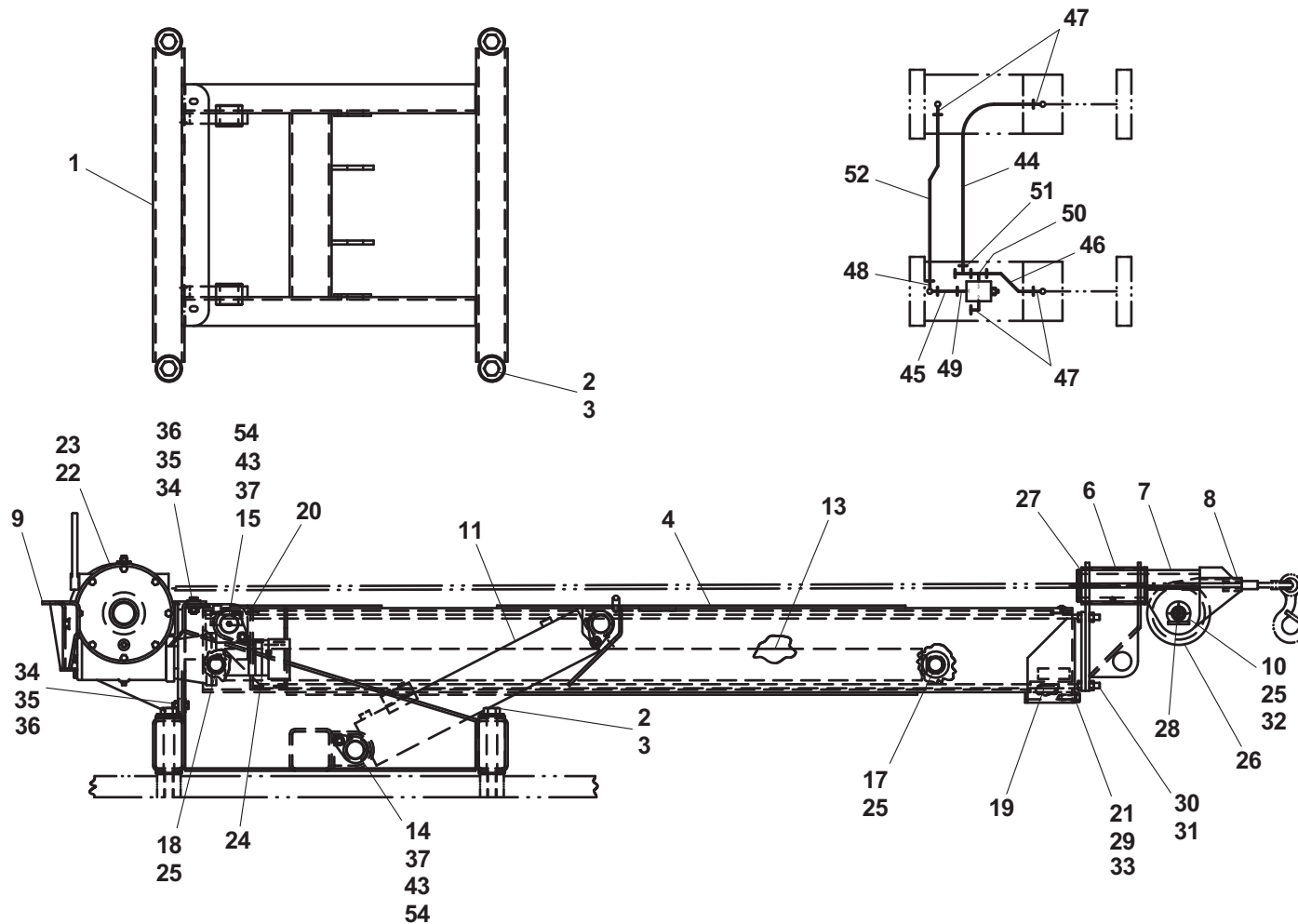

12 TON WRECKER BOOM - DUAL 10,000 LB WINCH

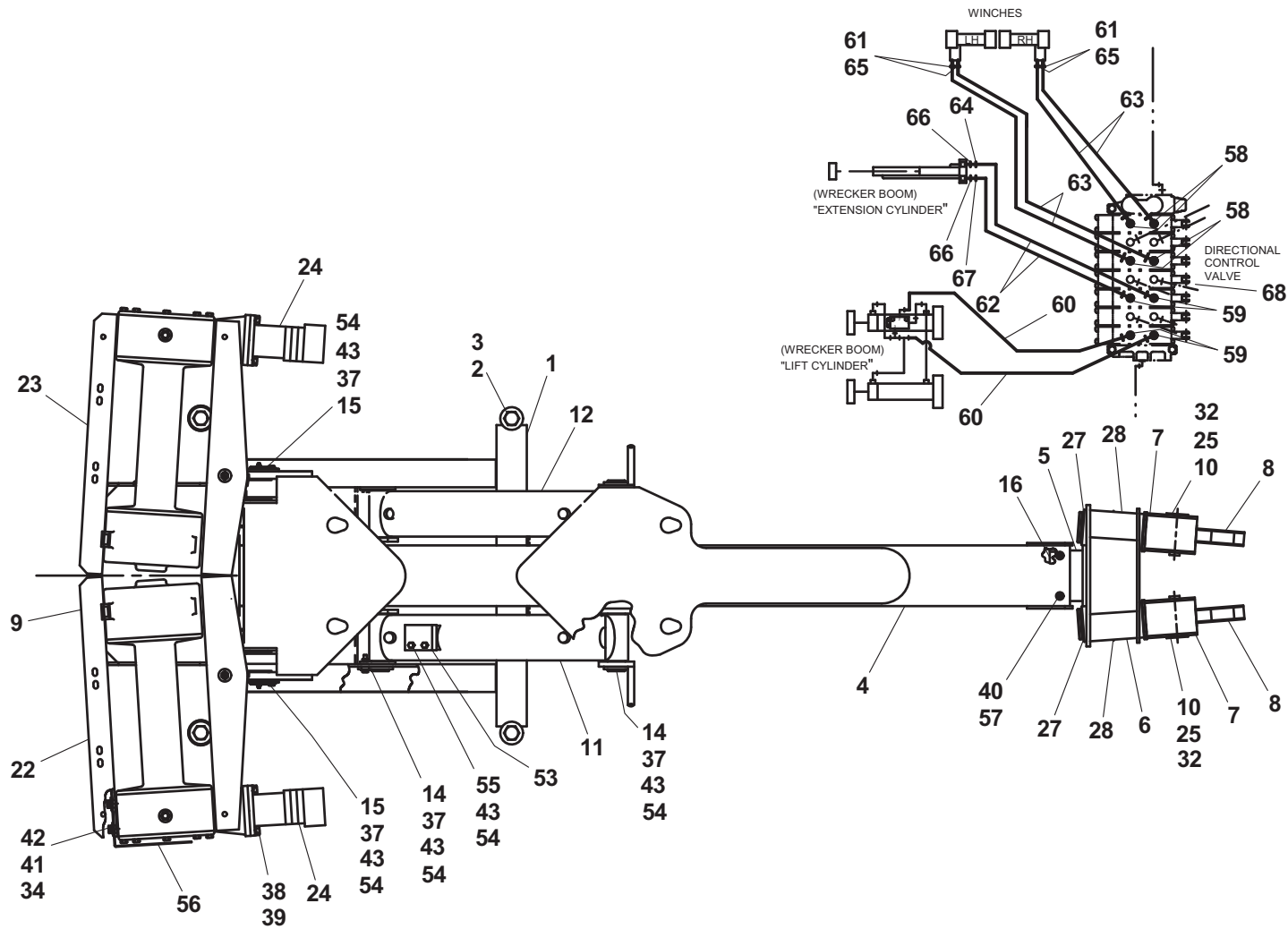

THIS PAGE INTENTIONALLY LEFT BLANK

12 TON WRECKER BOOM - DUAL 12,000 LB WINCH

ITEM	PART NO.	DESCRIPTION	QTY	ITEM	PART NO.	DESCRIPTION	QTY
1	3512100071	Frame Weld	1	35	7950160162	Flatwasher, 0.38" ID	28
2	7115245650	Capscrew, 0.88"-9NC x 7.00"	4	36	7660172601	Locknut, 0.44"-14NC	6
3	7950240161	Flatwasher, 0.88" ID	4	37	7115151250	Capscrew, 0.31"-18NC x 1.50"	6
4	3512100004	Base Boom Weld	1	38	7115181050	Capscrew, 0.50"-13NC x 1.25"	4
5	3512100005	Fly Boom Weld	1	39	7950180400	Lockwasher, 0.50" ID	4
6	3502100024	Boom Nose Weld	1	40	7118140418	Capscrew, 0.25"-20NC x 0.50"	2
7	3502900023	Sheave Support Weld	2	41	7950170000	Lockwasher, 0.44" ID	16
8	3249000002	Cable Guide Weld	2	42	7115170850	Capscrew, 0.44"-14NC x 1.00"	16
9	3512100089	Dual Winch Mount Weld	1	43	7660152601	Locknut, 0.31"-18NC	8
10	3691000134	Pin Weld	2	44	4567222022	Hose Assembly	1
11	3320000011	Cylinder Assembly	1	45	7912000001	Tube Assembly	1
12	3320000012	Cylinder Assembly	1	46	4570000008	Hose Assembly	1
13	3320000007	Cylinder Assembly	1	47	7445060645	Elbow	4
14	3691000075	Pin Weld	4	48	7445060648	Tee	1
15	3691000081	Pin Weld	2	49	7445060646	Elbow	1
16	4706000067	Plate	1	50	7445060647	Tee	1
17	4691000133	Pin	1	51	7443000030	Tee	1
18	4691000179	Pin	1	52	7912000002	Tube Assembly	1
19	4679000005	Wear Pad	1	53	7935000001	Counterbalance Valve	1
20	4679000004	Wear Pad	1	54	7950150161	Flatwasher, 0.31 ID	8
21	4706000160	Plate	1	55	7111151650	Capscrew, 0.31"-18NC x 2.00"	2
22	7970000025	Winch - 12,000 lb Worm Gear - LH	1	56	4706001255	Plate	1
23	7970000026	Winch - 12,000 lb Worm Gear - RH	1	57	7950140161	Flatwasher, 0.25" ID	2
24	7626000013	Orbit Motor	2	58	7445080843	Adapter	4
25	7754000006	Retaining Ring	6	59	7445060843	Adapter	4
26	7809000001	Sheave	2	60	4567322064	Hose Assembly	2
27	7754000018	Retaining Ring	2	61	7445081043	Adapter	4
28	7440030000	Grease Fitting	10	62	4567122055	Hose Assembly	2
29	7115180850	Capscrew, 0.50"-13NC x 1.00"	2	63	4567332075	Hose Assembly	4
30	7115181450	Capscrew, 0.50"-13NC x 1.50"	4	64	7443000137	Elbow	1
31	7660182600	Locknut, 0.50"-13NC	4	65	7443000023	Elbow	4
32		Not Required		66	7445060643	Adapter	2
33	7950180000	Lockwasher, 0.50" ID	2	67	7445060672	Elbow	1
34	7115171250	Capscrew, 0.44"-14NC x 1.50"	6	68	7701000068	Plug	2
				69	7253000002	Grease Fitting	10

12 TON WRECKER BOOM - DUAL 12,000 LB WINCH

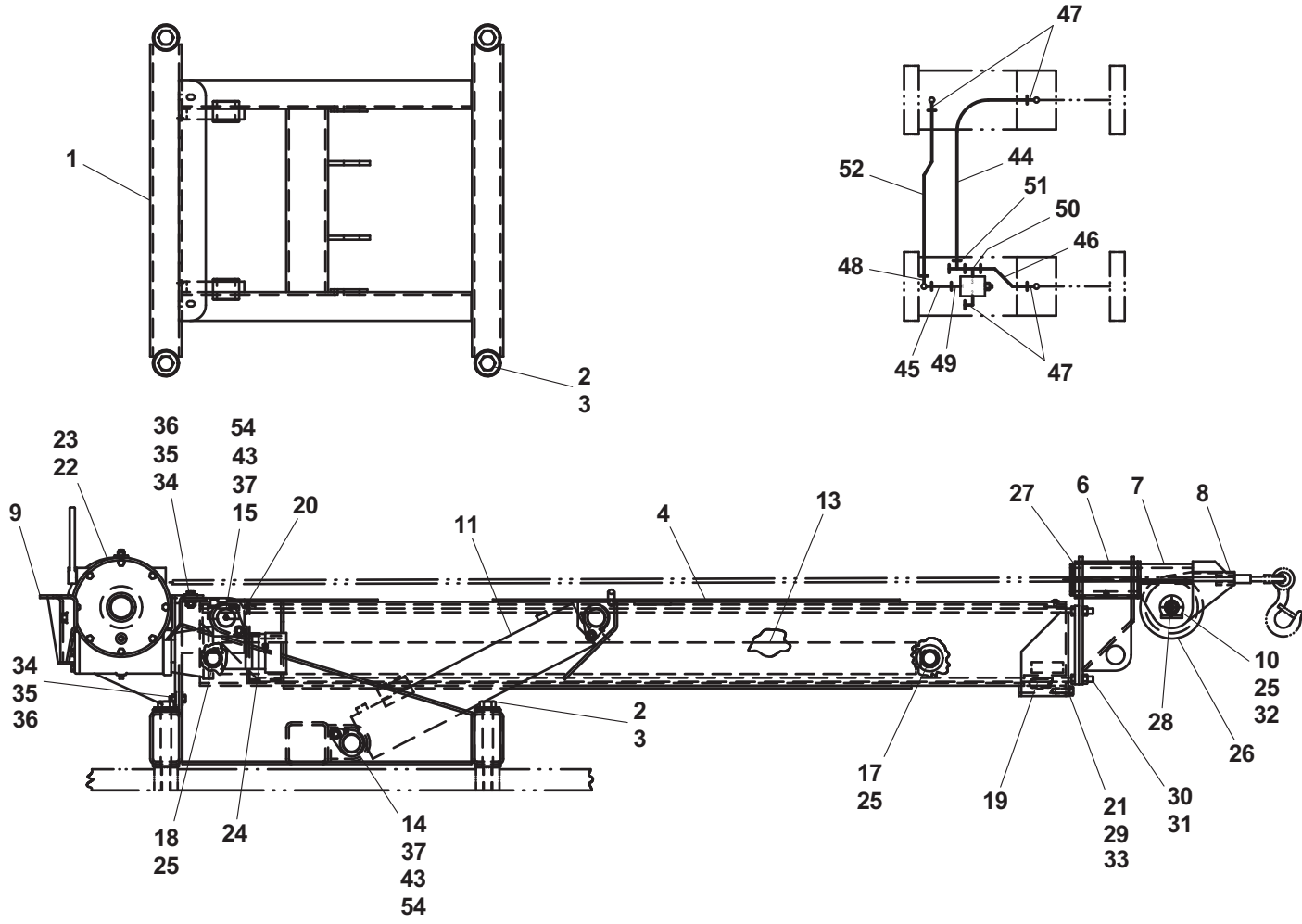

12 TON WRECKER BOOM - DUAL 12,000 LB WINCH

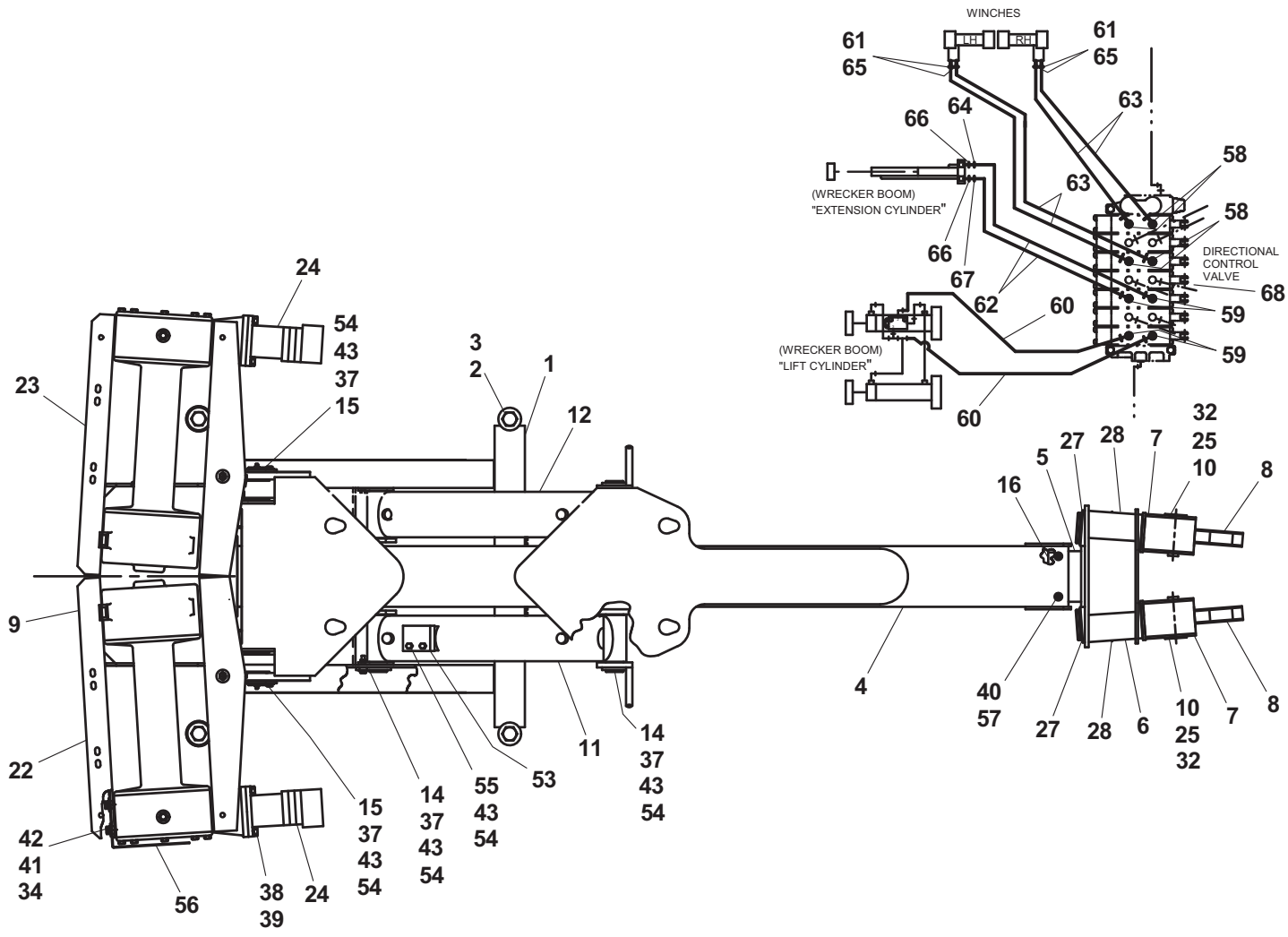

THIS PAGE INTENTIONALLY LEFT BLANK

WRECKER BOOM SINGLE / DUAL WINCH - CABLE TENSIONER

ITEM	PART NO.	DESCRIPTION	QTY
1	3706000099	Pressure Plate Weld (8,000 lb winch)	1
	3706000024	Pressure Plate Weld (10,000 lb winch)	
	3706000052	Pressure Plate Weld (12,000 lb winch)	
2	3017000003	Angle Weld - LH (8,000 & 10,000 lb winch)	1
	3017000024	Angle Weld - LH (12,000 lb winch)	
3	3017000002	Angle Weld - RH (8,000 & 10,000 lb winch)	1
	3017000023	Angle Weld - RH (12,000 lb winch)	
4	7843000004	Compression Spring	2
5	7950180161	Flatwasher, 0.50" ID (8,000 & 10,000 lb winch)	2
	7950200161	Flatwasher, 0.63" ID (12,000 lb winch)	
6	7950180161	Flatwasher, 0.50" ID	2
7	7660182600	Locknut, 0.50"-13NC	2
8	7115161050	Capscrew, 0.38"-16NC x 1.25"	4
9	7950150161	Flatwasher, 0.31" ID	8
10	7660162601	Locknut, 0.38"-16NC	4

WRECKER BOOM SINGLE / DUAL WINCH - CABLE TENSIONER

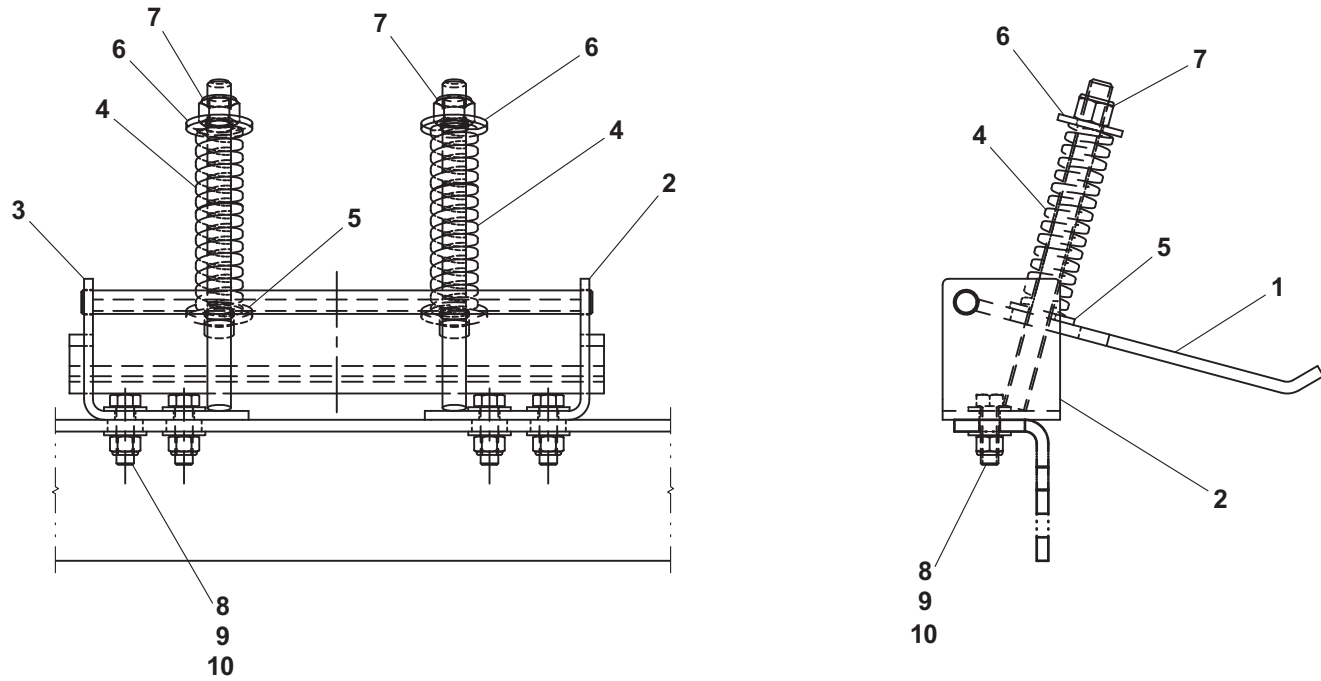

WINCH MOUNTED LIGHT PYLON

ITEM	PART NO.	DESCRIPTION	QTY
1	3263000011	Channel Weld	1
2	3178000060	Mounting Bracket Weld (17" Pylon)	2
	3178000530	Mounting Bracket Weld (20" Pylon)	
	3178000100	Mounting Bracket Weld (27" Pylon)	
	3636000046	Mounting Bracket Weld (32" Pylon)	
3	7115161050	Capscrew, 0.38"-16NC x 1.25"	4
4	7950150161	Flatwasher, 0.31" ID	10
5	7660162601	Locknut, 0.38"-16NC	8
6	7280000001	Clip (17", 20" & 27" Pylon)	2
	7280000001	Clip (32" Pylon)	3
7	7790100856	Screw, #10 x 0.50" (17", 20" & 27" Pylon)	2
	7790100856	Screw, #10 x 0.50" (32" Pylon)	3
8	7115160850	Capscrew, 0.38"-16NC x 1.00"	4

WINCH MOUNTED LIGHT PYLON

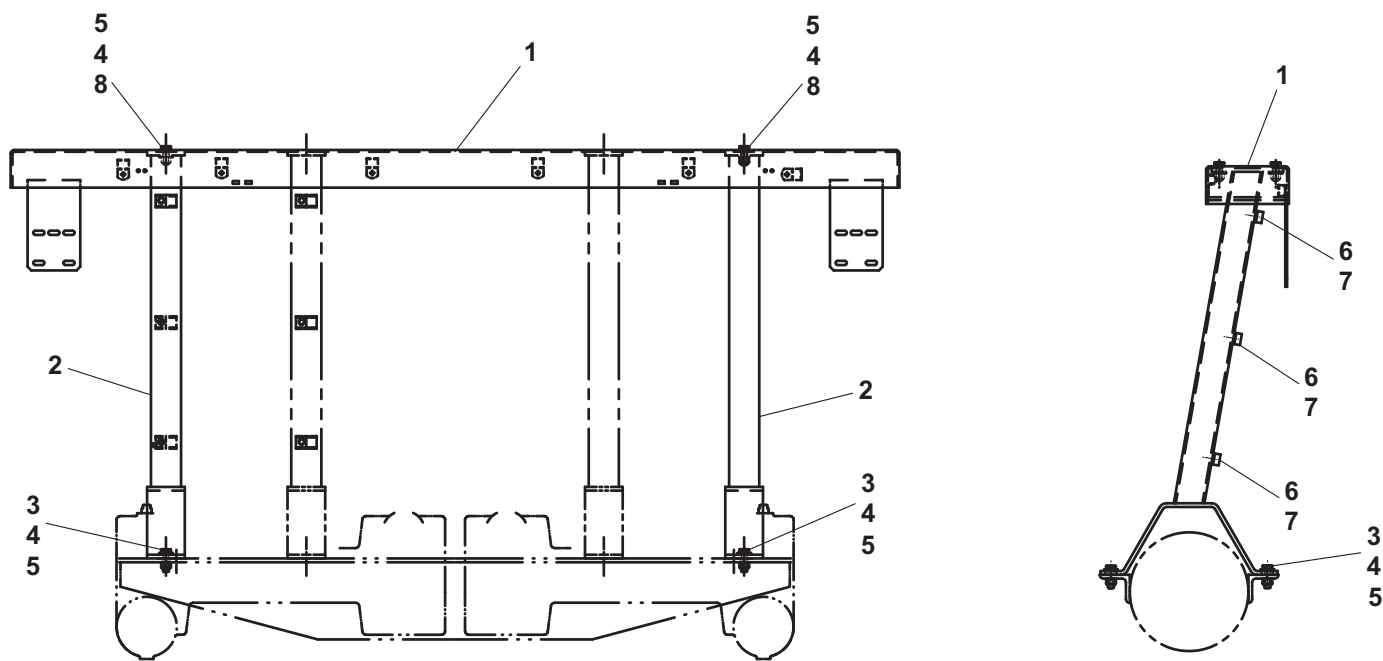

8 / 12 TON DUAL WINCH FREE SPOOL

ITEM	PART NO.	DESCRIPTION	QTY
1	3587000007	Lever Weld	2
2	4178000167	Bracket - RH	1
	4178000166	Bracket - LH	1
3	3587000008	Handle Weld (8,000 & 10,000 lb Winch)	2
	3587000011	Handle Weld (12,000 lb Winch)	2
4	7843000010	Spring	2
5	7950180161	Flatwasher, 0.50" ID (8,000 & 10,000 lb Winch)	2
	7950180161	Flatwasher, 0.50" ID (12,000 lb Winch)	4
6	7308000013	Yoke Assembly	2
7	7660180030	Hex Nut, 0.50"-20NF	2
8	4551000005	T-Handle	2
9	7690051641	Pin	2
10	7115161250	Capscrew, 0.38"-16NC x 1.50"	2
11	7950160162	Flatwasher, 0.38" ID	4
12	7660160000	Hex Nut, 0.38"-16NC	2
13	4575060600	Key	2
14	7690102041	Pin	2

8 / 12 TON DUAL WINCH FREE SPOOL

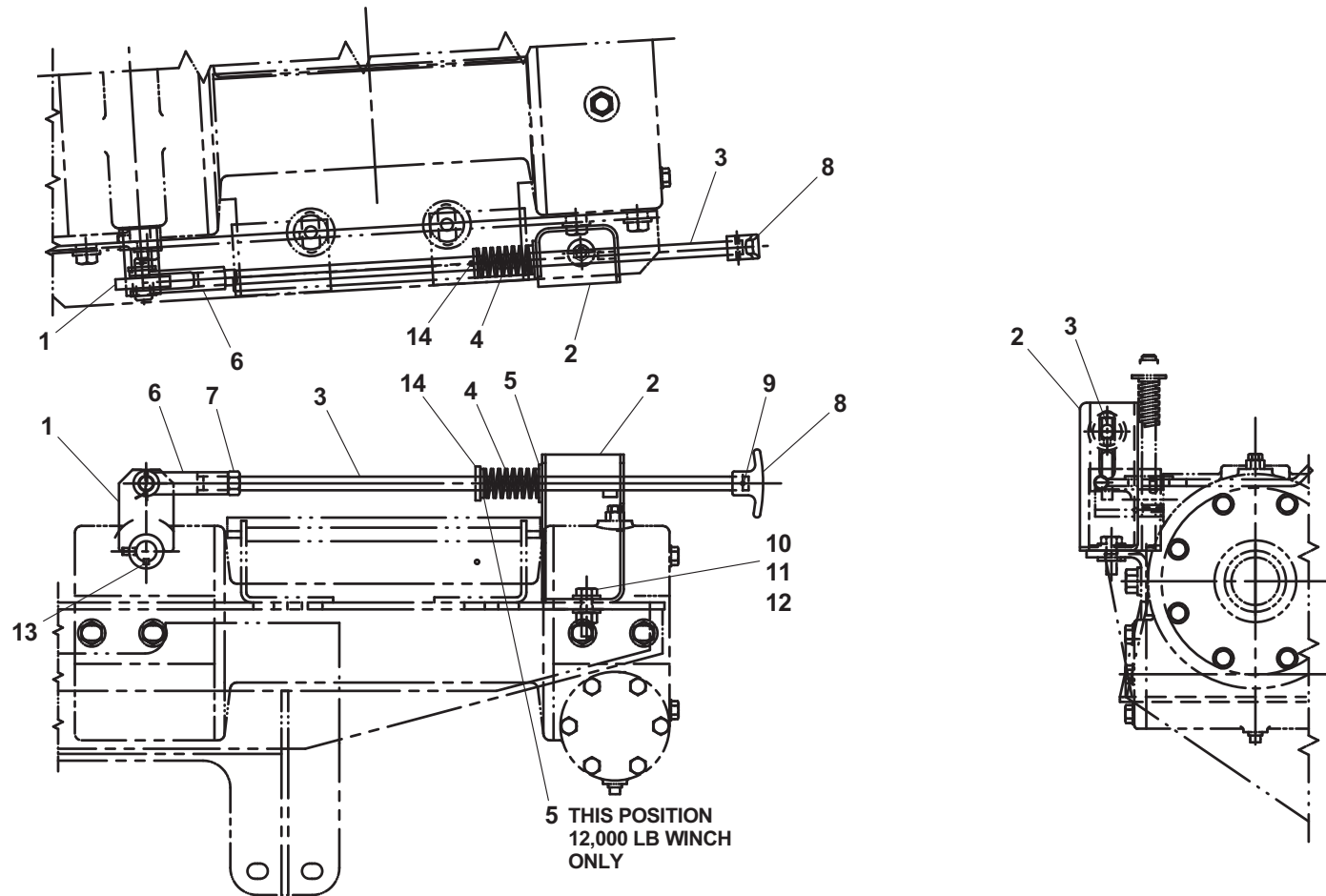

R H Free Spool Handle, shown
8,000 lb Winch, shown

UNDERLIFT BOOM - COMPLETE

ITEM	PART NO.	DESCRIPTION	QTY
1	3511100071	Boom Assembly	1
2	3320000228	Cylinder Assembly	1
3	3691000060	Pin Weld	2
4	3691000063	Pin Weld	1
5	3691000066	Pin Weld	2
6	3691000086	Pin Weld	2
7	7754000033	Retaining Ring	5
8	7115162650	Capscrew, 0.38"-16NC x 3.25"	2
9	7660162601	Locknut, 0.38"-16NC	2
10	7440030000	Grease Fitting	7

UNDERLIFT BOOM - COMPLETE

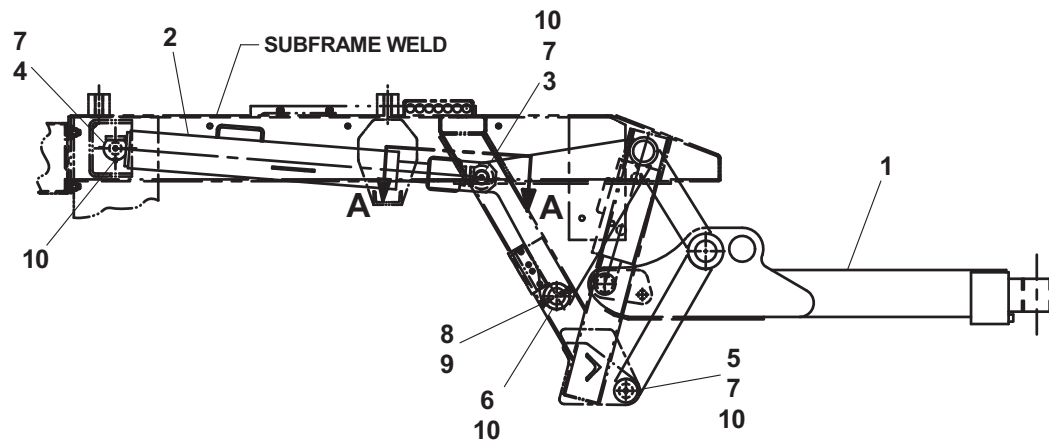
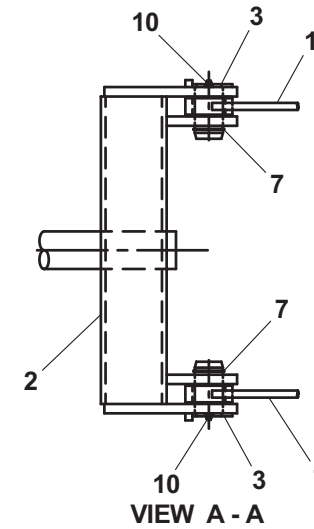
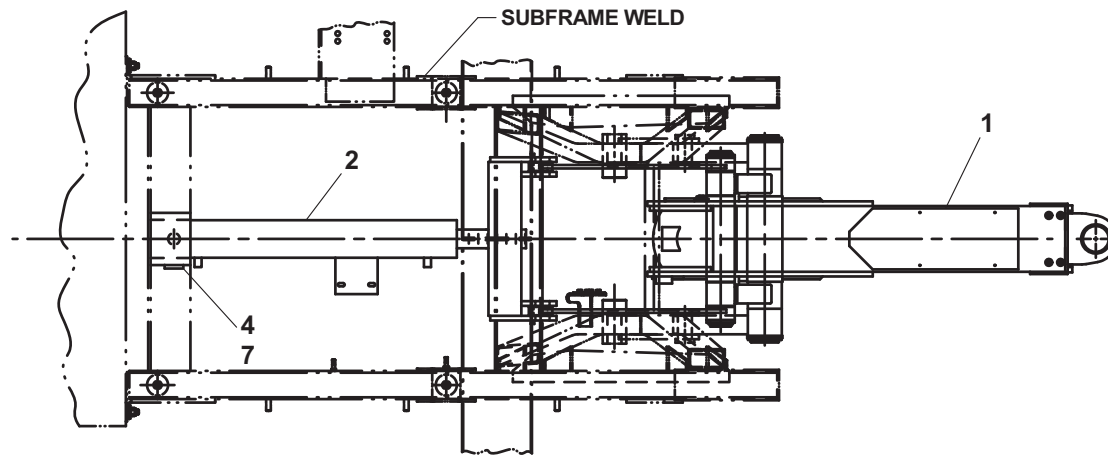

UNDERLIFT BOOM ASSEMBLY

ITEM	PART NO.	DESCRIPTION	QTY
1	3511100059	Base Section Boom Weld	1
2	3170000487	Fly Section Boom Weld	1
3	3320000016	Cylinder Assembly	1
4	7320000078*	Cylinder Assembly	1
5	3512100018	Arm Weld - LH	1
6	3512100017	Arm Weld - RH	1
7	3511100054	Tube Weld	2
8	3511100008	Tube Weld	2
9	4691000054	Pin	1
10	4949000019	Washer	2
11	4949000018	Washer	2
12	3691000077	Pin Weld	1
13	4691000121	Pin	1
14	4691000120	Pin	1
15	4679000046	Pad	2
16	4812000038	Shim	1
17	4017000459	Angle	2
18	7754000017	Retaining Ring	2
19	7754000018	Retaining Ring	2
20	7754000019	Retaining Ring	4
21	7115183250	Capscrew, 0.50"-13NC x 4.00"	1
22	7660182600	Locknut, 0.50"-13NC	1
23	7440030000	Grease Fitting	17
24	7114140418	Capscrew, 0.25"-20NC x 0.50"	4
25	7118151424	Capscrew, 0.31"-18NC x 1.75"	1
26	7950140153	Flatwasher, 0.25" ID	4
27	7950140003	Lockwasher, 0.25" ID	4
28	4691000197	Pin	1
29	7115183650	Capscrew, 0.50"-13NC x 4.50"	1
30	7660182601	Locknut, 0.50"-13NC	1
31	4949000047	Washer, 5.00" OD	2

* Service Seal Kit, P/N 9577820242

UNDERLIFT BOOM ASSEMBLY

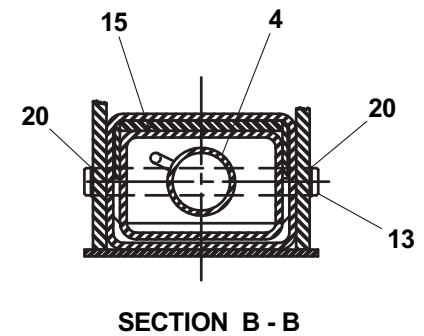
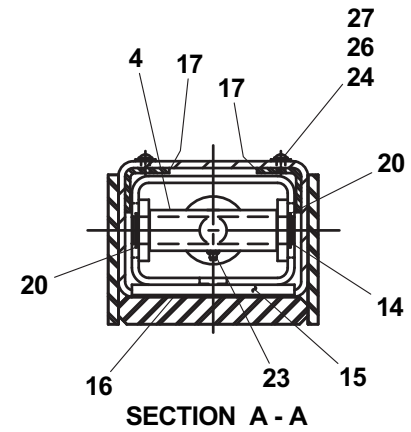
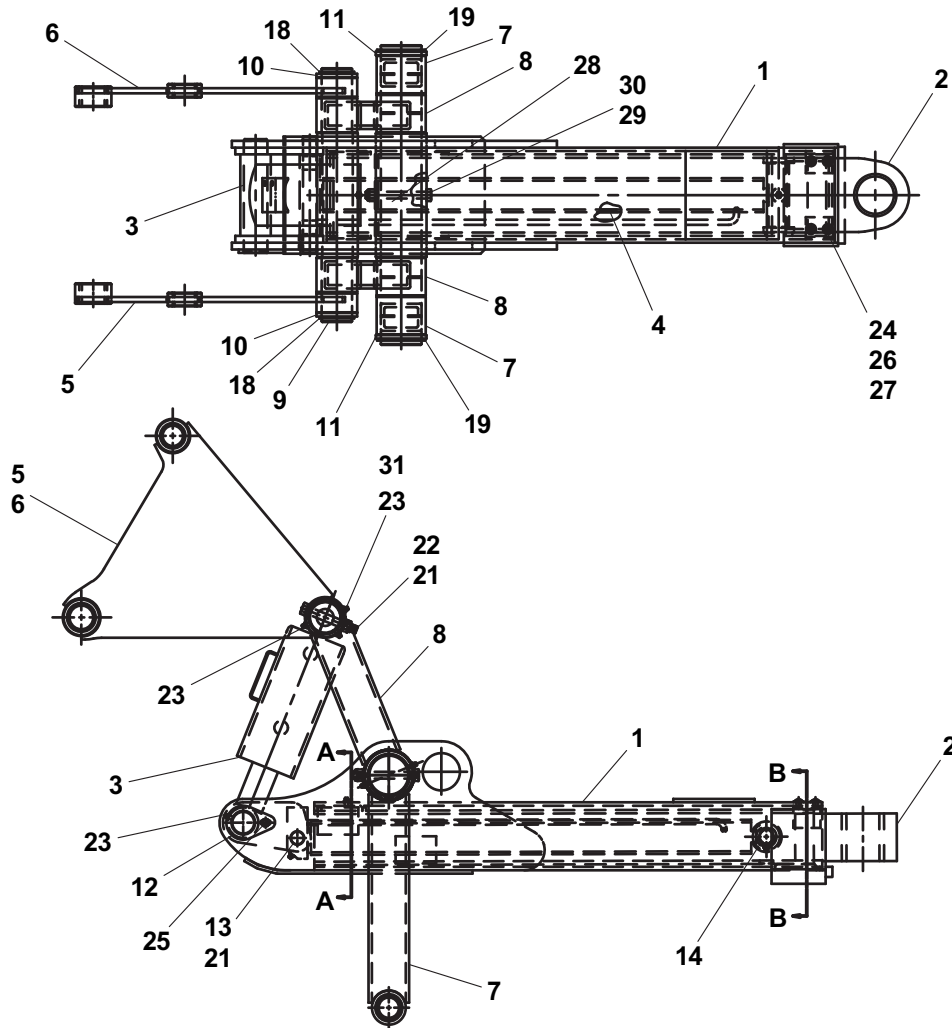

MANUAL L-ARM WHEEL LIFT GRID AND STORAGE

ITEM	PART NO.	DESCRIPTION	QTY
1	3512880076	Pivot Tube Weld	1
2	3511880091	Grid Weld - LH	1
3	3511880090	Grid Weld - RH	1
4	3551000036	T-Handle	2
5	3511880049	L-Arm Weld	2
6	4691000427	Pivot Pin	1
7	7754000024	Retaining Ring	1
8	4254000006*+	Rod Cap	2
9	4691000188*+	Pin	2
10	4763000184*+	Rod	2
11	7843000006*+	Compression Spring	2
12	7440030000*+	Grease Fitting	2
13	3502880041	Storage Tube Weld	2
14	7114140818	Capscrew, 0.25"-20NC x 1.00"	8
15	7950140161	Flatwasher, 0.25" ID	8
16	7413000002	Nutsert, 0.25"-20NC	8
17	4706002098	Plate	2
18	7115160850	Capscrew, 0.38"-16NC x 1.00"	2
19	7950160251	Flatwasher, 0.38" ID	2
20	7660161600	Locknut, 0.38"-16NC	2
21	7679000010	Pad	2
22	7790101276	Screw, #10-24NC x 0.75"	4

* also available in Grid Weld, LH, P/N 3511880091

+ also available in Grid Weld, RH, P/N 3511880090

MANUAL L-ARM WHEEL LIFT GRID AND STORAGE

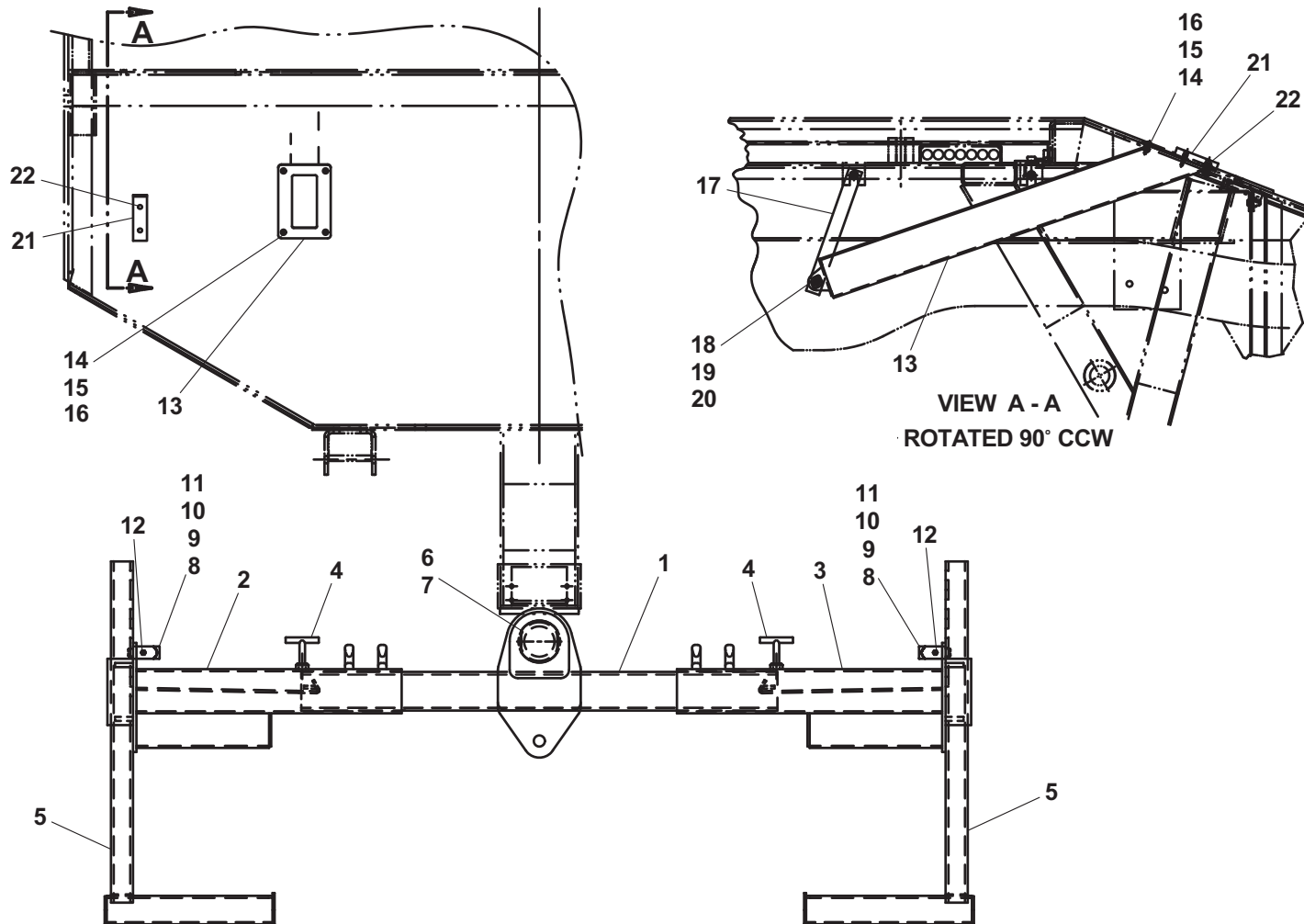

MANUAL T37 PIVOTING WHEEL LIFT GRID AND STORAGE

ITEM	PART NO.	DESCRIPTION	QTY
1	3511880082	Pivot Tube Weld	1
2	3484000017*	Grid Weld - LH	1
3	3484000016+	Grid Weld - RH	1
4	4259000002*	Pivot Casting, LH	1
5	4259000001+	Pivot Casting, RH	1
6	4691000357*+	Pin	2
7	7754000037*+	Retaining Ring	2
8	3551000036*+	T-Handle	2
9	4691000427	Pivot Pin	1
10	7754000024	Retaining Ring	1
11	4691000354*+	Pin	2
12	7950200000*+	Lockwasher, 0.63" ID	2
13	4691000186*+	Pin	2
14	7843000006*+	Spring	2
15	4254000005*+	Cap	2
16	4763000184*+	Rod	2
17	7786000006*+	Screw, 0.75"-10NC x 0.63"	2
18	7843000016*+	Compression Spring	2
19	4691000183*+	Pin	2
20	7440030000*+	Grease Fitting	6
21	3020000029	L-Arm Weld - LH	1
22	3020000030	L-Arm Weld - RH	1
23	3502880041	Storage Tube Weld	2
24	7114140818	Capscrew, 0.25"-20NC x 1.00"	8
25	7950140161	Flatwasher, 0.25" ID	8
26	7660142600	Locknut, 0.25"-20NC	8
27	4706002098	Plate	2
28	7115160850	Capscrew, 0.38"-16NC x 1.00"	2
29	7950160251	Flatwasher, 0.38" ID	2
30	7660161600	Locknut, 0.38"-16NC	2

* also available in Grid Assembly, LH, P/N 3484000047

+ also available in Grid Assembly, RH, P/N 3484000046

MANUAL T37 PIVOTING WHEEL LIFT GRID AND STORAGE

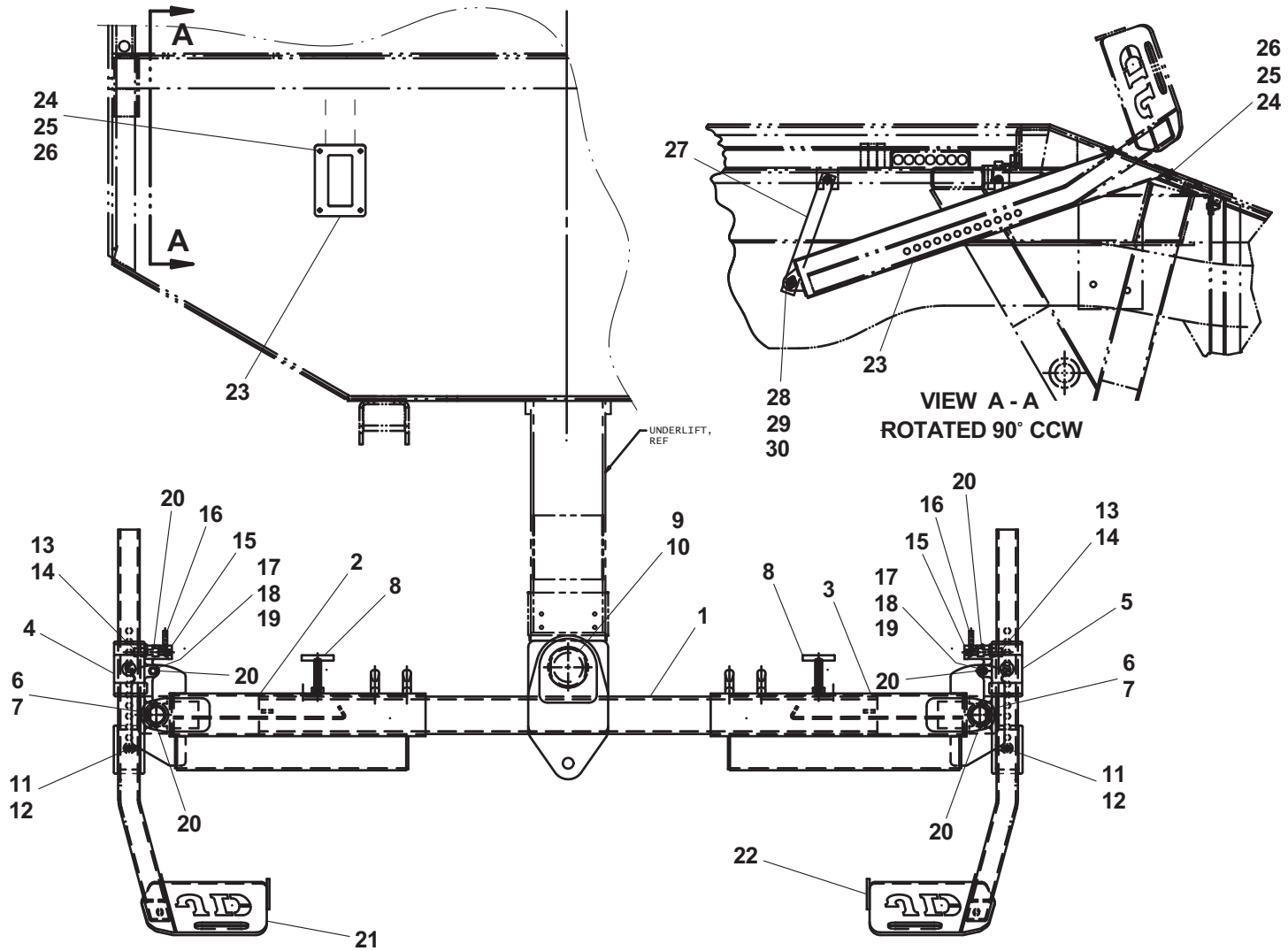

HYDRAULIC COMPONENTS - PTO VERSION +

ITEM	PART NO.	DESCRIPTION	QTY	ITEM	PART NO.	DESCRIPTION	QTY
1	See Note 1	PTO	1	33	7115152650	Capscrew, 0.31"-18NC x 3.25"	2
2	See Note 1	Pump, Fittings & Mtg. Hardware	1	34	7950150161	Flatwasher, 0.31" ID	4
3	See Note 1	Hose Assembly	1	35	7660152601	Locknut, 0.31"-18NC	4
4	7444080860	Elbow	1	36	7111151650	Capscrew, 0.31"-18NC x 2.00"	2
5	7445161619	Adapter	1	37	7430000003	Filter Assembly	1
6	See Note 1	Hose Assembly	1	38	7470000002	Gauge	1
7	7445081043	Adapter	1	39	7431000001^	Filter Element	1
8	4567362021*	Hose Assembly	1	40	7274000113	Clamp Body Insert	4
9	7445121619	Adapter	1	41	7274000114	Stacking Bolt	6
10	7445121245	Elbow	1	42	7274000117	Clamp Bolt	2
11	7443000129	Reducer	6	43	7274000116	Clamp Cover	1
12	7445060645	Elbow	10	44	7274000115	Locking Plate	2
13	7443000108	Restrictor	1	45	7274000041	Clamp	3
14	4567320044*	Hose Assembly	2	46	7111140850	Capscrew, 0.25"-20NC x 1.00"	3
15	4567120115	Hose Assembly	4	47	7950140000	Lockwasher, 0.25" ID	3
16	7445040645	Elbow	5	48	7660140000	Hex Nut, 0.25"-20NC	3
17	7445040446	Elbow	2	49	7274000042	Clamp	2
18	7445060647	Tee	2	50	7660152601	Locknut, 0.31"-18NC	2
19	7912000030	Tube Assembly	1	51	7819000005	Sleeve	1
20	7912000013	Tube Assembly	1				
21	7912000005	Tube Assembly	1				
22	7912000017	Tube Assembly	1				
23	7445040443	Adapter	1				
24	7445040445	Elbow	1				
25	7443000105	Reducer	2				
26	7443000106	Reducer Nut	2				
27	7445040643	Adapter	1				
28	4567210021*	Hose Assembly	1				
29	4567210017*	Hose Assembly	1				
30	7935000001	Counterbalance Valve	1				
31	7935000016	Check Valve	1				
32	7935000307	Counterbalance Valve	1				

Note: For Clutch Pump Version, consult factory for parts.

^ also available in Filter Assembly, P/N 7430000003

* included in Hose Kit, P/N 7577000464

Note 1: Varies depending on chassis, transmission and PTO type. Consult factory for part numbers.

HYDRAULIC COMPONENTS - PTO VERSION +

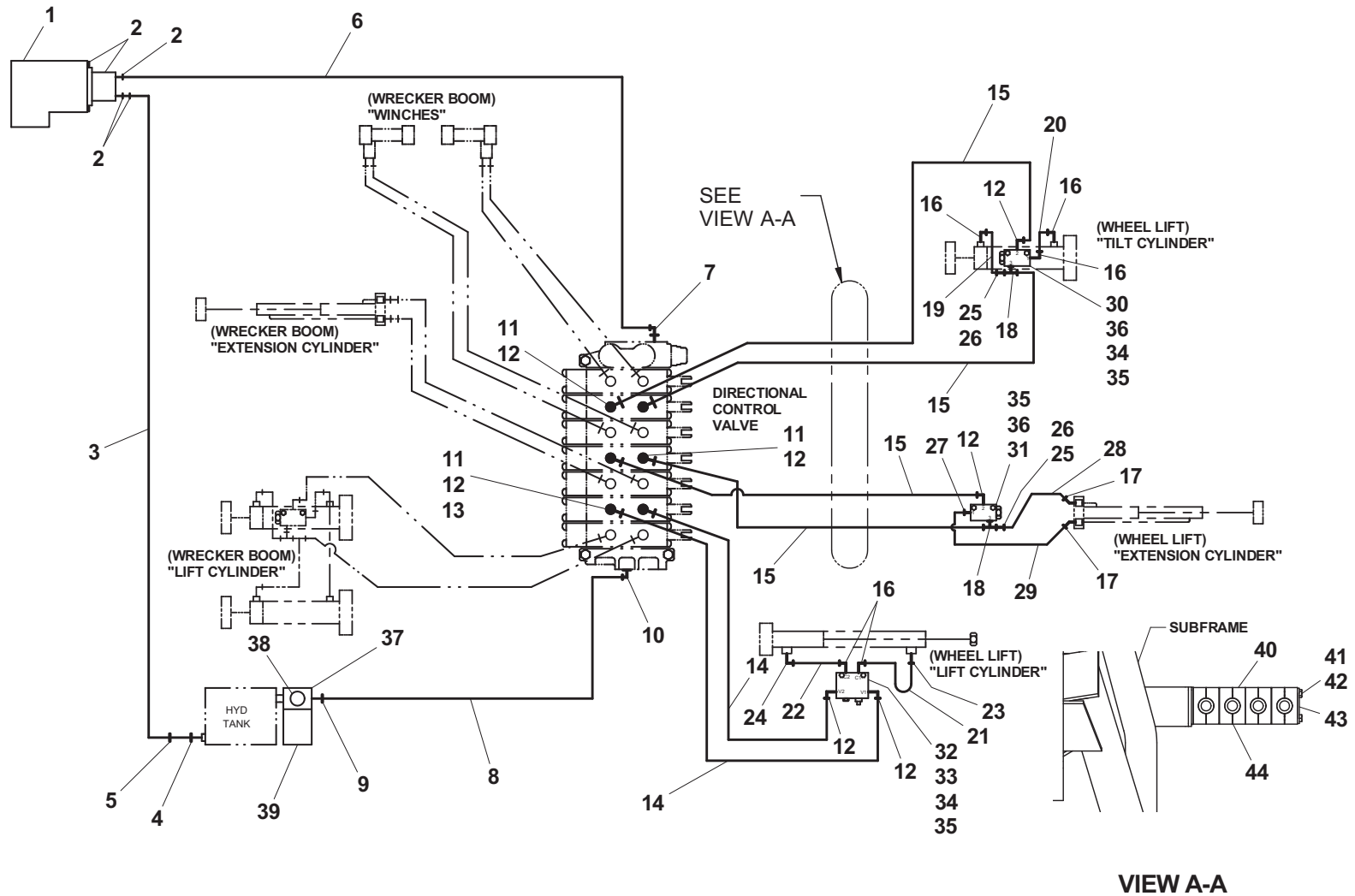

Item #45, Clamp; item #46, Capscrew; item #47, Lockwasher;
 item #48, Hex Nut; item #49, Clamp; item #50, Locknut and item #51, Sleeve; not shown

DUAL CONTROLS - 3 BANK

ITEM	PART NO.	DESCRIPTION	QTY
1	4763000154	Rod	7
2	7935000261	Control Valve	1
3	7690101200	Clevis Pin	3
4	7691000056	Cotter Hairpin	3
5	7990000003	Yoke	3
6	7690141200	Clevis Pin	3
7	7690000810	Cotter Pin	3
8	7660140230	Jam Nut, 0.25"-28NF	3
9	7765000006	Rod End	3
10	7660160000	Hex Nut, 0.38"-16NC	3
11	7115161250	Capscrew, 0.38"-16NC x 1.50"	3
12	7950160252	Flatwasher, 0.38" ID	3
13	7660162601	Locknut, 0.38"-16NC	3
14	4763000150	Handle	6
15	7551000002	Knob	6
16	3763000157	Rod Weld	1
17	3763000158	Rod Weld	1
18	3763000159	Rod Weld	1
19	7443000048	Plug Fitting	8
20	7701000068	Plug Shut-off	2

DUAL CONTROLS - 3 BANK

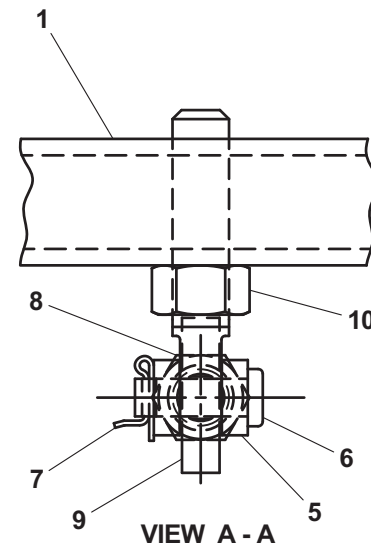
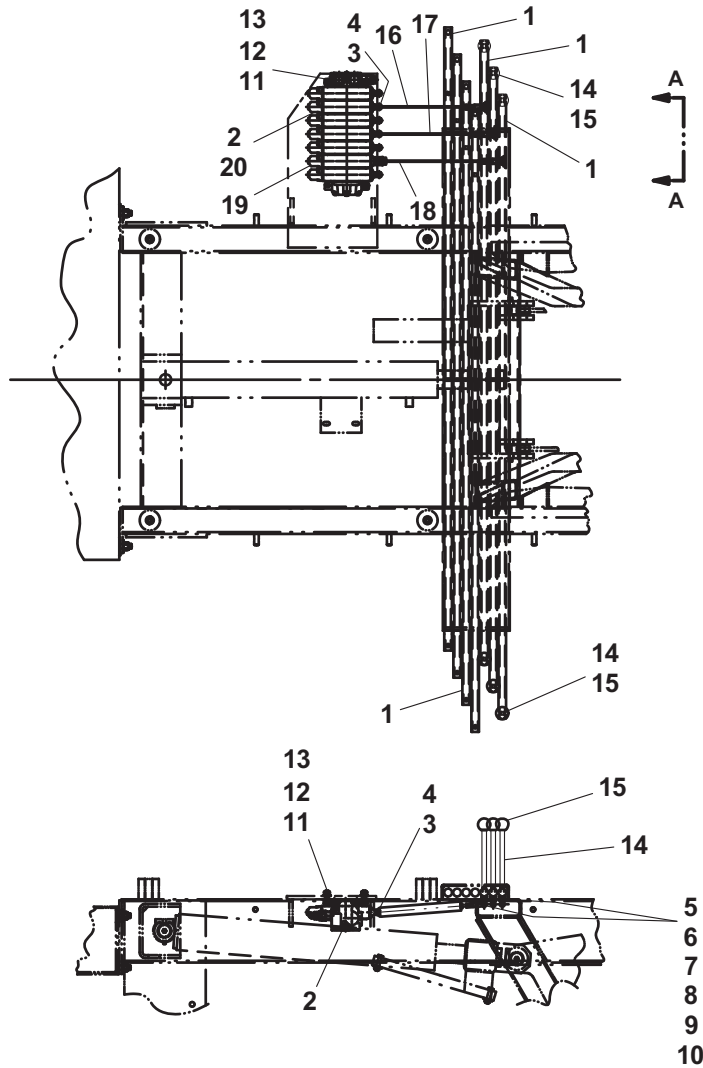

DUAL CONTROLS - 4 BANK

ITEM	PART NO.	DESCRIPTION	QTY
1	4763000154	Rod	7
2	7935000261	Control Valve	1
3	7690101200	Clevis Pin	4
4	7691000056	Cotter Hairpin	4
5	7990000003	Yoke	4
6	7690141200	Clevis Pin	4
7	7690000810	Cotter Pin	4
8	7660140230	Jam Nut, 0.25"-28NF	4
9	7765000006	Rod End	4
10	7660160000	Hex Nut, 0.38"-16NC	4
11	7115161250	Capscrew, 0.38"-16NC x 1.50"	3
12	7950160252	Flatwasher, 0.38" ID	3
13	7660162601	Locknut, 0.38"-16NC	3
14	4763000150	Handle	6
15	4763000151	Handle	2
16	7551000002	Knob	8
17	3763000154	Rod Weld	1
18	3763000157	Rod Weld	1
19	3763000158	Rod Weld	1
20	3763000159	Rod Weld	1
21	7443000048	Plug Fitting	6

DUAL CONTROLS - 4 BANK

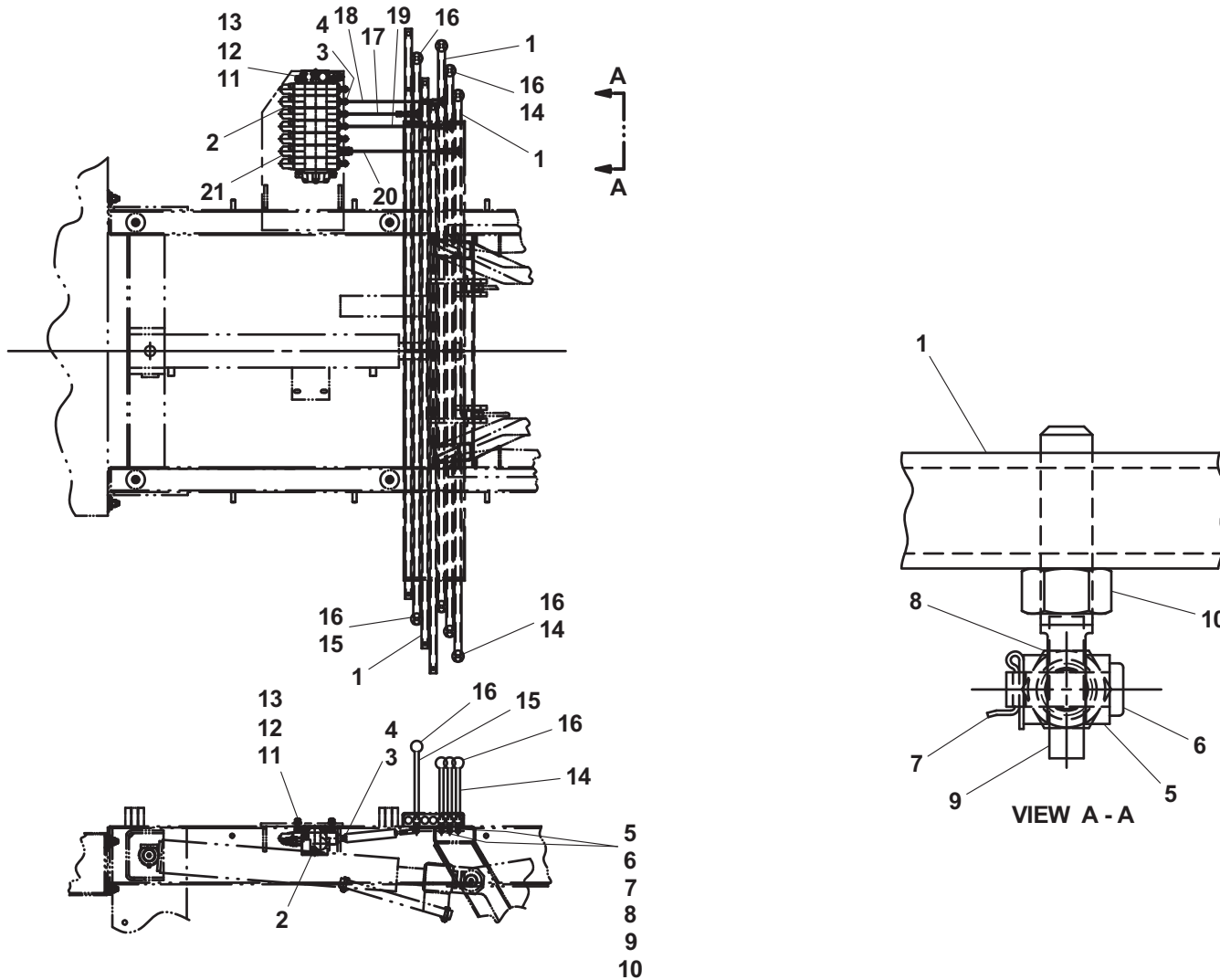

DUAL CONTROLS - 6 BANK

ITEM	PART NO.	DESCRIPTION	QTY
1	4763000154	Rod	7
2	7935000261	Control Valve	1
3	7690101200	Clevis Pin	6
4	7691000056	Cotter Hairpin	6
5	7990000003	Yoke	6
6	7690141200	Clevis Pin	6
7	7690000810	Cotter Pin	6
8	7660140230	Jam Nut, 0.25"-28NF	6
9	7765000006	Rod End	6
10	7660160000	Hex Nut, 0.38"-16NC	6
11	7115161250	Capscrew, 0.38"-16NC x 1.50"	3
12	7950160252	Flatwasher, 0.38" ID	3
13	7660162601	Locknut, 0.38"-16NC	3
14	4763000150	Handle	6
15	4763000151	Handle	6
16	7551000002	Knob	12
17	3763000154	Rod Weld	1
18	3763000155	Rod Weld	1
19	3763000156	Rod Weld	1
20	3763000157	Rod Weld	1
21	3763000158	Rod Weld	1
22	3763000159	Rod Weld	1
23	7443000048	Plug Fitting	2

DUAL CONTROLS - 6 BANK

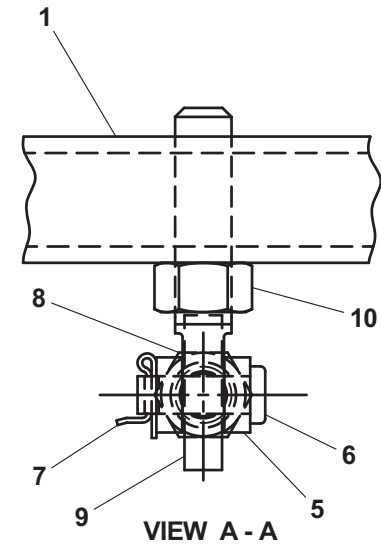
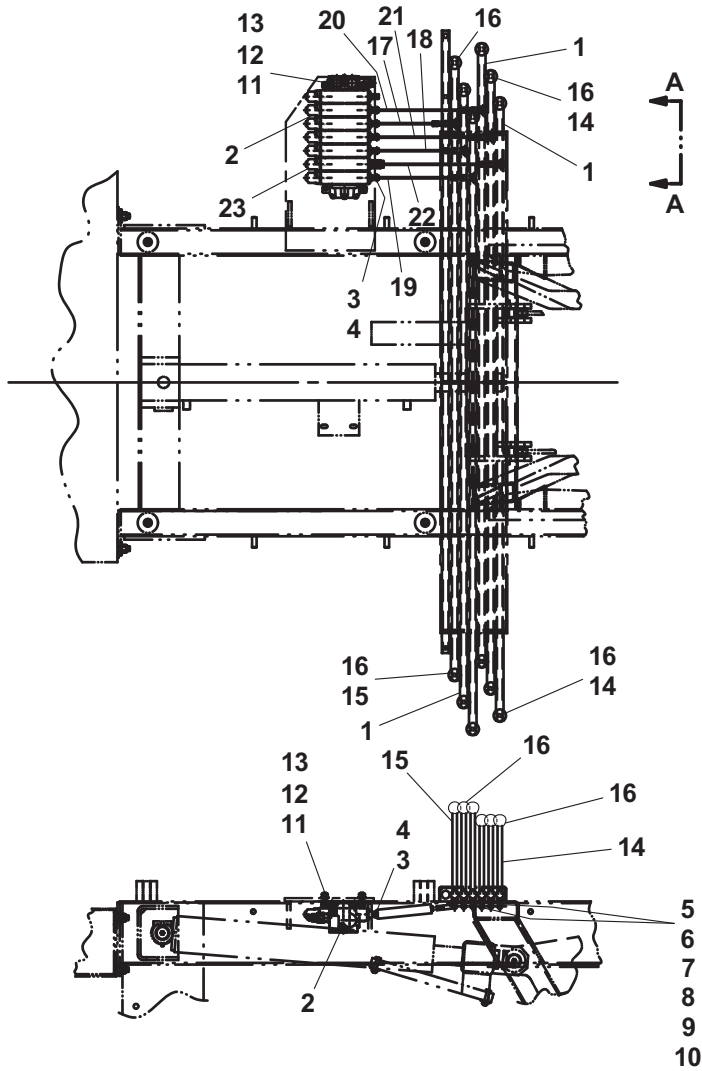

DUAL CONTROLS - 7 BANK

ITEM	PART NO.	DESCRIPTION	QTY	ITEM	PART NO.	DESCRIPTION	QTY
1	4763000154	Rod	7	23	3763000153	Rod Weld	1
2	7935000261	Control Valve	1	24	7115151050	Capscrew, 0.31"-18NC x 1.25" (with Remote Control Valve)	1
	3935000162	Control Valve (Remote Operation)					
3	7690101200	Clevis Pin	7				
4	7691000056	Cotter Hairpin	7				
5	7990000003	Yoke	7				
6	7690141200	Clevis Pin	7				
7	7690000810	Cotter Pin	7				
8	7660140230	Jam Nut, 0.25"-28NF	7				
9	7765000006	Rod End	7				
10	7660160000	Hex Nut, 0.38"-16NC	7				
11	7115161250	Capscrew, 0.38"-16NC x 1.50" (non Remote Control Valve)	3				
	7115161250	Capscrew, 0.38"-16NC x 1.50" (with Remote Control Valve)	2				
12	7950160252	Flatwasher, 0.38" ID (non Remote Control Valve)	3				
	7950160252	Flatwasher, 0.38" ID (with Remote Control Valve)	2				
13	7660162601	Locknut, 0.38"-16NC (non Remote Control Valve)	3				
	7660162601	Locknut, 0.38"-16NC (with Remote Control Valve)	2				
14	4763000150	Handle	6				
15	4763000151	Handle	8				
16	7551000002	Knob	14				
17	3763000154	Rod Weld	1				
18	3763000155	Rod Weld	1				
19	3763000156	Rod Weld	1				
20	3763000157	Rod Weld	1				
21	3763000158	Rod Weld	1				
22	3763000159	Rod Weld	1				

DUAL CONTROLS - 7 BANK

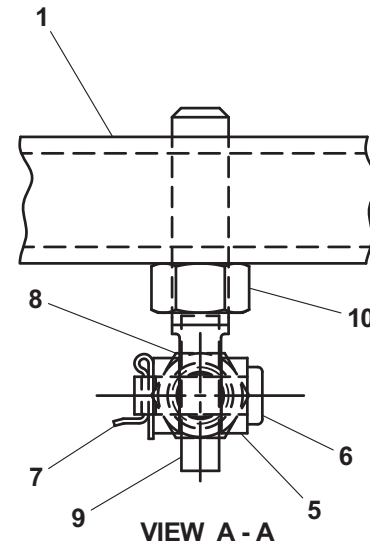
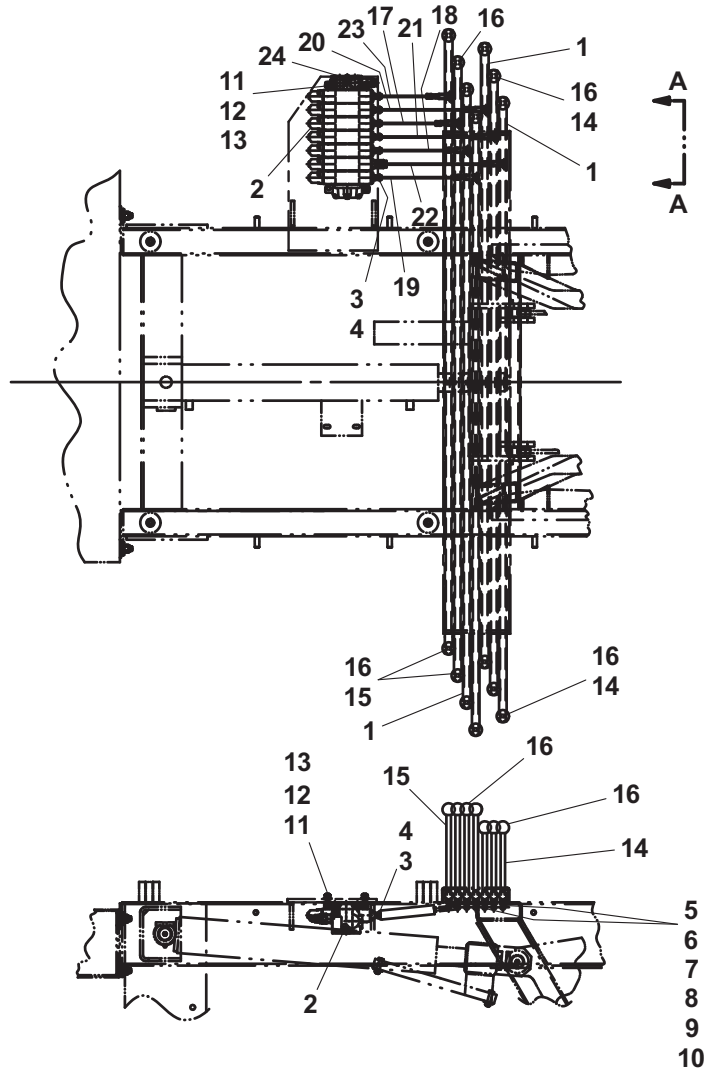

ELECTRICAL COMPONENTS - STANDARD LIGHTS AND WIRING

ITEM	PART NO.	DESCRIPTION	QTY	ITEM	PART NO.	DESCRIPTION	QTY
1	7552000234	Cab to Body Harness	1	25	7590000193	ID Marker Light - Red (INC)	1
2	7457000004	Circuit Breaker	1		7590000316	ID Marker Light - Red (LED)	
3	7345231901	Terminal	1	26	7114141018	Capscrew, 0.25"-20NC x 1.25"	2
4	7345211901	Terminal	2	27	7950140143	Flatwasher, 0.25" ID	2
5	7790100856	Screw, #10 x 0.50"	2	28	7660142604	Locknut, 0.25"-20NC	2
6	7552000235	Body Harness - 60" Body	1	30	See Note 1	Tail Light	2
	7552000236	Body Harness - 84" Body		31	7552000237	Cross-Over Tbx Extension Harness (24")	1
7	7590000047	Marker Light - Red (INC)	4		7552000025	Cross-Over Tbx Extension Harness (48")	
	7590000343	Marker Light - Red (LED)		32	7120000072	Capscrew, #10-24NC x 1.25"	12
8	7493000009	Grommet	6	33	7950100153	Flatwasher, #10 ID	12
9	7590000048	Marker Light - Amber (INC)	2	34	7660102604	Locknut, #10-24NC	12
	7590000342	Marker Light - Amber (LED)		35	7577000194	Chassis Connector Kit	1
10	7590000002	Stop, Turn, Tail Light - Red (INC)	2	36	7111141050	Capscrew, 0.25"-20NC x 1.25"	1
	7590000241	Stop, Turn, Tail Light - Red (LED)		37	7950140141	Flatwasher, 0.25" ID	2
11	7590000003	Back-Up Light - White	2	38	7660142600	Locknut, 0.25"-20NC	1
12	7259000004	Tail Light Housing	4				
13	7796000076	Gasket	4				
14	7493000003	Grommet	1				
15		Not Required					
16	7291000010	4-Way Receptacle	1				
17	7796000096	Gasket	1				
18	7111140613	Capscrew, 0.25"-20NC x 0.75"	2				
19	7950140000	Lockwasher, 0.25" ID	2				
20	7413000002	Nutsert, 0.25"-20NC	2				
21	7590000001	Interior Light (left side toolbox)	1				
	7590000001	Interior Light (left & right toolbox)	2				
22	7790060676	Screw, #6 x 0.38"	3				
23	7345221704	Terminal	9				
24	7552000238	Cab to Headboard Harness (pylon)	1				
	7552000239	Cab to Headboard Harness (cross-over toolbox & headboard)					

Note 1: Varies depending on chassis. Consult OEM for part number.

ELECTRICAL COMPONENTS - STANDARD LIGHTS AND WIRING

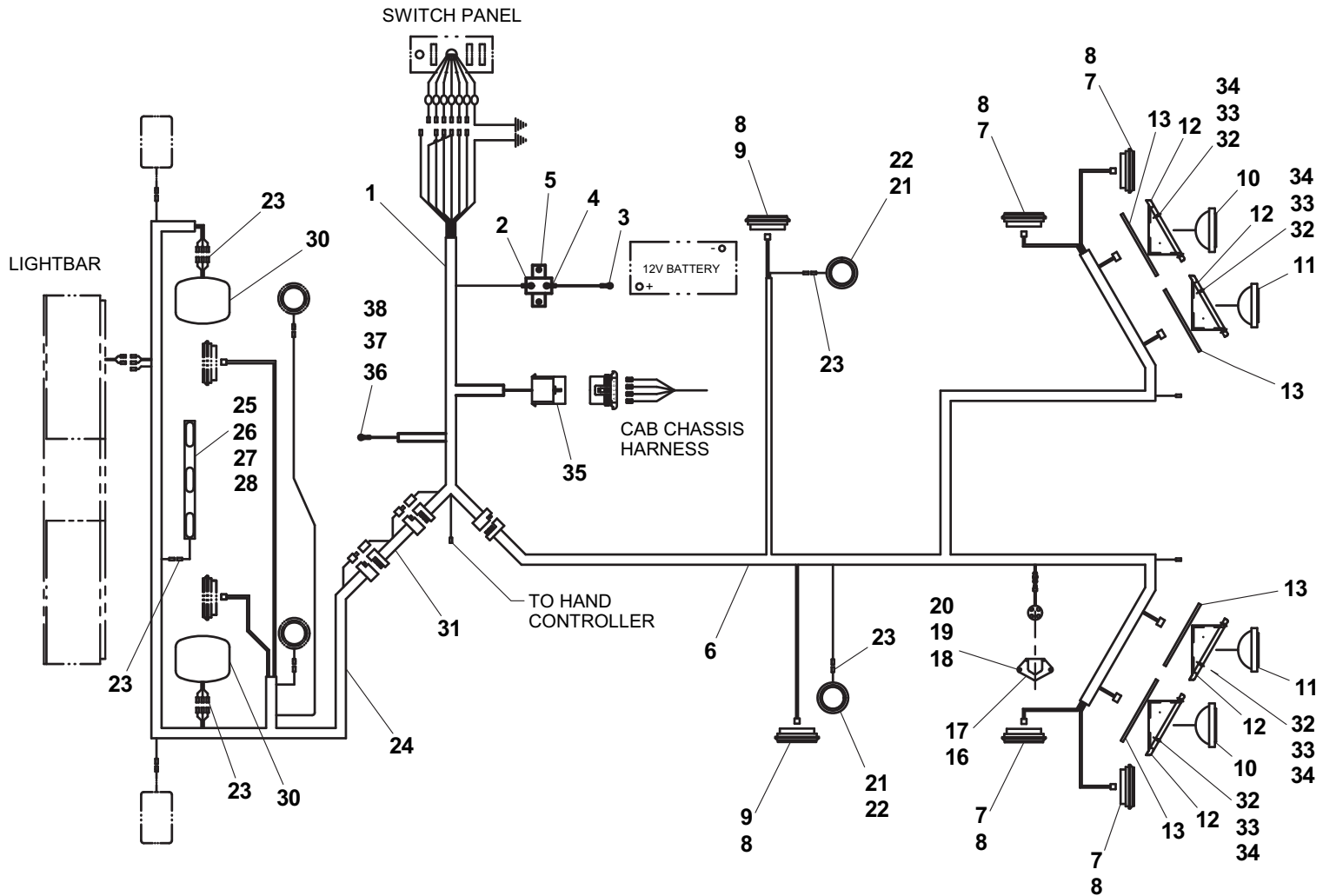

Item #14, Grommet not shown

ELECTRICAL COMPONENTS - OPTIONAL LIGHTS AND WIRING

ITEM	PART NO.	DESCRIPTION	QTY
1	7590000048	Marker Light - Amber	2
2	7493000009	Grommet	2
3	7590000001	Interior Light (cross-over toolbox)	2
4	7790060676	Screw, #6 x 0.38" (cross-over toolbox)	6
5	7345001704	Terminal (cross-over toolbox)	2
6	7590000008	Worklight	2
7	4178000015	Bracket	2
8	7114140818	Capscrew, 0.25"-20NC x 1.00"	4
9	7950140161	Flatwasher, 0.25" ID	4
11	7345001930	Terminal	2
12	7590000011	Work Light	2

ELECTRICAL COMPONENTS - OPTIONAL LIGHTS AND WIRING

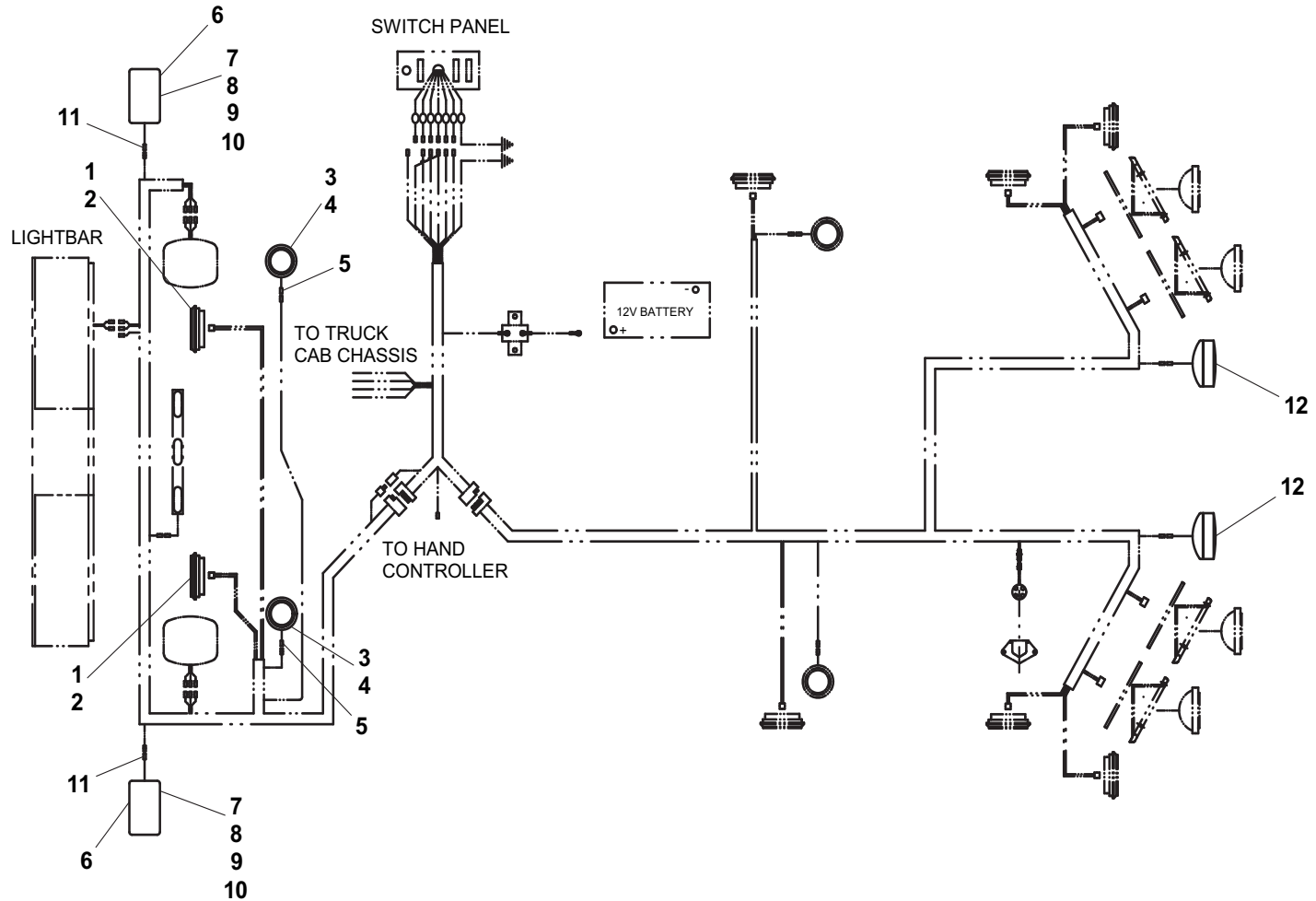

ELECTRICAL COMPONENTS - TAIL LIGHT CONVERTER

ITEM	PART NO.	DESCRIPTION	QTY
1	7297000008	Tail Light Converter	1
2	4706002990	Plate	1
3	7661000007	Wellnut, #10-32NF	4
4	7104100613	Capscrew, #10-32NF x 0.75"	4
5	7790151253	Screw, 0.31"-18NC x 0.75"	2
6	7345001714	Terminal	5
7	4346000005	Heat Shrink Tubing - 1.50"	5
8	7345221902	Terminal	1
9	7345241902	Terminal	1
10	7346000126	Fuse Holder	1
11	7457000017	Fuse - 30 amp	1
12	7345001914	Terminal	1
13	7346000209	Resistor (UD chassis w/ Incandes't lights)	1
14	7346000220	Resistor (UD chassis w/ LED lights)	1

ELECTRICAL COMPONENTS - TAIL LIGHT CONVERTER

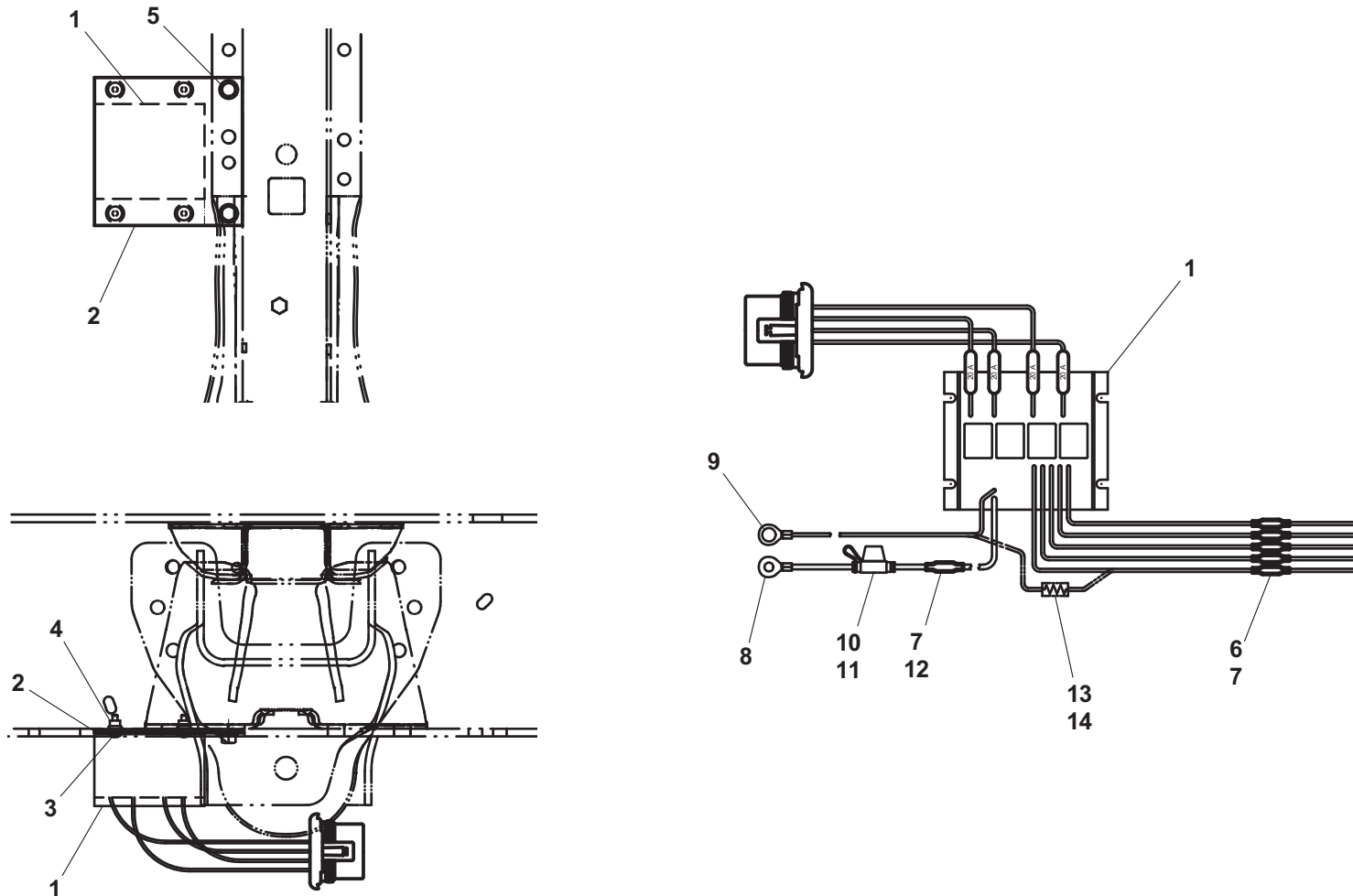

WHEEL LIFT BOOM ELEVATION CYLINDER ASSEMBLY - P/N 3320000228

ITEM	PART NO.	DESCRIPTION	QTY
1	3071000212	Barrel Weld	1
2	3763000186	Rod Weld	1
3	4698000009*	Piston	1
4	7796000013*	Wear Ring	2
5	7796000064*	Piston Locking "T" Seal	1
6	7755226609*	Back-Up Ring	2
7	7755226000*	"O" Ring	1
8	4553000010^	Head	1
9	7755338000^	"O" Ring	1
10	7755338609^	Back-Up Ring	1
11	7754000012^	Wear Ring	1
12	7796000025^	Rod Seal	1
13	7796000011^	Rod Wiper Seal	1
14	7754000016	Retaining Ring	1
15	7754000027	Retaining Ring	1
16	7661000035	Locknut	1

* included in Piston Assembly, P/N 3698000004

+ included in Head Assembly, P/N 3553000014

WHEEL LIFT BOOM ELEVATION CYLINDER ASSEMBLY - P/N 3320000228

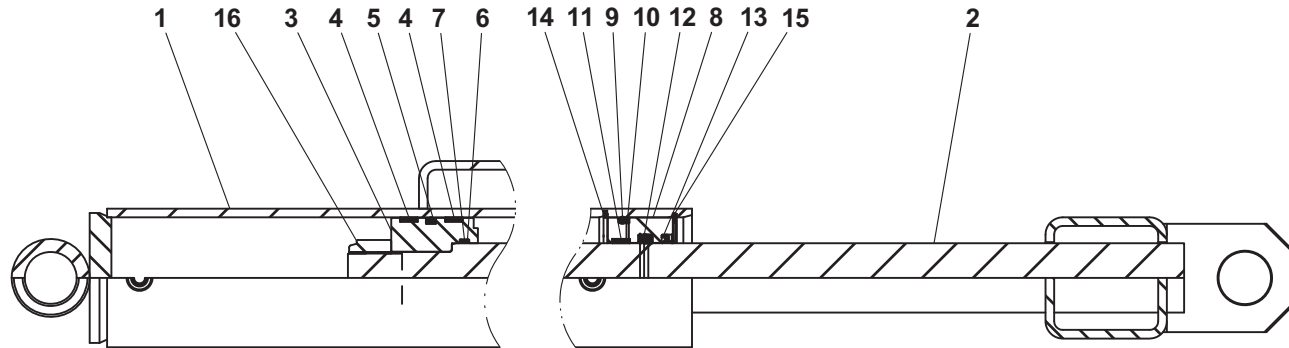

WHEEL LIFT BOOM TILT CYLINDER ASSEMBLY - P/N 3320000016

ITEM	PART NO.	DESCRIPTION	QTY
1	3071000017	Barrel Weld	1
2	3763000043	Rod Weld	1
3	4698000008*	Piston	1
4	7754000011*	Wear Ring	2
5	7796000065*	Piston Locking "T" Seal	1
6	7755226609*	Back-Up Ring	2
7	7755226000*	"O" Ring	1
8	4553000009^	Head	1
9	7755342000^	"O" Ring	1
10	7755342609^	Back-Up Ring	1
11	7754000012^	Wear Ring	1
12	7796000025^	Rod Seal	1
13	7796000011^	Rod Wiper Seal	1
14	7754000028	Retaining Ring	1
15	7661000035	Locknut	1

* included in Piston Assembly, P/N 3698000002

+ included in Head Assembly, P/N 3553000012

WHEEL LIFT BOOM TILT CYLINDER ASSEMBLY - P/N 3320000016

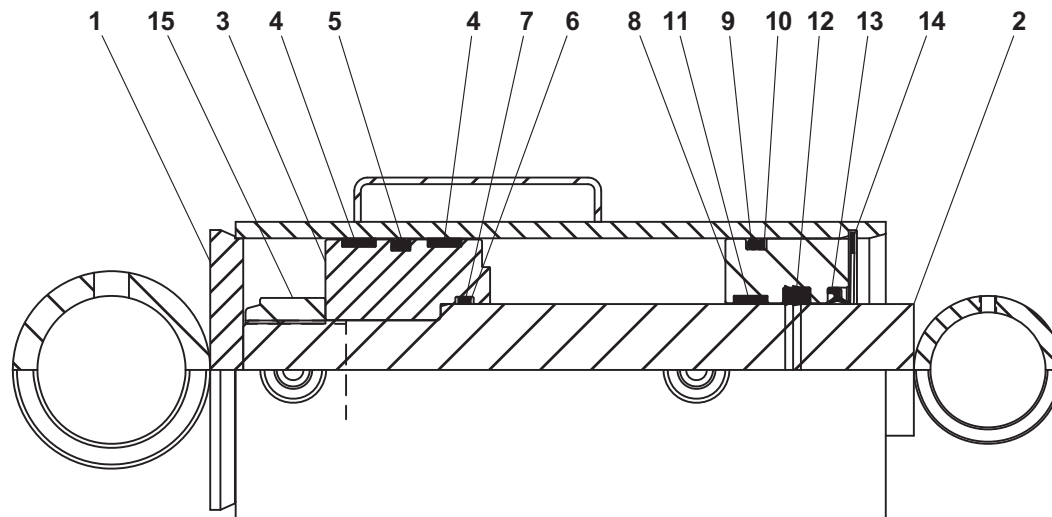

WRECKER BOOM TILT CYLINDER ASSEMBLY - 4 TON - P/N 3320000044

ITEM	PART NO.	DESCRIPTION	QTY
1	3071000042	Barrel Weld	1
2	3763000056	Rod Weld	1
3	4698000008*	Piston	1
4	7754000011*	Wear Ring	2
5	7796000065*	Piston Locking "T" Seal	1
6	7755226609*	Back-Up Ring	2
7	7755226000*	"O" Ring	1
8	4553000009^	Head	1
9	7755342000^	"O" Ring	1
10	7755342609^	Back-Up Ring	1
11	7754000012^	Wear Ring	1
12	7796000025^	Rod Seal	1
13	7796000011^	Rod Wiper Seal	1
14	7754000013	Retaining Ring	1
15	7754000028	Retaining Ring	1
16	7661000035	Locknut	1

* included in Piston Assembly, P/N 3698000002

+ included in Head Assembly, P/N 3553000012

WRECKER BOOM TILT CYLINDER ASSEMBLY - 4 TON - P/N 3320000044

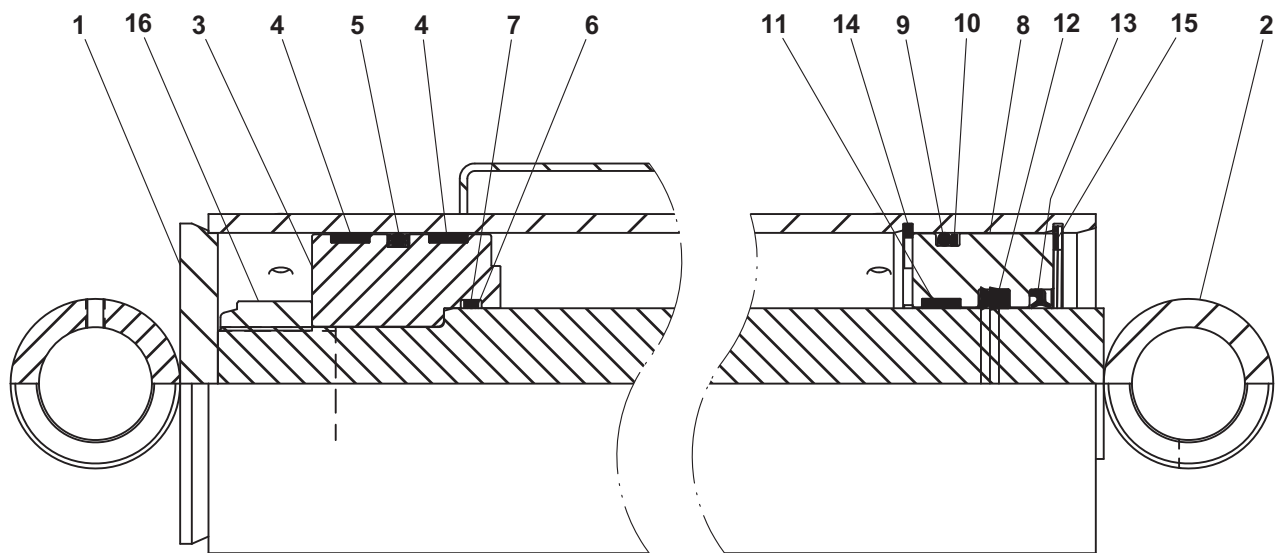

WRECKER BOOM EXTENSION CYLINDER ASSEMBLY - 4 TON - P/N 3320000045

ITEM	PART NO.	DESCRIPTION	QTY
1	3071000043	Barrel Weld	1
2	3763000057	Rod Weld	1
3	4698000011*	Piston	1
4	7754000030*	Wear Ring	2
5	7796000062*	Piston Locking "T" Seal	1
6	7755214609*	Back-Up Ring	2
7	7755214000*	"O" Ring	1
8	4831000117	Spacer	1
9	4553000015^	Head	1
10	7755327000^	"O" Ring	1
11	7755327609^	Back-Up Ring	1
12	7754000036^	Wear Ring	1
13	7796000023^	Rod Seal	1
14	7796000005^	Rod Wiper Seal	1
15	7754000001	Retaining Ring	2
16	7661000037	Locknut	1

* included in Piston Assembly, P/N 3698000005

+ included in Head Assembly, P/N 3553000015

WRECKER BOOM EXTENSION CYLINDER ASSEMBLY - 4 TON - P/N 3320000045

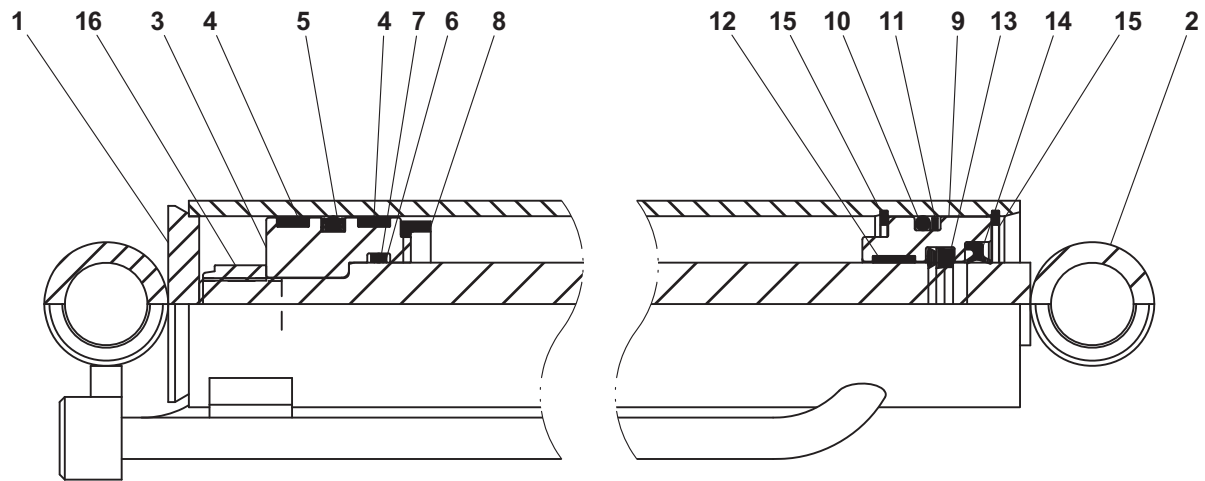

WRECKER BOOM TILT CYLINDER ASSEMBLY - 8/12 TON - P/N 3320000011 & 3320000012

ITEM	PART NO.	DESCRIPTION	QTY
1	3071000011	Barrel Weld (Assembly P/N 3320000011)	1
	3071000012	Barrel Weld (Assembly P/N 3320000012)	
2	3763000041	Rod Weld	1
3	4698000008*	Piston	1
4	7754000011*	Wear Ring	2
5	7796000065*	Piston Locking "T" Seal	1
6	7755226609*	Back-Up Ring	2
7	7755226000*	"O" Ring	1
8	4553000009^	Head	1
9	7755342000^	"O" Ring	1
10	7755342609^	Back-Up Ring	1
11	7754000012^	Wear Ring	1
12	7796000025^	Rod Seal	1
13	7796000011^	Rod Wiper Seal	1
14	7754000013	Retaining Ring	1
15	7754000028	Retaining Ring	1
16	7661000035	Locknut	1

* included in Piston Assembly, P/N 3698000002

+ included in Head Assembly, P/N 3553000012

WRECKER BOOM TILT CYLINDER ASSEMBLY - 8/12 TON - P/N 3320000011 & 3320000012

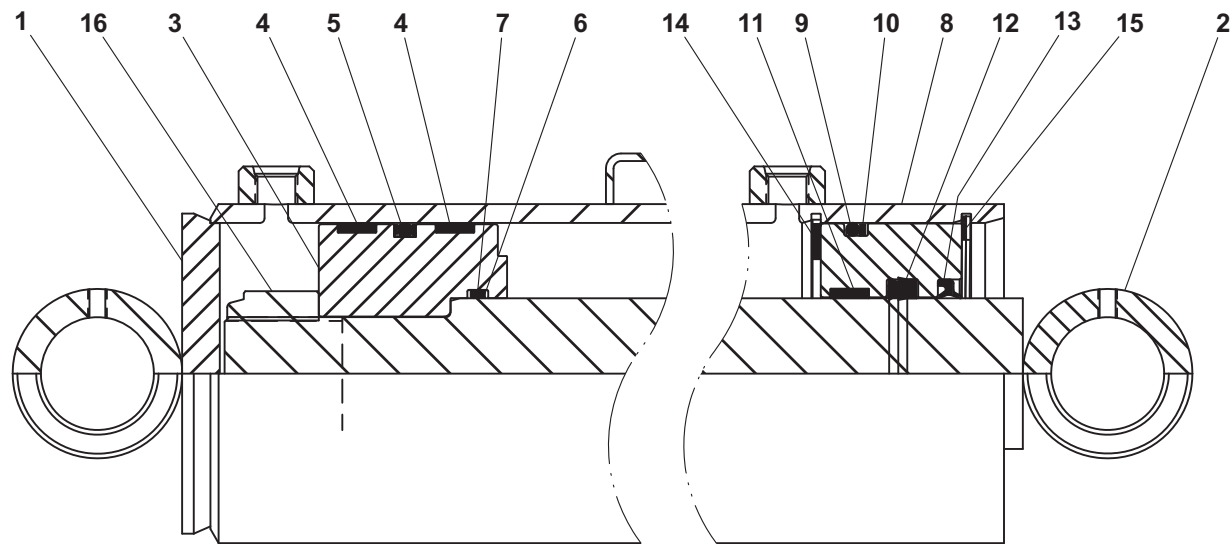

WRECKER BOOM EXTENSION CYLINDER ASSEMBLY - 8/12 TON - P/N 332000007

ITEM	PART NO.	DESCRIPTION	QTY
1	3071000007	Barrel Weld	1
2	3763000040	Rod Weld	1
3	4698000007*	Piston	1
4	7754000003*	Wear Ring	2
5	7796000063*	Piston Locking "T" Seal	1
6	7755224609*	Back-Up Ring	2
7	7755224000*	"O" Ring	1
8	4553000008^	Head	1
9	7755334000^	"O" Ring	1
10	7755334609^	Back-Up Ring	1
11	7754000004^	Wear Ring	1
12	7796000024^	Rod Seal	1
13	7796000008^	Rod Wiper Seal	1
14	7754000002	Retaining Ring	1
15	7754000026	Retaining Ring	1
16	7661000034	Locknut	1

* included in Piston Assembly, P/N 3698000001

+ included in Head Assembly, P/N 3553000011

WRECKER BOOM EXTENSION CYLINDER ASSEMBLY - 8/12 TON - P/N 332000007

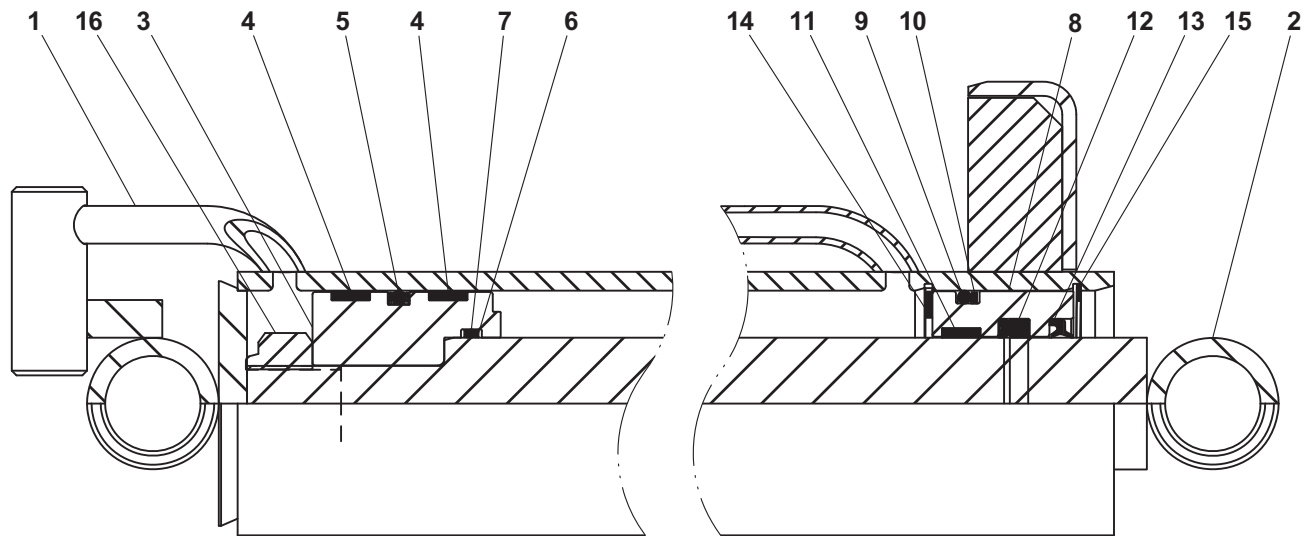

REMOTE CONTROL OPERATION

ITEM	PART NO.	DESCRIPTION	QTY
1	7295000105	Hand Controller	1
2	7552000329	Remote to Subframe Harness	1
3	7114080618	Capscrew, #8-32NC x 0.75"	2
4	7660082604	Locknut, #8-32NC	2
5	4706003402	Plate	2
6	7346000068	Dust Cap	1
7	7346000139	Electrical Connector	1
8	8977010300	Wire, #16 Ga	24in
9	7345221702	Wire Terminal	1
10	7552000286	Remote to Cab Harness	1
11	7790100856	Screw, #10 x 0.50"	2

REMOTE CONTROL OPERATION

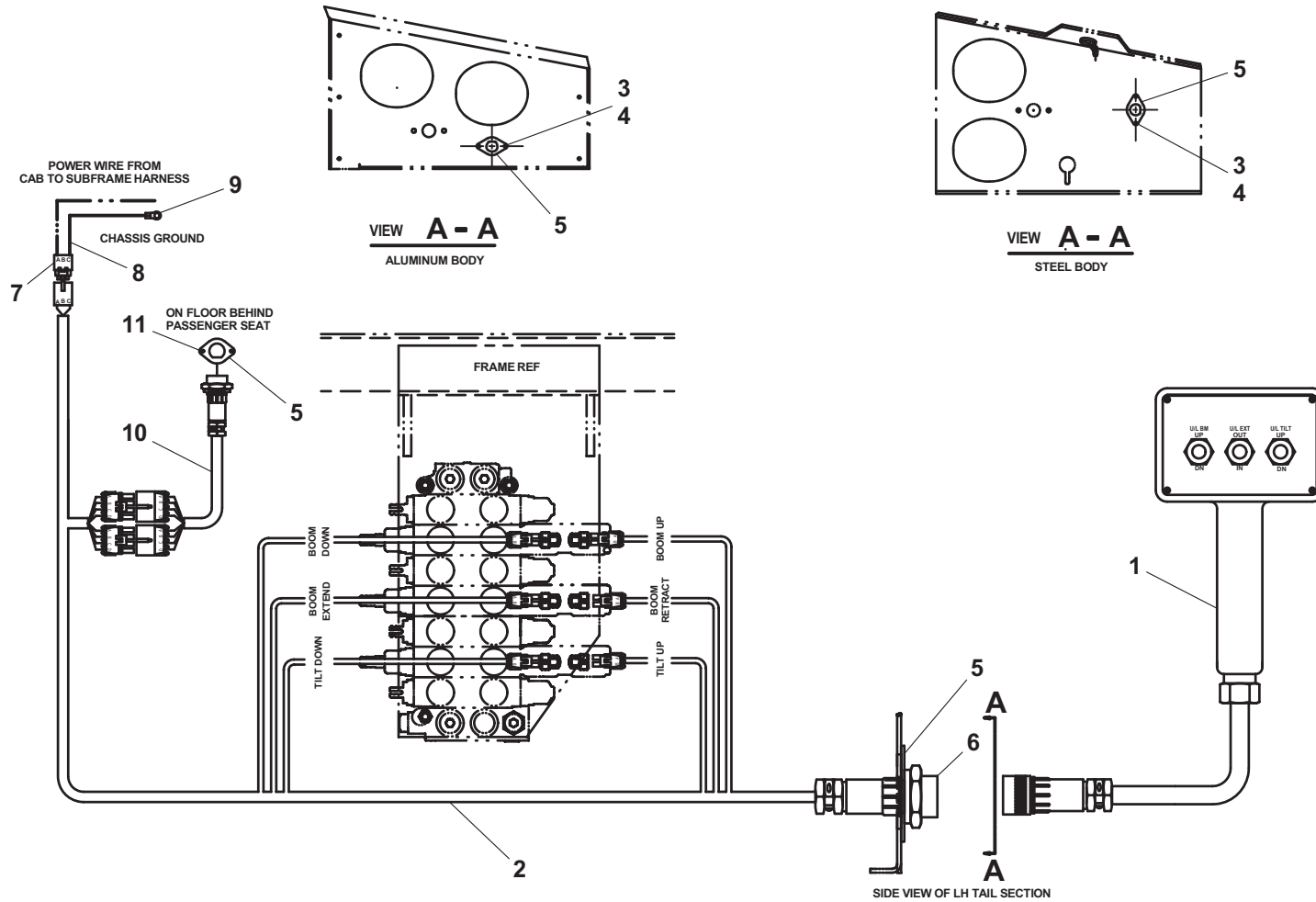

MUD FLAPS

ITEM	PART NO.	DESCRIPTION	QTY
1	4017000481	Angle (Ford & IHC / aluminum body)	1
	4017000478	Angle (GMC / aluminum body)	
	4017000494	Angle (Ford / steel body)	
	4017000492	Angle (GMC / steel body)	
	4017000496	Angle (IHC / steel body)	
2	4706001125	Plate (Ford & IHC / aluminum body) (Ford / steel body)	2
	4706001123	Plate (GMC / aluminum & steel body)	
	4706001124	Plate (Ford / steel body)	
3	4178000073	Bracket	2
4	7638000007	Mudflap (Ford & IHC / aluminum body) (IHC / steel body)	2
	7638000003	Mudflap (GMC / aluminum & steel body) (Ford / steel body)	
5	7111151010	Capscrew, 0.31"-18NC x 1.25"	8
6	7950150161	Flatwasher, 0.31" ID	14
7	7950150000	Lockwasher, 0.31" ID	14
8	7660150000	Hex Nut, 0.31"-18NC	14
9	7111150850	Capscrew, 0.31"-18NC x 1.00"	1
10	4017000481	Angle (Ford & IHC / aluminum body)	1
	4017000482	Angle (GMC / aluminum body)	
	4017000495	Angle (Ford / steel body)	
	4017000493	Angle (GMC / steel body)	
	4017000497	Angle (IHC / steel body)	

MUD FLAPS

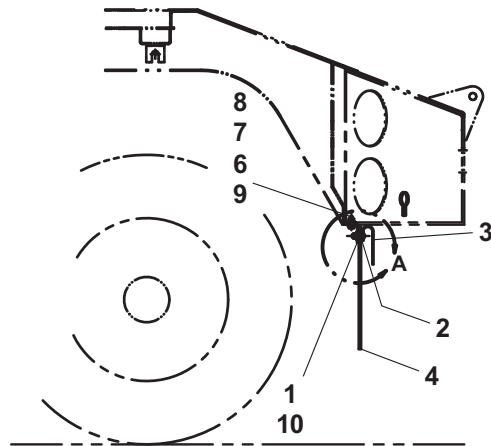

MUD FLAPS ON STEEL BODY

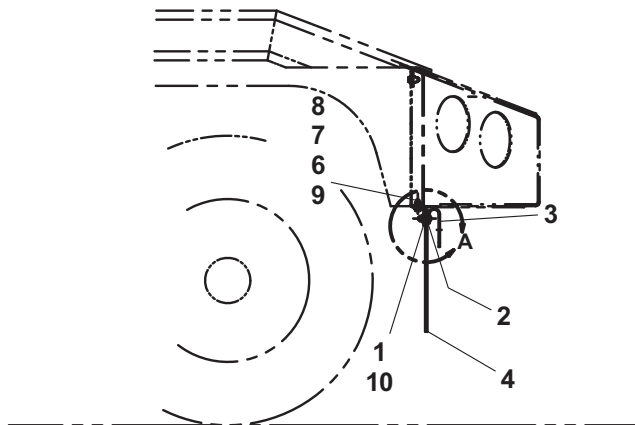
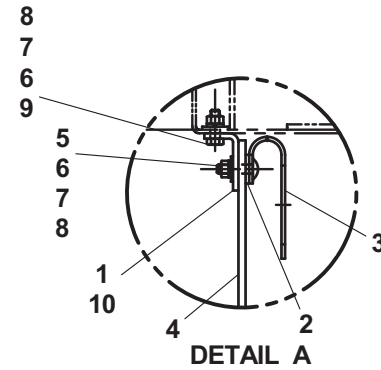

MUD FLAPS ON ALUMINUM BODY

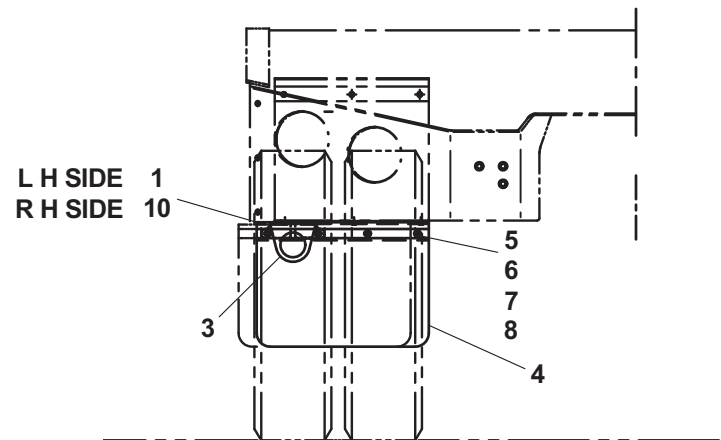

FENDER FLARES

ITEM	PART NO.	DESCRIPTION	QTY
1	7415000004	Fender Flare - 2.50" (both sides) (aluminum & steel body)	2
	7415000017	Fender Flare - 4.50" - LH (aluminum & steel body)	1
2	7415000018	Fender Flare - 4.50" - RH (aluminum & steel body)	1
3	7790100856	Screw, #10 x 0.50" (aluminum body) (2.50" Fender Flares)	18
	7790100856	Screw, #10 x 0.50" (steel body) (2.50" Fender Flares)	22
	7790141056	Screw, 0.25"-20NC x 0.63" (4.50" Fender Flares)	16
4	7950100151	Flatwasher, #10 ID (aluminum body) (2.50" Fender Flares)	18
	7950100151	Flatwasher, #10 ID (steel body) (2.50" Fender Flares)	22
	7950140141	Flatwasher, 0.25 ID (4.50" Fender Flares)	16
5	4706001262	Plate (steel body)(2.50" Fender Flares)	2

FENDER FLARES

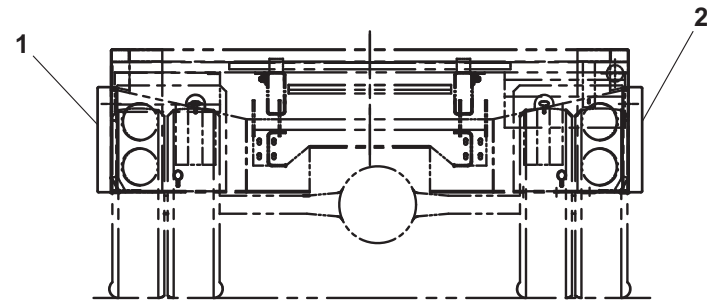
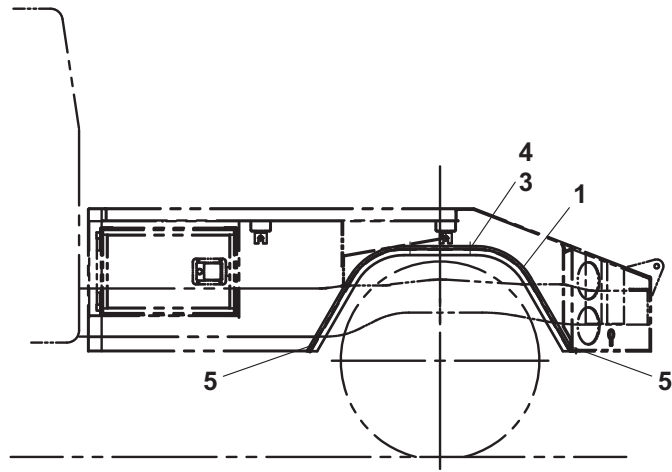

FLARES ON STEEL BODY

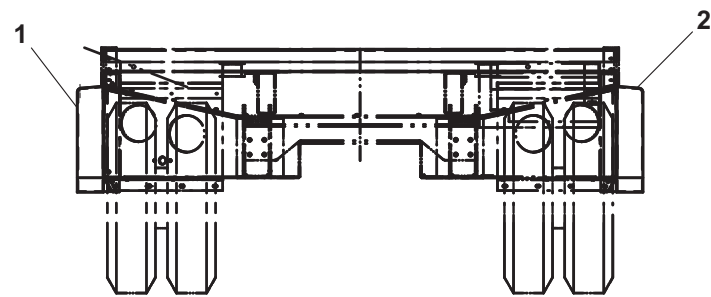
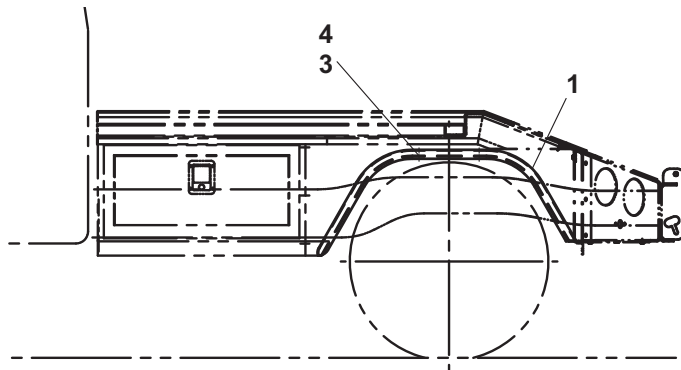

FLARES ON ALUMINUM BODY

HEADBOARD - BODY MOUNT

ITEM	PART NO.	DESCRIPTION	QTY
1	3241000038	Headboard Weld - 34" (aluminum body)	1
	3241000039	Headboard Weld - 37" (aluminum body)	
	3241000124	Headboard Weld - 40" (aluminum body)	
	3241000035	Headboard Weld - 34" (steel body)	
	3241000036	Headboard Weld - 40" (steel body)	
	3241000046	Headboard Weld - 50" (steel body)	
2	7796000047	Pad	2
3	7115181250	Capscrew, 0.50"-13NC x 1.50"	4
4	7950180161	Flatwasher, 0.50" ID	4
5	7950180000	Lockwasher, 0.50" ID	4
6	7660180006	Hex Nut, 0.50"-13NC	4

HEADBOARD - BODY MOUNT

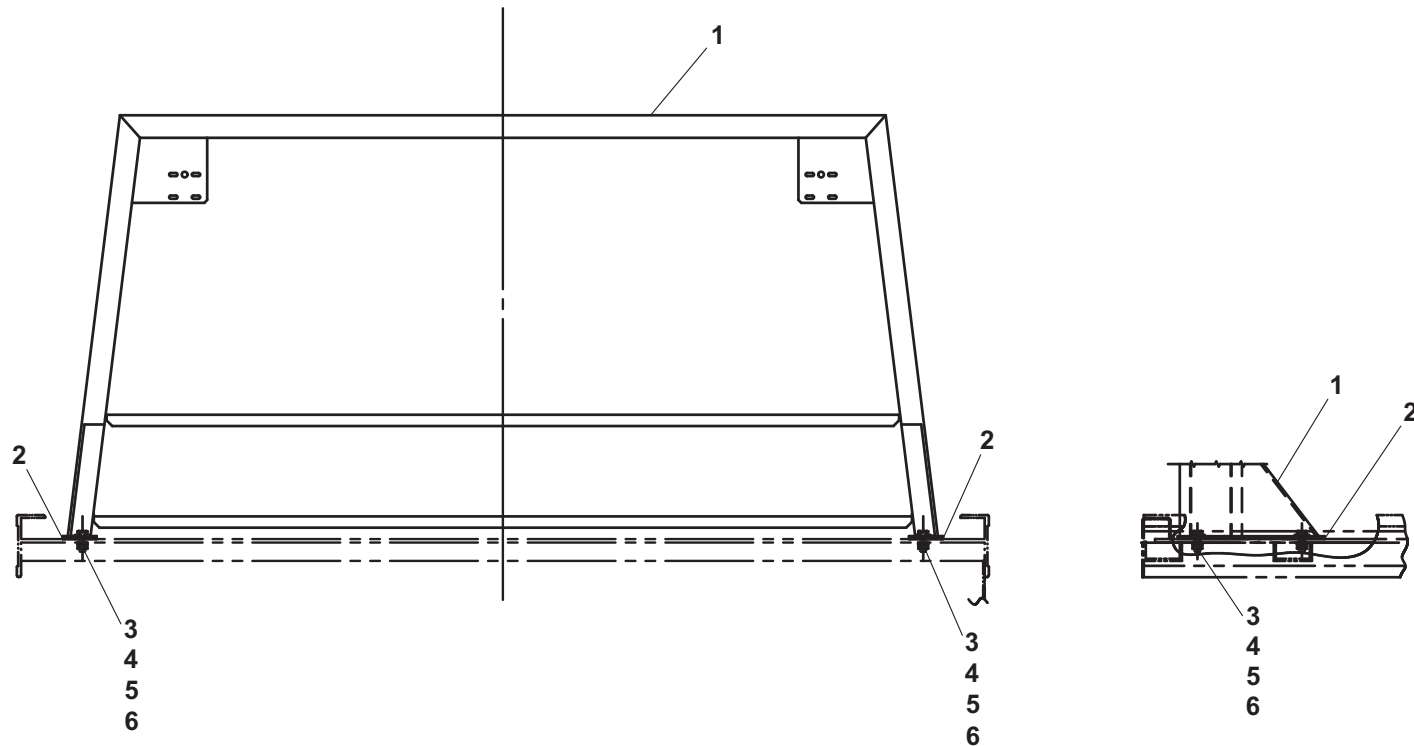

HEADBOARD - TOOLBOX MOUNT

ITEM	PART NO.	DESCRIPTION	QTY
1	324100037	Headboard Weld - 24" (aluminum body)	1
	3241000188	Headboard Weld - 27" (aluminum body)	
	3241000038	Headboard Weld - 34" (aluminum body)	
	3241000039	Headboard Weld - 37" (aluminum body)	
	3241000124	Headboard Weld - 40" (aluminum body)	
	3241000034	Headboard Weld - 24" (steel body)	
	3241000189	Headboard Weld - 27" (steel body)	
	3241000035	Headboard Weld - 34" (steel body)	
	3241000036	Headboard Weld - 40" (steel body)	
2	7796000047	Pad	2
3	7115181450	Capscrew, 0.50"-13NC x 1.75"	4
4	7950180161	Flatwasher, 0.50" ID	8
5	7660182601	Locknut, 0.50"-13NC	4

HEADBOARD - TOOLBOX MOUNT

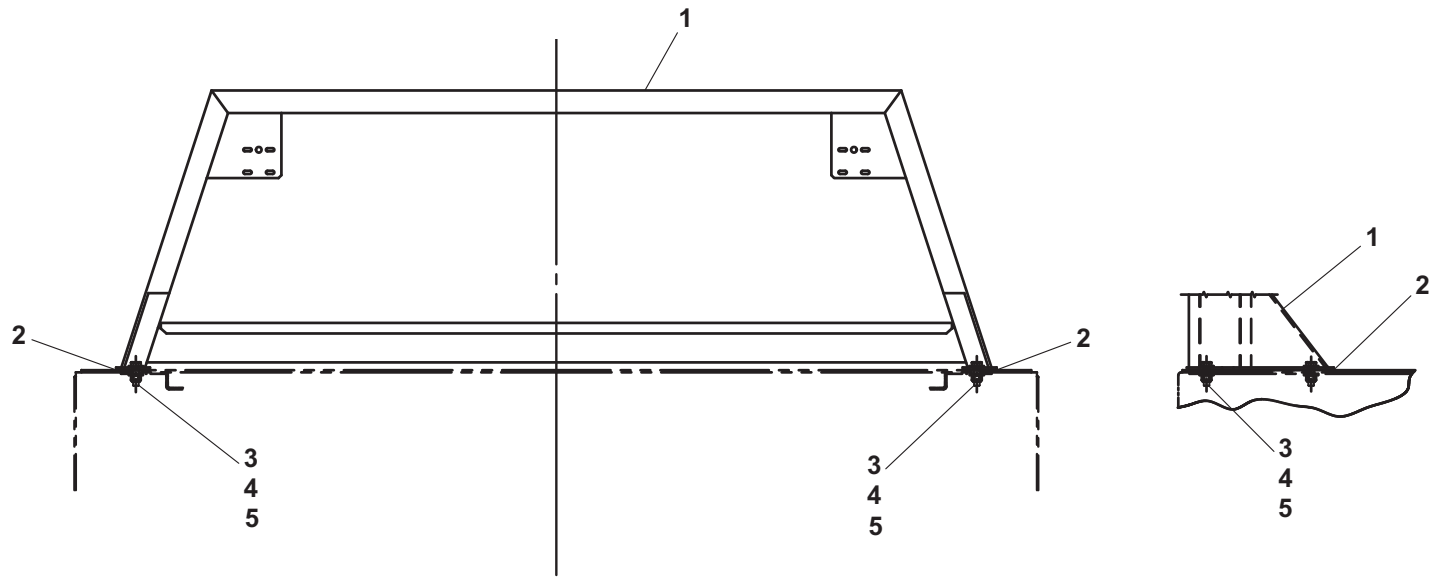

TOW SLING

ITEM	PART NO.	DESCRIPTION	QTY
1	3500800073	Sling Head Assembly	1
2	3020000007	Hold back Arm Assembly	2
3	3017000008	Anchor Weld	1
4	3309000007	U-Joint Weld	2
5	4706000727	Plate	1
6	4062000556	Bar	2
7	7679000010	Pad	2
8	7632045016	Moulding	1
9	7822000003	Sling Belt	2
10	7115223806	Shoulder Bolt, 0.63"-11NC x 4.75"	2
11	7804000001	Anchor Shackle (single winch)	1
	7804000001	Anchor Shackle (dual winch)	2
12	7105222650	Capscrew, 0.75"-16NF x 3.25"	2
13	7105223050	Capscrew, 0.75"-16NF x 3.75"	2
14	7661000017	Locknut, 0.75"-16NF	4
15	7115161250	Capscrew, 0.38"-16NC x 1.50"	6
16	7118163218	Capscrew, 0.38"-16NC x 4.00"	6
17	7660162601	Locknut, 0.38"-16NC	12
18	7440030000	Grease Fitting	7
19	7660202601	Locknut, 0.63"-11NC	2
20	7790101276	Screw, #10-24NC x 0.75"	4
21	7796000102	Seal, O-Ring	12

TOW SLING

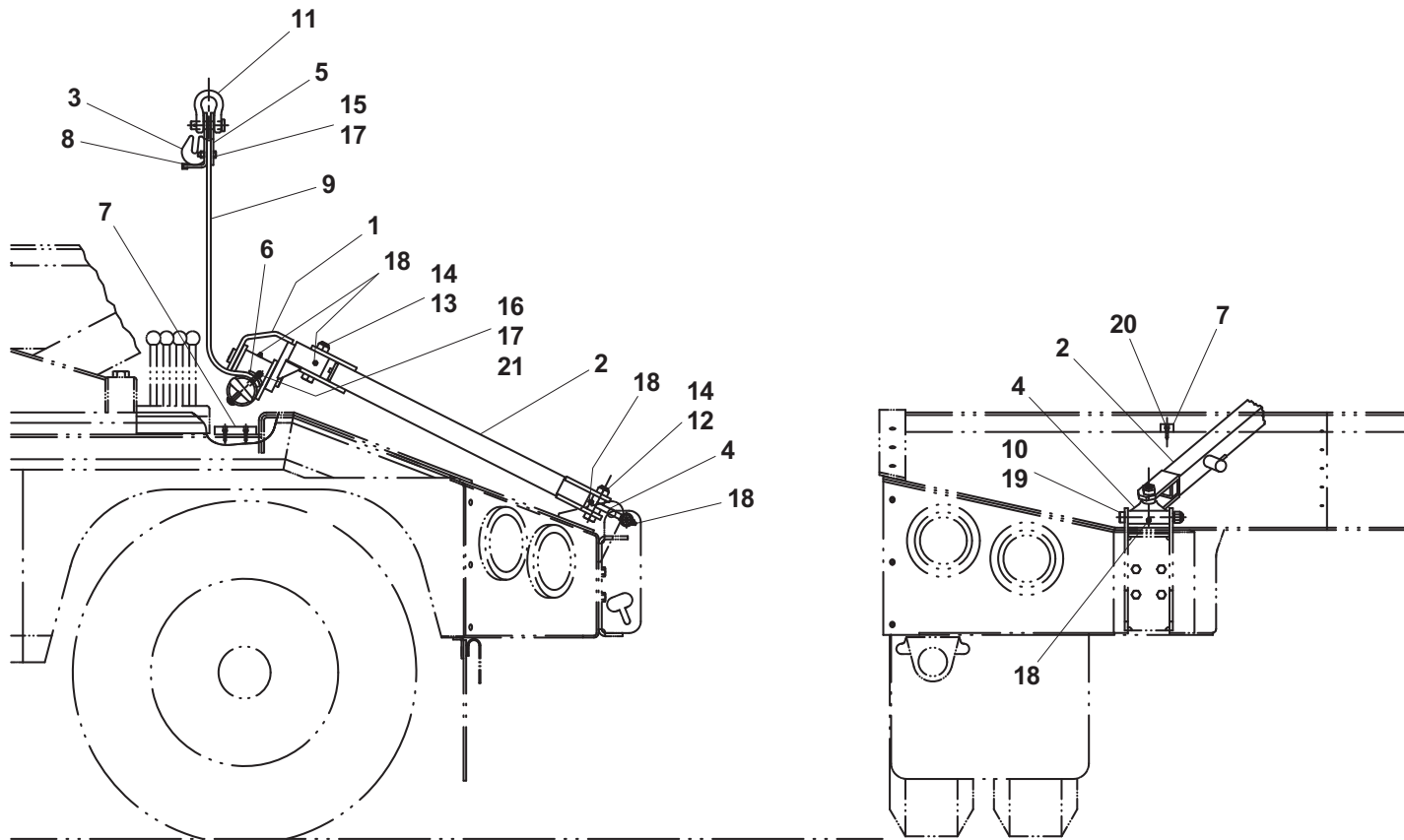

SELF-LOADING DOLLY

ITEM	PART NO.	DESCRIPTION	QTY
1	3178000033	Bracket Weld	2
2	3178000056	Bracket Weld	2
3	4178000215	Bracket	2
4	3002000001	Dolly Rework	1
5	7111161264	Carriage Bolt, 0.38"-16NC x 1.50"	2
6	7660162100	Wing Nut, 0.38"-16NC	2
7	7111161050	Capscrew, 0.38"-16NC x 1.25"	18
8	7950160000	Lockwasher, 0.38" ID	18
9	7413000003	Nutsert, 0.38"-16NC	18
10	7950160251	Flatwasher, 0.38" ID	2
11	7679000013	Pad	2
12	8632000002	Trim	9 in
13	7002000156	Hub Cap	4

SELF-LOADING DOLLY

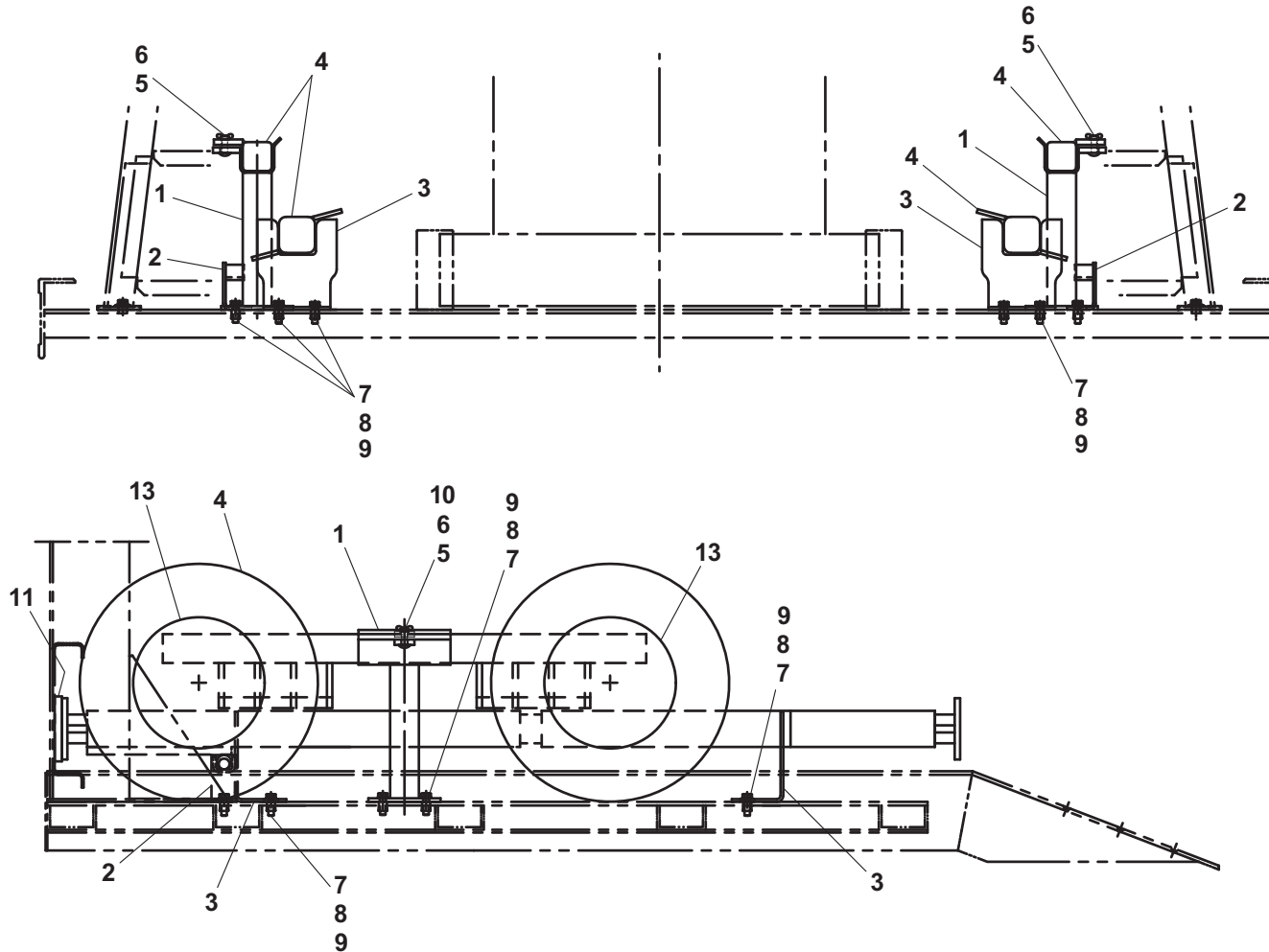

Item #12, Vinyl Trim, not shown

DECALS

ITEM	PART NO.	DESCRIPTION	QTY
1	7330000408	Jerr-Dan Nameplate	2
2	7330000145	Decal - Wrecker Boom	1
3	7330000717	Decal - Patent	1
4	7330000546	Decal - Cable Wrap Warning	2
	7330000546	Decal - Cable Wrap Warning (deck mounted winch)	1
5	7330000143	Decal - Made In The USA	1
6	7330000001	Serial Number Tag	2
7	7330000123	Decal - Lubrication	1
8	7330000124	Decal - Lubrication Chart (without Wrecker Boom or Deck Winch)	1
	7330000125	Decal - Lubrication Chart (with Deck Mounted Winch)	
	7330000126	Decal - Lubrication Chart (with Wrecker Boom)	
9	7330000034	Decal - Wheel Lift	1
10	7330000139	Decal - Checklist Reminder	1
11	4314000101	Coverplate	2
12	7330000540	Decal - Controls	2
13	7790141076	Screw, 0.25" x 0.63"	8
14	7330000088	Decal - "HPL" (red)	1
	7330000087	Decal - "HPL" (white)	
15	7330000122	Decal - Wheel Lift Polycarbonate	1
16	7330000683	Decal - Safety	2
17	7330000138	Decal - Pre-Transport Checklist	1
18	7330000384	Decal - Grid Service (T-37 Manual Grid)	2
19	7330000060	Decal - Hitch	1
20	7330000599	Decal - Moving Parts	1
21	7330000146	Decal - Wrecker "STAR"	1
22	7759000004	Pop Rivet	20
23	7330000419	Decal - Red Reflective	2
24	7330000420	Decal - Red Reflective - LH	1
	7330000432	Decal - Red Reflective - RH	1

DECALS

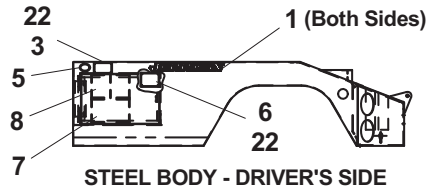

STEEL BODY - DRIVER'S SIDE

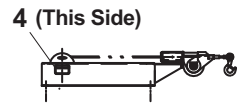

DECK MOUNTED WINCH STRUCTURE

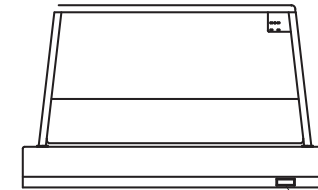

VIEW A - A

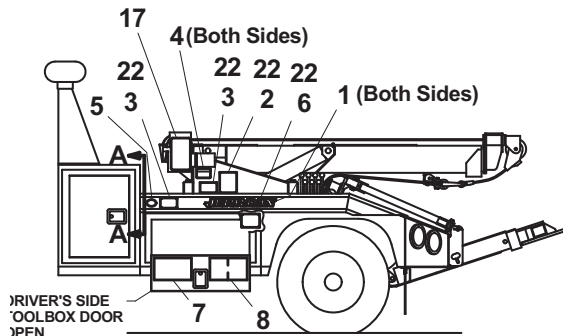

ALUMINUM BODY - DRIVER'S SIDE

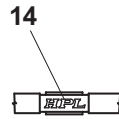

VIEW B - B

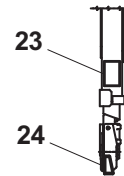

VIEW C - C

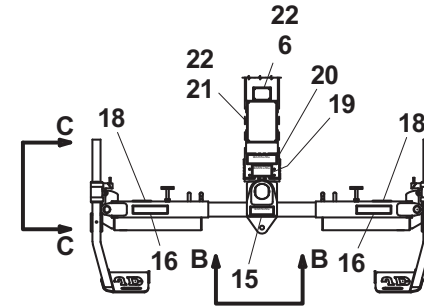

MANUAL T-37 WHEEL LIFT GRID

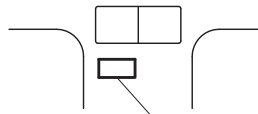

CAB DASHBOARD

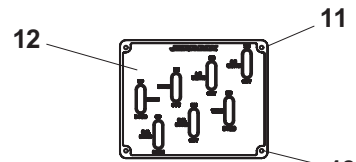

CONTROL HANDLE COVER PLATE & DECAL

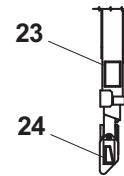

VIEW D - D

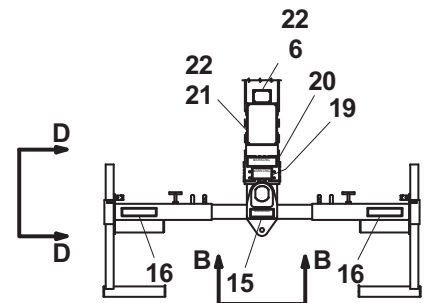

MANUAL L-ARM WHEEL LIFT GRID

FORKS AND ADAPTERS

ITEM	PART NO.	DESCRIPTION	QTY
1	7007000057	Low Fork Adapter - LH	1
2	7007000058	Low Fork Adapter - RH	1
3	3551000036	T-Handle	2
4	3512880013	High Fork Adapter Weld - LH	1
5	3512880012	High Fork Adapter Weld - RH	1
6	7454000007	Small Frame Fork	2
7	7454000008	Large Frame Fork	2
8	3512880016	Spring Hanger Fork	2
9	7691000017	Hitch Pin	2

FORKS AND ADAPTERS

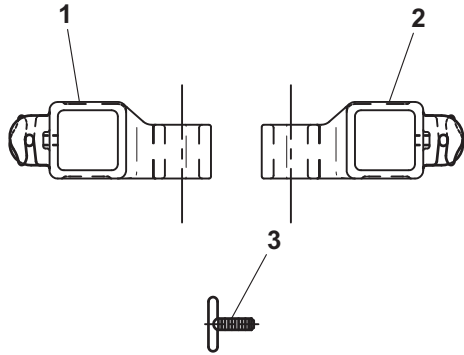

LOW FORK HOLDERS

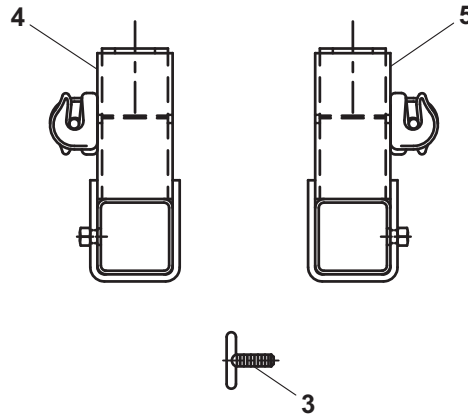

HIGH FORK HOLDERS

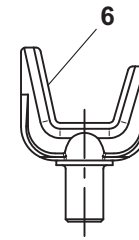

SMALL FRAME FORKS

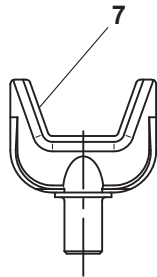

LARGE FRAME FORKS

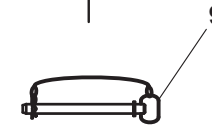
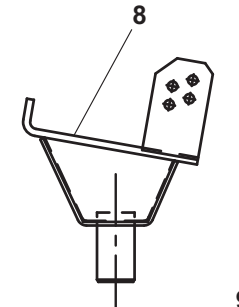

SPRING HANGER FORKS

SWITCH PANEL

ITEM	PART NO.	DESCRIPTION	QTY
1	7870000053	Switch Panel - 3 Function, Under Dash	1

SWITCH PANEL

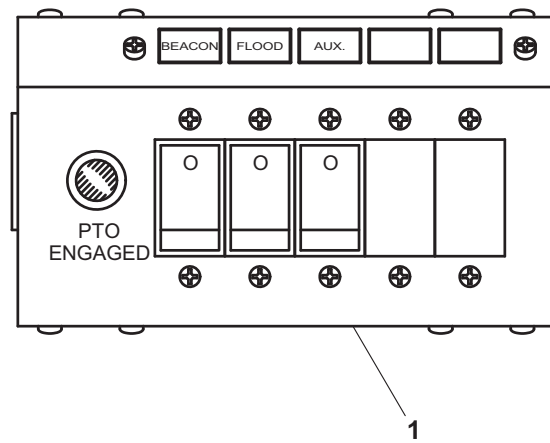

LIGHTBAR

ITEM	PART NO.	DESCRIPTION	QTY
1	7590000307	Lightbar, Amber (Std)	1
	7590000395	Lightbar, Amber (LED)	
	7590000336	Lightbar, Amber (Strobe)	
2	4178000402	Bracket Mount	2
3	7115181050	Capscrew, 0.50"-13NC x 1.25"	2
4	7660182601	Locknut, 0.50"-13NC	2

LIGHTBAR

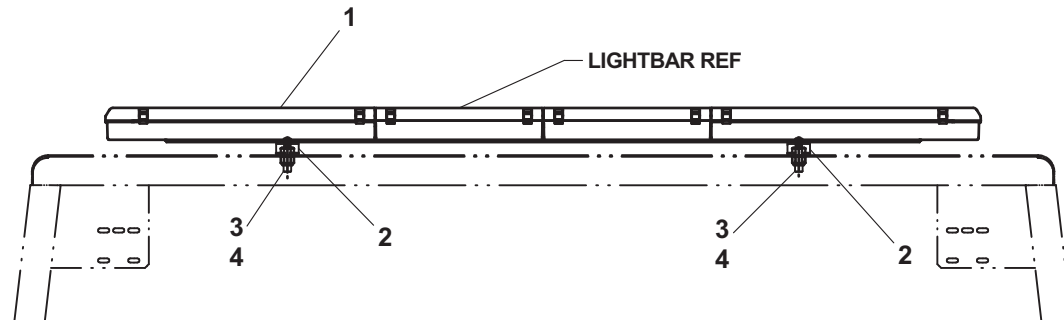
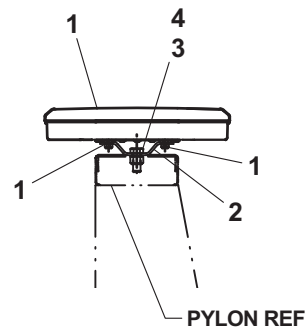

FOLD DOWN LIGHTBAR BRACKET

ITEM	PART NO.	DESCRIPTION	QTY
1	3178000443	Bottom Bracket Weld	2
2	4090000018	Belt	2
3	7115161250	Capscrew, 0.38"-16NC x 1.50"	8
4	7950160161	Flatwasher, 0.38" ID	8
5	7660162601	Locknut, 0.38"-16NC	8
6	3178000444	Top Bracket Weld	2
7	7585000001	Draw Latch	2
8	7114100518	Capscrew, #10-24NC x 0.62"	4
9	7950100103	Flatwasher, #10 ID	4
10	7660102604	Locknut, #10-24NC	4
11	7690144800	Clevis Pin	2
12	7690000810	Cotter Pin	2
13	4178000402	Bracket Mount	4
14	7115180950	Capscrew, 0.50"-13NC x 1.12"	4
15	7660182601	Locknut, 0.50"-13NC	4
16	7950180150	Flatwasher, 0.50" ID	4
17	4831000120	Spacer (Aluminum Headboard)	2
18	7115150664	Carriage Bolt, 0.31"-18NC x 0.75"	4
19	7660152601	Locknut, 0.31"-18NC	4

FOLD DOWN LIGHTBAR BRACKET

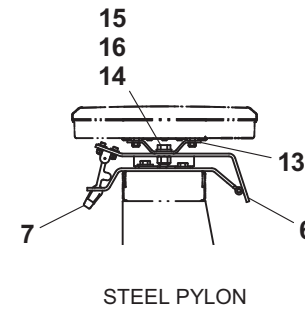
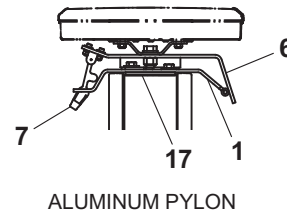
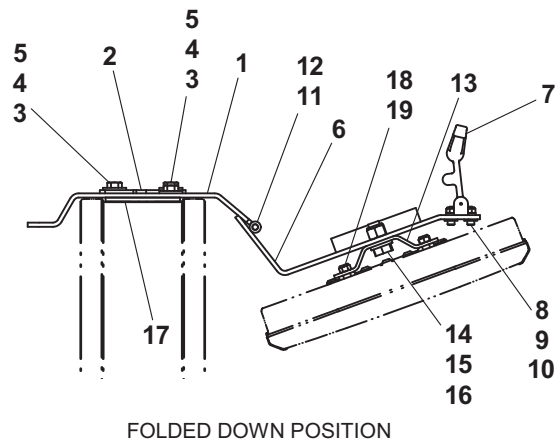
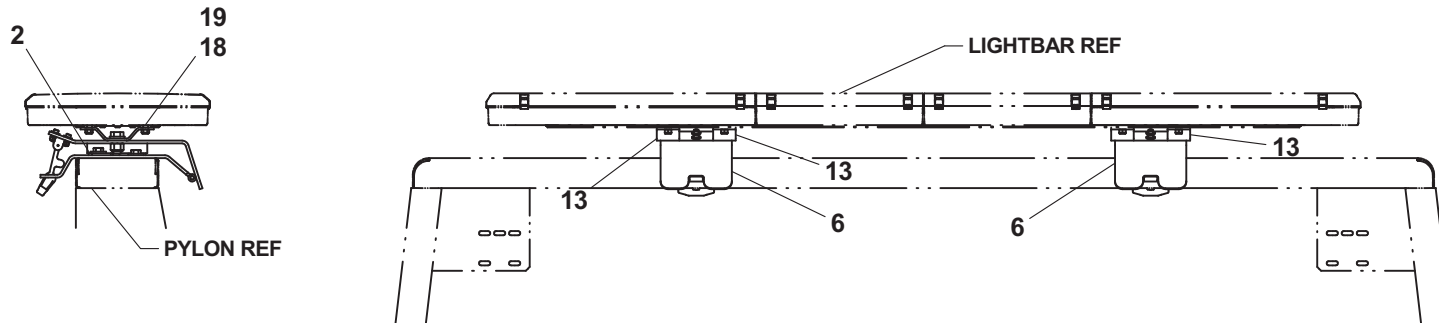

CHAIN AND STRAPS

ITEM	PART NO.	DESCRIPTION	QTY
1	7894000034	Wheel Lift Tire Strap	2
2	7262000010	Towbar Chain	2
3	7262000040	Wheel Lift Chain	2
4	7115171050	Capscrew, 0.44"-14NC x 1.25"	2
5	7660172600	Locknut, 0.44"-14NC	2
6	4314000030	Cover Plate - LH (steel body)	1
7	4314000029	Cover Plate - RH (steel body)	1
8	7759000007	Drive Rivet (steel body)	8
9	7894000024	Wheel Lift Fork Strap	2

CHAIN AND STRAPS

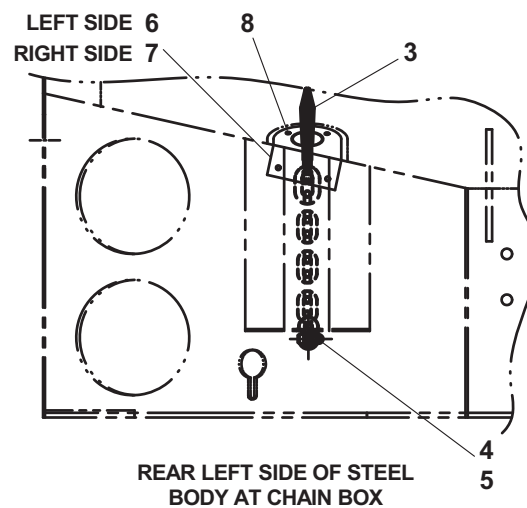
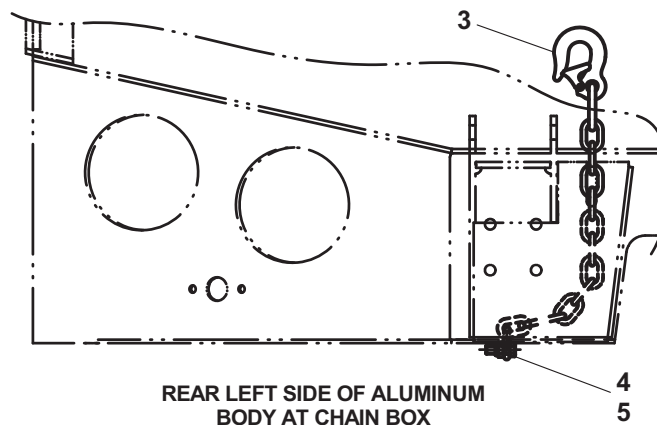
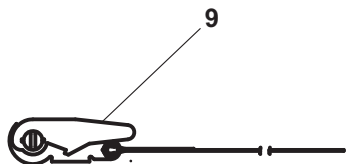
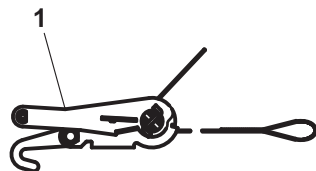

JUMP START KIT

ITEM	PART NO.	DESCRIPTION	QTY
1	7002000386	Jump Start Plug (IHC)	1
	7002000385	Jump Start Plug (Ford & Chevy)	
2	4178000372	Bracket (Ford)	1
	4178000202	Bracket (Chevy)	
3	4178000203	Bracket (Chevy)	1
4	7110140605	Capscrew, 0.25"-20NC x 0.75" (Ford & Chevy)	1
5	7950140161	Flatwasher, 0.25" ID (Ford)	1
	7950140161	Flatwasher, 0.25" ID (IHC)	2
	7950140161	Flatwasher, 0.25" ID (Chevy)	3
6	7660142600	Locknut, 0.25"-20NC (Ford & Chevy)	1
	7660142600	Locknut, 0.25"-20NC (IHC)	2
7	7115141450	Capscrew, 0.25"-20NC x 1.75" (IHC)	1
8	7115141650	Capscrew, 0.25"-20NC x 2.00" (IHC)	1
9	7660140000	Hex Nut, 0.25"-20NC (IHC)	1
	7660140000	Hex Nut, 0.25"-20NC (Chevy)	2
10	7111140850	Capscrew, 0.25"-20NC x 1.00" (Chevy)	2
11	7115181050	Capscrew, 0.50"-13NC x 1.25" (Chevy)	1
12	7950180153	Flatwasher, 0.50" ID (Chevy)	1
13	7660180000	Hex Nut, 0.50"-13NC (Chevy)	1

JUMP START KIT

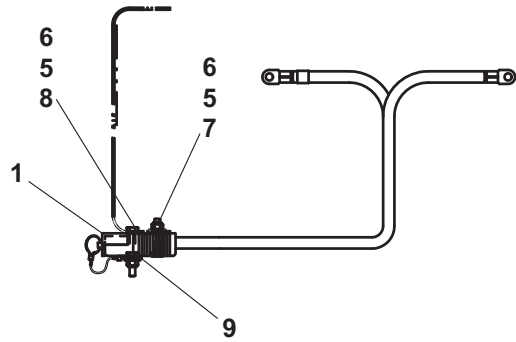

IHC FRONT BUMPER

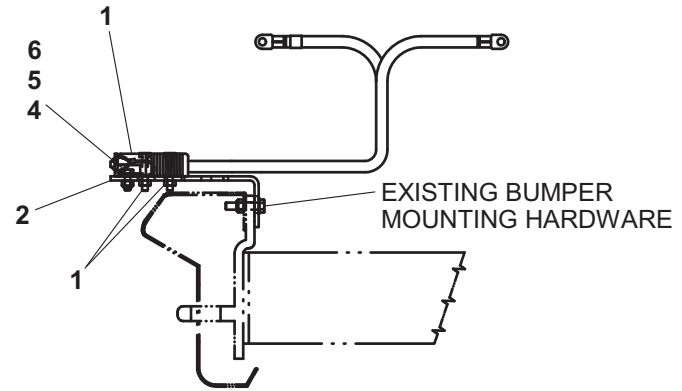

FORD FRONT BUMPER

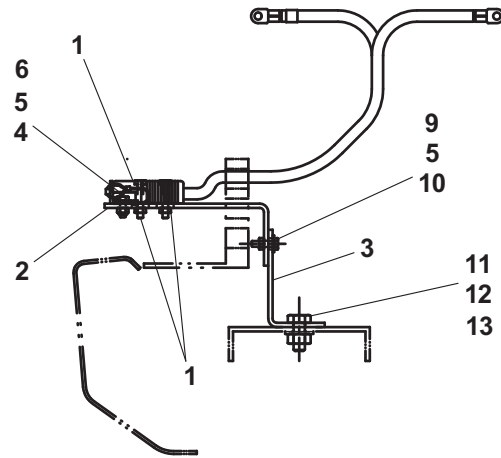

CHEVY FRONT BUMPER

WHEEL CHOCKS

ITEM	PART NO.	DESCRIPTION	QTY
1	7002000121	Wheel Chock (small)	2
	7002000120	Wheel Chock (large)	
2	3636000013	Mount Weld	2
	3636000012	Mount Weld	
3	4949000015	Washer, 0.38" ID	2
4	7660162100	Wing Nut, 0.38"-16NC	2
5	7413000003	Nutsert, 0.38"-16NC	8
6	7111161050	Capscrew, 0.38"-16NC x 1.25"	8
7	7950160000	Lockwasher, 0.38" ID	8
8	7950160161	Flatwasher, 0.38" ID	8

WHEEL CHOCKS

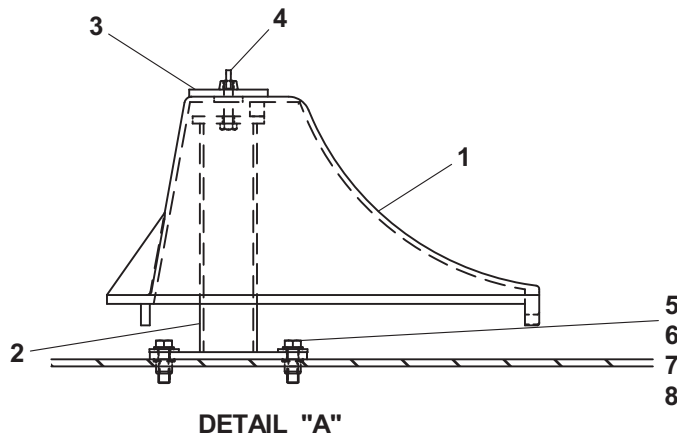
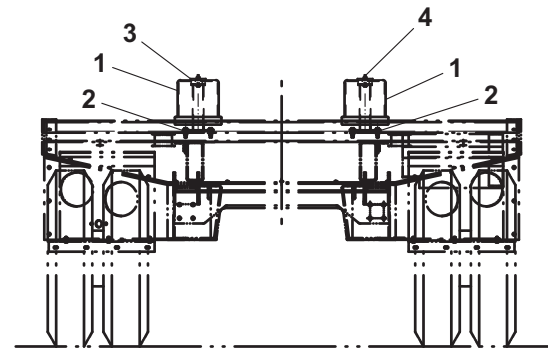
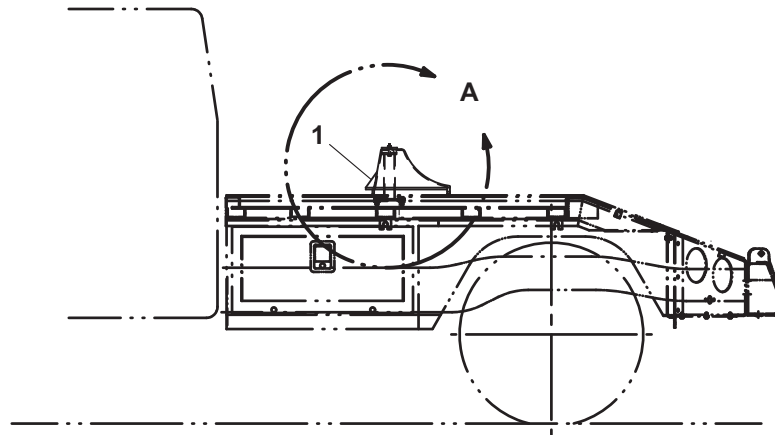

STONE GUARD - TUNNEL TOOLBOX

ITEM	PART NO.	DESCRIPTION	QTY
1	4706005883	Plate LH (Stainless Steel)	1
	4707000348	Plate LH (Aluminum Diamond)	
2	4706005884	Plate RH (Stainless Steel)	1
	4707000349	Plate RH (Aluminum Diamond)	
3	7114100618	Capscrew, #10-24NC x 0.75"	18
4	7950100103	Flatwasher, #10 ID	36
5	7660102604	Locknut, #10-24NC	18

STONE GUARD - TUNNEL TOOLBOX

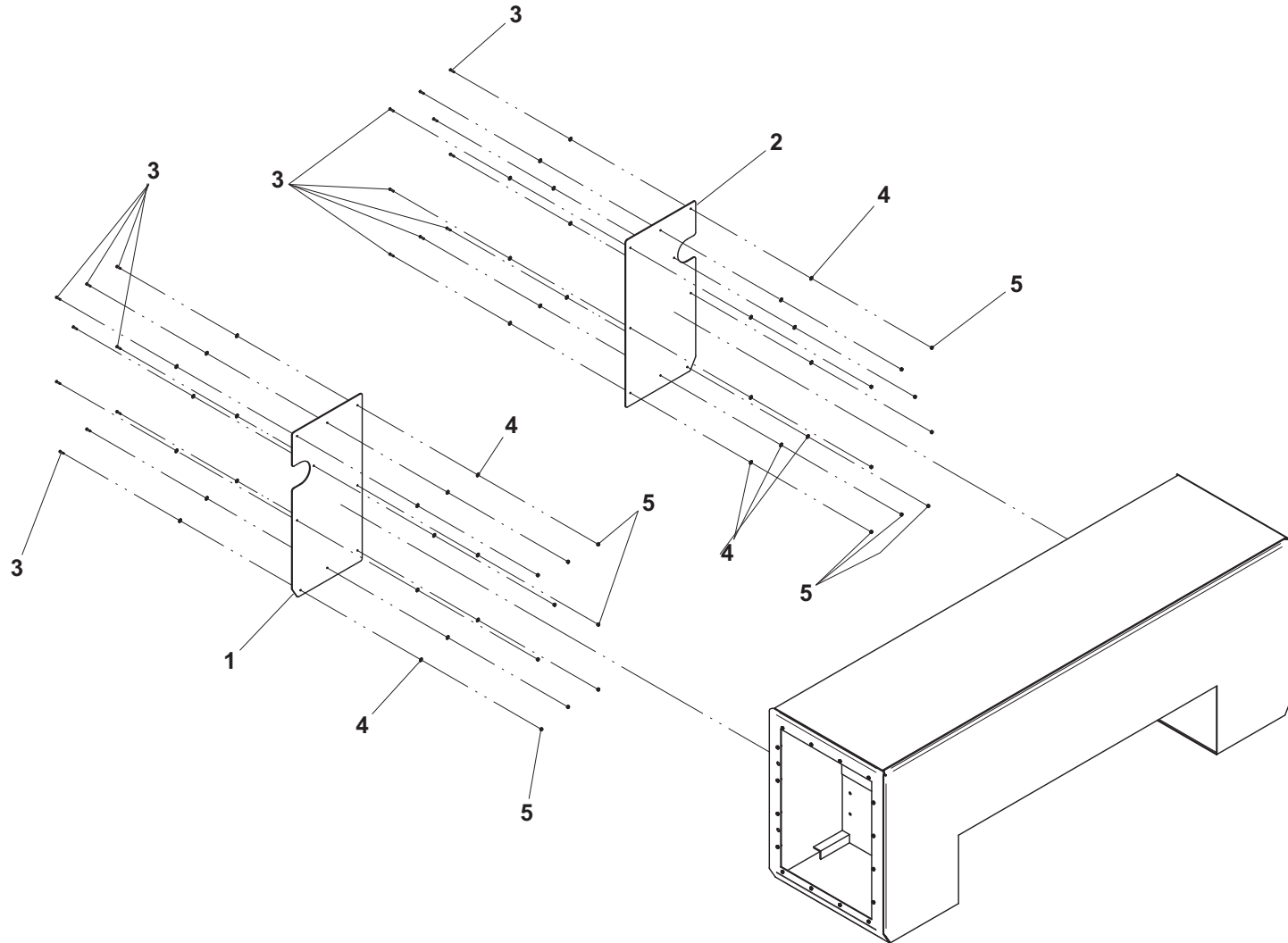

BATTERY BOX - TUNNEL TOOLBOX

ITEM	PART NO.	DESCRIPTION	QTY
1	4763000418	Threaded Rod	1
2	4062000687	Bar	1
3	7950140153	Flatwasher, .025" ID	6
4	7660142604	Locknut, 0.25"-20NC	2
5	3314000050	Coverplate	1
6	7120000070	Thumbscrew, 0.25"-20NC x 1.00"	4
7	7413000002	Nutsert, 0.25"-20NC	4
8	7493000014	Grommet - 2.00" OD	2
9	4811001192	Sheet	1
10	7759000020	Rivet	2

BATTERY BOX - TUNNEL TOOLBOX

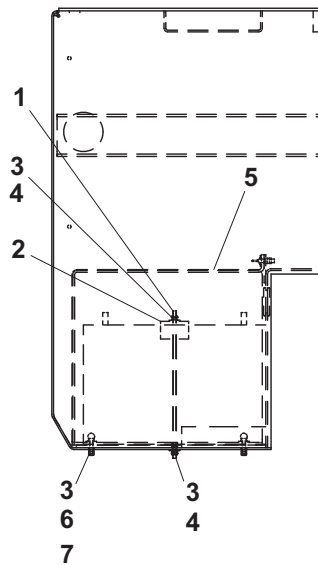
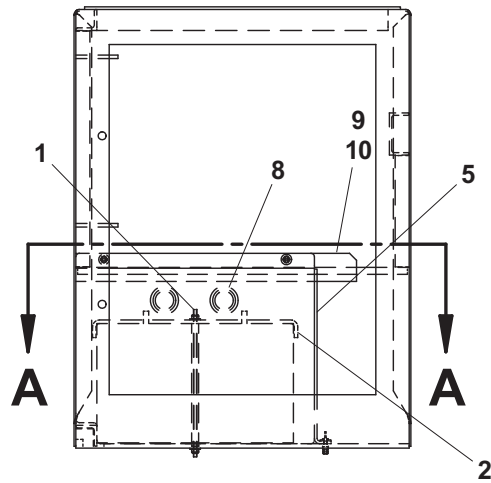
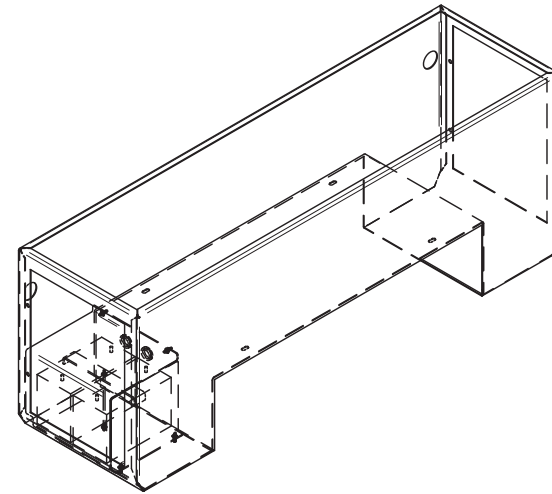
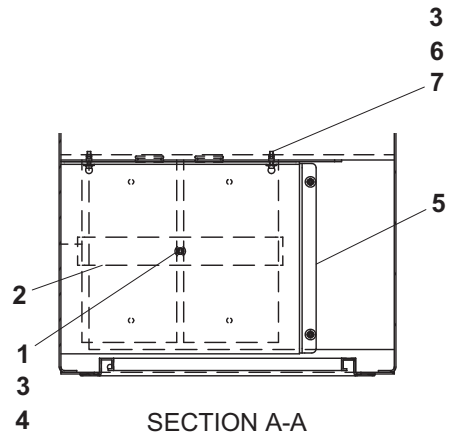

Items #9 and #10 are only used in the Steel Tunnel Toobox

PULL-OUT DRAWER - TUNNEL TOOLBOX

ITEM	PART NO.	DESCRIPTION	QTY
1	4811001178	Sheet	1
2	4811001179	Sheet	1
3	7821000006	Slide	1pr
4	7114100618	Capscrew, #10-24NC x 0.75"	34
5	7950100103	Flatwasher, #10 ID	68
6	7660102601	Locknut, #10-24NC	34
7	4706005865	Plate	2
8	4706005864	Plate	2
9	7114100618	Capscrew, 0.25"-20NC x 1.25"	4
10	7950140141	Flatwasher, 0.25" ID	8
11	7660142601	Locknut, 0.25"-24NC	4
12	4763000184	Rod	2
13	7115161250	Capscrew, 0.38"-16NC x 1.50"	4
14	7950160153	Flatwasher, 0.38" ID	8
15	7949000015	Washer	2
16	7660162601	Locknut, 0.38"-16NC	4
17	4679000253	Pad	1

PULL-OUT DRAWER - TUNNEL TOOLBOX

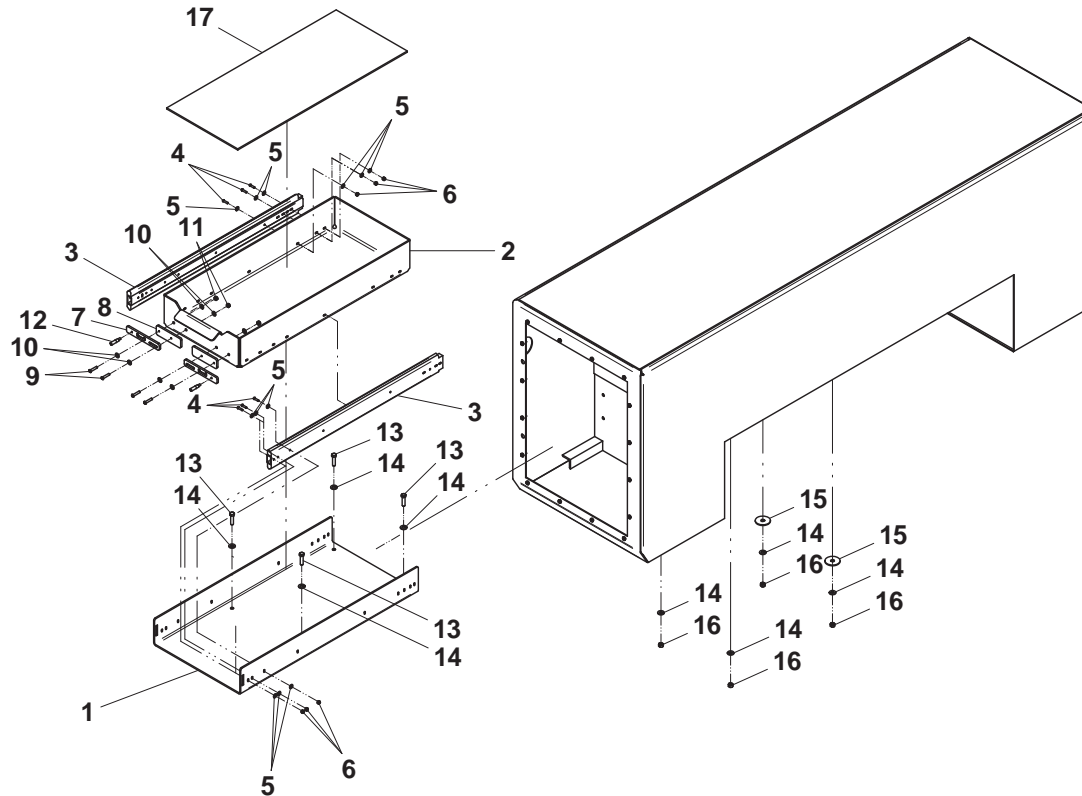

FORD DIESEL 08 EXHAUST ALTERATION

ITEM	PART NO.	DESCRIPTION	QTY
1	7696000068	Exhaust Pipe	1
2	7274000111	Muffler Clamp	2
3	7696000070	Exhaust Pipe	1
4	4178000743	Bracket	2
5	7115150850	Capscrew, 0.31"-18NC x 1.00"	4
6	7950150161	Flatwasher, 0.31" ID	8
7	7660152601	Locknut, 0.31"-18NC	4
8	4377000002	Cut-Off Template	1

FORD DIESEL 08 EXHAUST ALTERATION

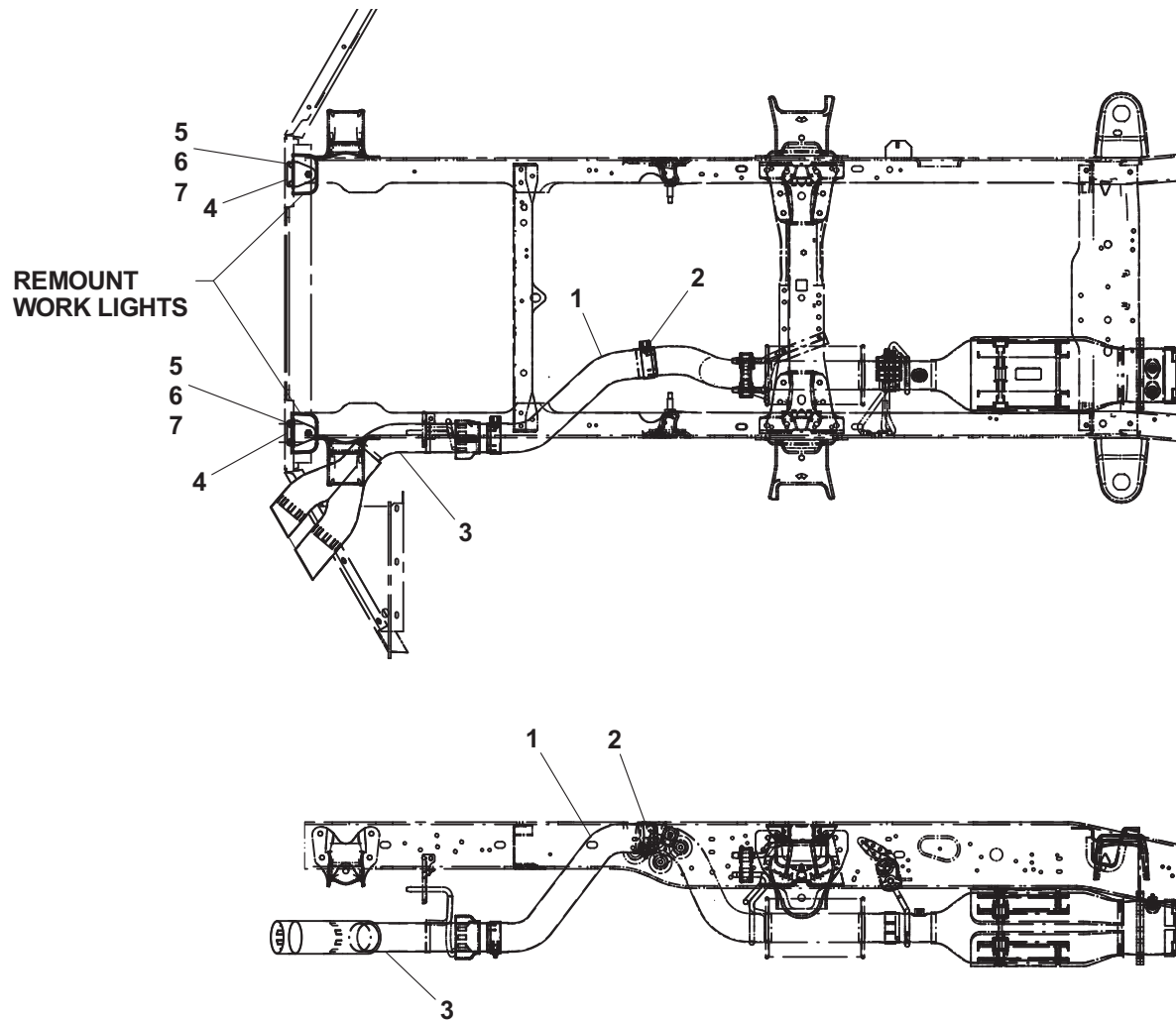

Item #8, Cut-Off Template, not shown

DODGE DIESEL 08 EXHAUST ALTERATION

ITEM	PART NO.	DESCRIPTION	QTY
1	7696000056	Exhaust Pipe	1
2	4178000718	Bracket	1
3	7274000110	Muffler Clamp	2
4	7115181850	Capscrew, 0.50"-13NC x 2.25"	1
5	7950180161	Flatwasher, 0.50" ID	2
6	7660182601	Locknut, 0.50"-13NC	1

DODGE DIESEL 08 EXHAUST ALTERATION

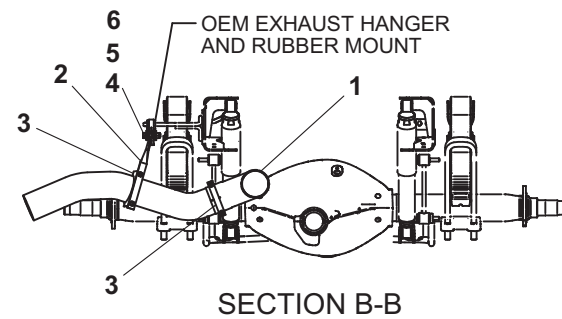
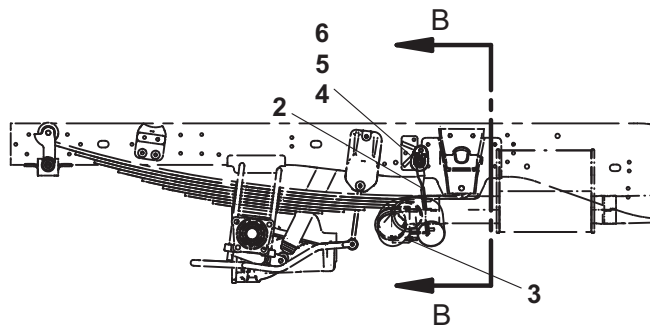
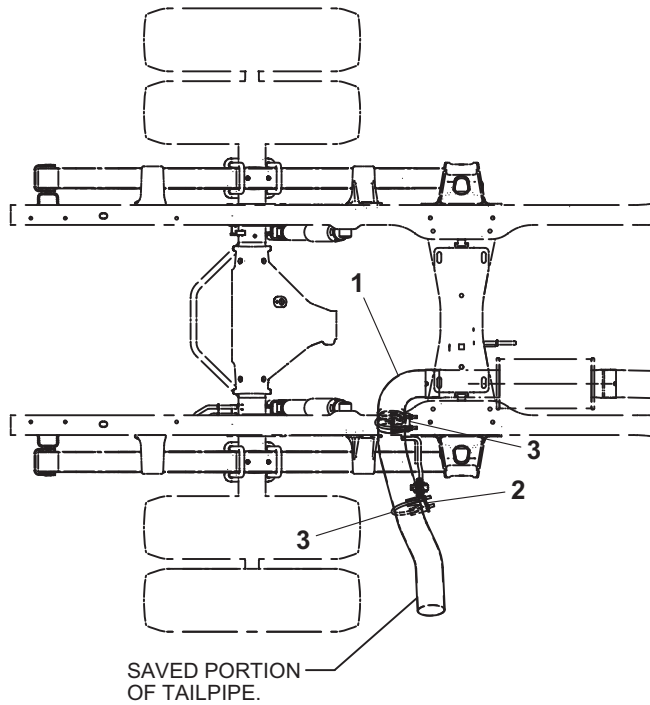

FOREIGN CHASSIS LIGHTS AND WIRING

ITEM	PART NO.	DESCRIPTION	QTY
1	7552000461	Harness	1
2	7590000116	Lamp Kit	2
3	7493000002	Grommet	2
4	4178000893	Bracket, LH	1
5	4178000894	Bracket, RH	1
6	7111151010	Screw, 0.31"-18NC x 1.25"	2
7	7950150161	Flatwasher, 0.31" ID	2
8	7950150000	Lockwasher, 0.31" ID	2
6	7660150000	Hexnut, 0.31"-18NC	1
7	7894000042	Tie Strap	8

FOREIGN CHASSIS LIGHTS AND WIRING

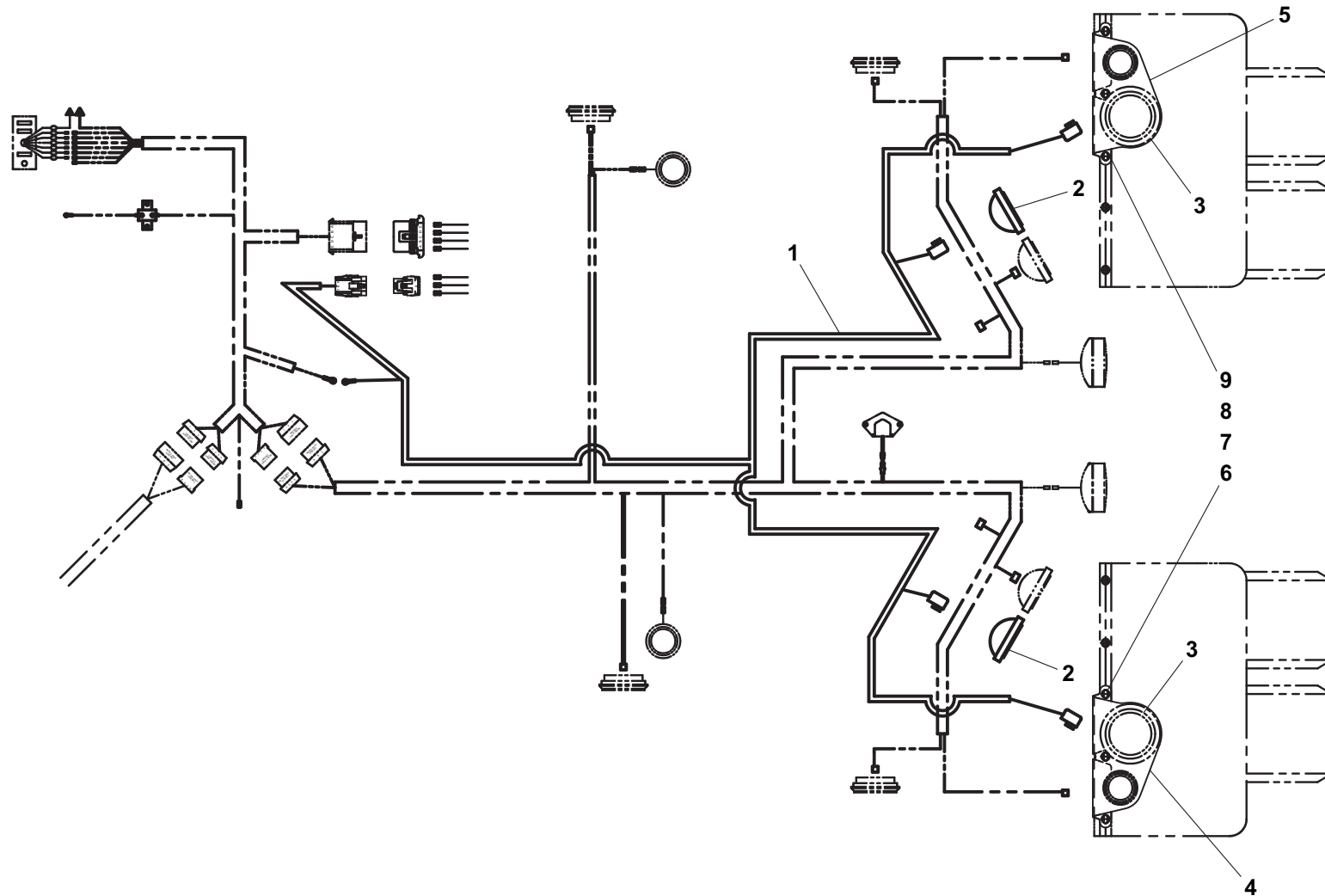

Item #10, Tie Strap, not shown

FUEL FILLER

ITEM	PART NO.	DESCRIPTION	QTY
1	7449000019	Fuel Bezel	1
2	7796000100	Gasket	1
3	7950100151	Flatwasher, 0.19" ID	4
4	4533000415	Fuel Hose (Ford)	1
	7570000027	Fuel Hose (GMC, diesel)	
	7570000028	Fuel Hose (GMC, gas)	
	7570000037	Fuel Hose (Dodge)	
5	4533000415	Bracket	1
6	7115161050	Capscrew, 0.38"-16NC x 1.25"	1
7	7950160141	Flatwasher, 0.38" ID	1
8	7660162601	Locknut, 0.38"-16NC	1
9	5526000553	Tie Strap	8
10	7570000021	Vent Hose (GMC)	6 ft
	7570000036	Vent Hose (Dodge)	
11	7443000354	Fitting (GMC, gas)	2
12	7114100810	Screw, #10-24NC x 1.00"	4
13	7660102604	Locknut #10-24NC	4

FUEL FILLER

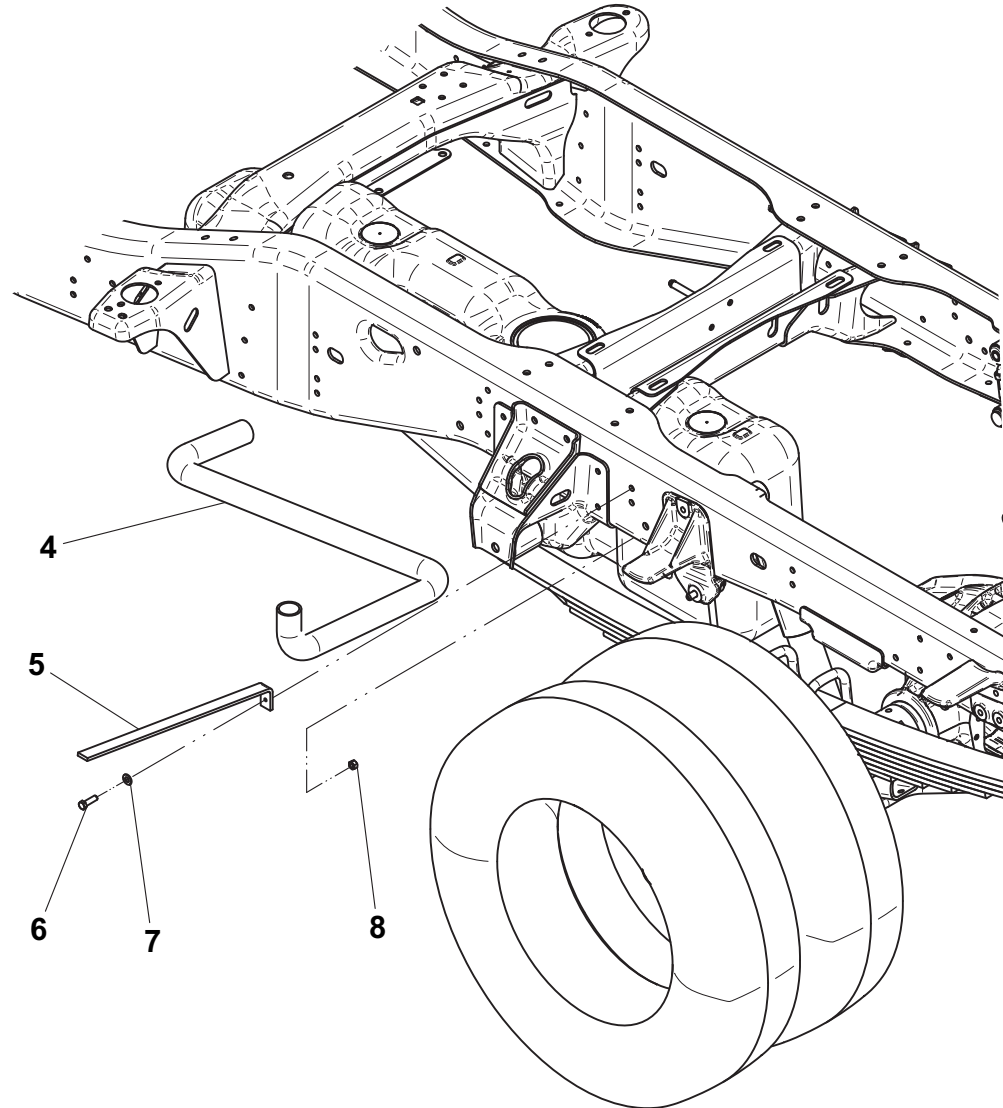

Not all items shown because of chassis variation

THIS PAGE INTENTIONALLY LEFT BLANK