

JD16INT COMPOSITE BODY MEDIUM DUTY WRECKER PARTS MANUAL

JERR-DAN[®]

An Oshkosh Corporation Company

13224 Fountainhead Plaza
Hagerstown, MD 21742
Phone (717) 597-7111
www.jerr-dan.com

5-376-000161
Rev 0 - November 01, 2012

© 2012 Jerr-Dan Corporation. All Rights Reserved.

This manual covers the following Jerr-Dan Models:

JD16INT - 16 Ton Integrated With Composite Body

Jerr-Dan Corporation strives to provide information that is accurate, complete and useful. Descriptions and illustrative material contained within this manual are as accurate as known at the time of publication and are subject to change, without notice, as a result of continuous product improvements. Jerr-Dan reserves the right to amend the information in this document at any time without prior notice.

Information contained in this manual reflects how this vehicle was built at the factory. Modifications or additions by the distributor or owner are not reflected in this manual.

This parts manual does not include service parts information for the commercial chassis (IHC, Ford, GM, etc.). That information is provided by the chassis manufacturer.

When ordering parts, please refer to your unit's Serial Number and Model Number. This information is be found on the aluminum tag riveted to the inside of the driver's side rear compartment of the main body.

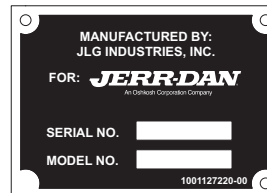

Additional or replacement manuals can be ordered by calling Jerr-Dan Parts at 717-597-7111. Price and availability will be quoted at time of the request.

Please report comments and/or errors by contacting Jerr-Dan Corporation's Technical Publications Department by e-mail at technicalpublications@jerr-dan.com or by FAX on 717-485-7162.

Manufactured under one or more of the following patents: 5,575,606; 5,672,042; 5,697,741; 5,713,714; 5,722,810; 5,782,596; 5,839,775 and 6,315,515 B1 with other Patents Pending.

Jerr-Dan and the Jerr-Dan logo are registered trademarks and Run Hard is a service mark of Jerr-Dan Corporation, Greencastle, PA USA.

The material in this document is confidential and the property of Jerr-Dan Corporation. No part of this document may be photocopied, Reproduced or translated to another language without the express written consent of Jerr-Dan Corporation.

THIS PAGE INTENTIONALLY LEFT BLANK

INDEX

DESCRIPTION	PAGE	DESCRIPTION	PAGE
Subframe Installation - 112" CA / 86" CT Body.....	6	Tool Holder Installation 49" & 60" Toolbox.....	96
Subframe Hydraulic Tubing.....	8	Mudflap Installation.....	98
Hydraulic Tank Installation.....	10	Back-up Alarm Installation - 97DB Fixed & 82-102DB Variable.....	100
Valve Bank Cover Installation.....	12	Battery Box Installation.....	102
Rear Deck Assembly.....	14	Wheel Dolly and Bracket Installation.....	104
Rear Spade Installation.....	16	Light Pylon Installation - 49/60" Toolbox.....	106
Spade Cylinder Assembly - 3320000083.....	18	Light Pylon Installation - 30" Toolbox.....	108
Boom Installation.....	20	Light Pylon Assembly - 38", 43" & 51".....	110
Boom Lift Cylinder Assembly - 3320000085.....	22	Body Light and Wiring Installation.....	112
Wrecker Boom Assembly - 2 Piece.....	24	Headboard Light and Wiring Installation.....	116
Wrecker Boom Extension Cylinder Assembly - 3320000080.....	26	Lightbar Installation.....	118
Boom Tube Assembly.....	28	Lightbar - Code 3 - 1001136990.....	120
Winch Installation - 15K Superwinch Planetary.....	30	Lightbar - Whelen - 1001129872.....	122
Winch 15K Superwinch - 7970000080.....	32	Supply Pressure and Return Assembly.....	126
Winch Installation - 15K DP Planetary.....	34	Hydraulic Lines and Fittings.....	128
Winch - 15K DP - 7970000084 - Motor End Installation.....	36	Controls and Valve Assembly.....	136
Winch - 15K DP - 7970000084 - Drum Installation.....	38	Valve Assembly - 7935000293.....	144
Winch - 15K DP - 7970000084 - Gear End Installation.....	40	Switch Panel Installation 6 Function - 3870000005.....	146
Winch - 15K DP - 7970000084 - Input Shaft Installation.....	42	Switch Panel Installation 6 Function, 3 Underlift - 3870000022.....	148
Winch - 15K DP - 7970000084 - Input Shaft Installation.....	43	Switch Panel Installation 9 Function - 3870000007.....	150
Winch - 15K DP - 7970000084 - Base Mount Installation.....	44	Switch Panel Installation 9 Function, 3 Underlift - 3870000021.....	152
Winch - 15K DP - 7970000084 - Gear End Cover Installation.....	46	Switch Panel Installation 9 Function In-Dash - 3870000009.....	154
Winch Air Shift.....	48	Trailer Towing Package.....	156
Underlift Installation.....	50	Decals.....	158
Underlift Tilt Cylinder Assembly - 3320000139.....	52		
Underlift Assembly - 3170000294.....	54		
Underlift Extension Cylinder Assembly - 3320000072.....	56		
Crosstube Installation.....	58		
Underlift Tools - Frame Forks.....	60		
Underlift Tools - L-Arm Assembly - 2504880010.....	62		
Underlift Tools - Fifth Wheel Attachment - 2503880077.....	66		
Underlift Tools - Ball Hitch.....	68		
Underlift Tools - Pintle Hook.....	70		
Rear Tail Plate Installation.....	72		
Truck Bar Installation.....	74		
Truck Bar - 7002000355.....	76		
Body Configurations.....	78		
Body Mount Assembly.....	80		
60" & 49" Toolbox Assembly.....	82		
60" & 49" Toolbox Door Assembly.....	84		
60" & 49" Toolbox Body Panel Installation.....	86		
30" Toolbox Body Door Assembly.....	88		
30" Toolbox Body Panel Installation.....	90		
Body Panel Assembly - 108" CA Base.....	92		
30", 49" & 60" Toolbox Spacer and Bracket Assembly.....	94		

SUBFRAME INSTALLATION - 112" CA / 86" CT BODY

ITEM	PART NO.	DESCRIPTION	QTY
1	3868000282	Subframe	1
2	4706002918	Plate	2
3	4706002919	Plate	2
4	4706002921*	Plate	2
5	4706002922*	Plate	2
6	4706002925*	Plate	2
7	4706002926*	Plate	2
8	4706002927*	Plate	2
9	4706002928*	Plate	2
10	4706002929*	Plate	2
11	4706002930*	Plate	2
12	4706002931*	Plate	2
13	4706002932*	Plate	2
14	7118201616	Capscrew, 0.63"-11NC x 2.00"	22
15	7661000018	Nut, 0.63"-11NC	22
16	7262000038	Chain	2
17	7274000109	Clamp	2

* Also Available In Shim Kit - 3577000053

SUBFRAME INSTALLATION - 112" CA / 86" CT BODY

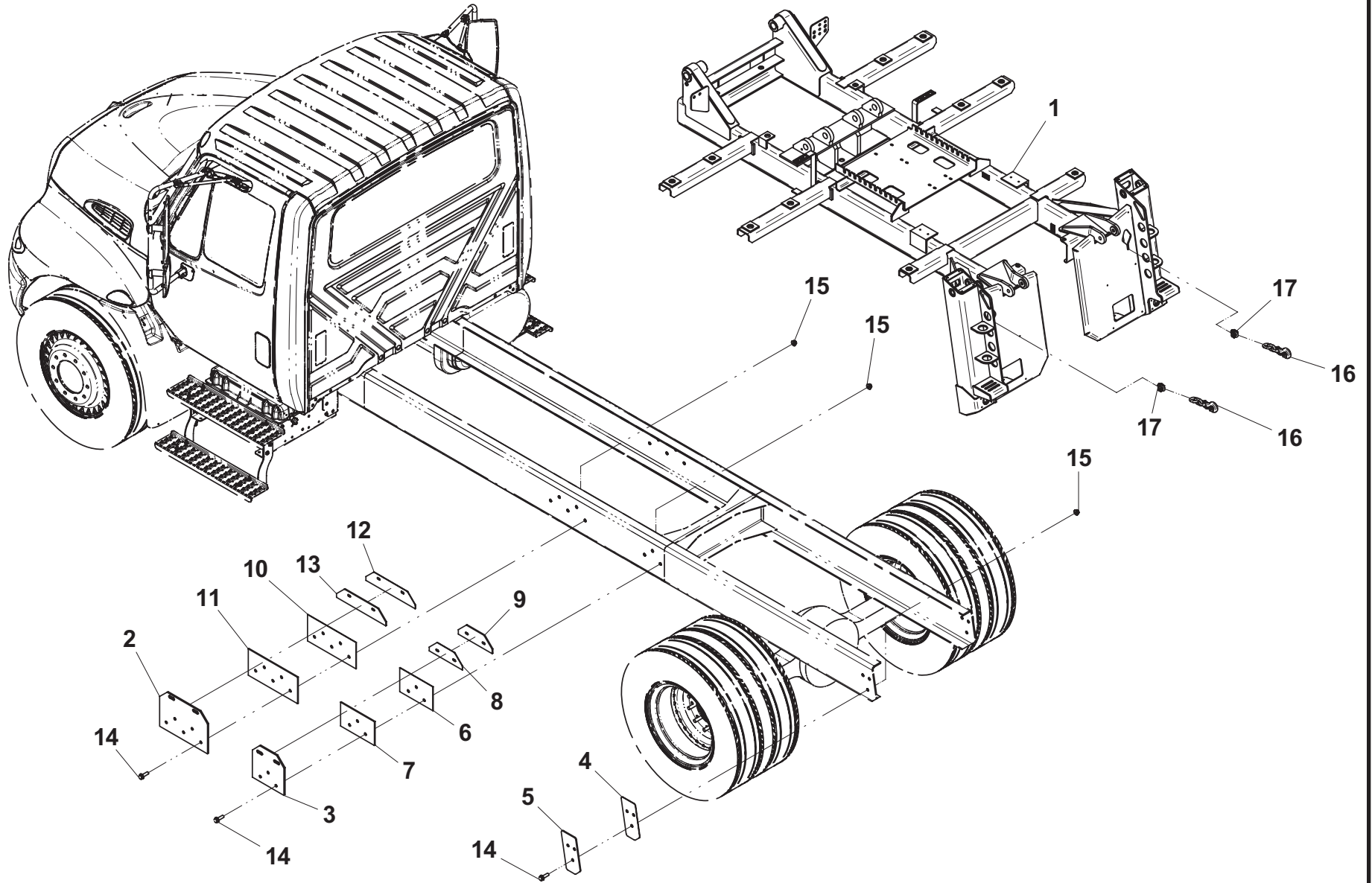

SUBFRAME HYDRAULIC TUBING

ITEM	PART NO.	DESCRIPTION	QTY
1	7912000295*	Tube Assembly	2
2	7912000294*	Tube Assembly	2
3	7912000293*	Tube Assembly	2
4	7912000336*	Tube Assembly	1
5	7912000337*	Tube Assembly	1
6	7912000338*	Tube Assembly	1
7	7912000339*	Tube Assembly	1
8	7445080825	Union, Bulkhead	4
9	7445060625	Fitting	6
10	1001140895	Clamp Kit Stackable, 3/8" OD	2
11	1001140894	Clamp Kit Stackable, 1/2" OD	3
12	7443000241	Fitting	4
13	7443000108	Restrictor	1
14	7443000231	Fitting	4
15	1001140722	Clamp Kit, 3/8" OD	4
16	1001136559	Clamp Kit, 1/2" OD	1

* Available in Hydraulic Tubing Kit - 7577000680

SUBFRAME HYDRAULIC TUBING

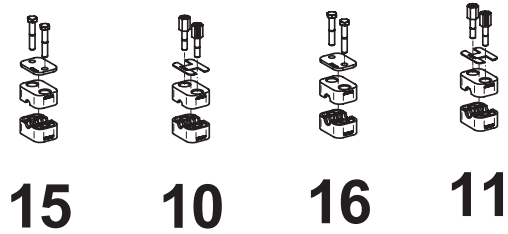
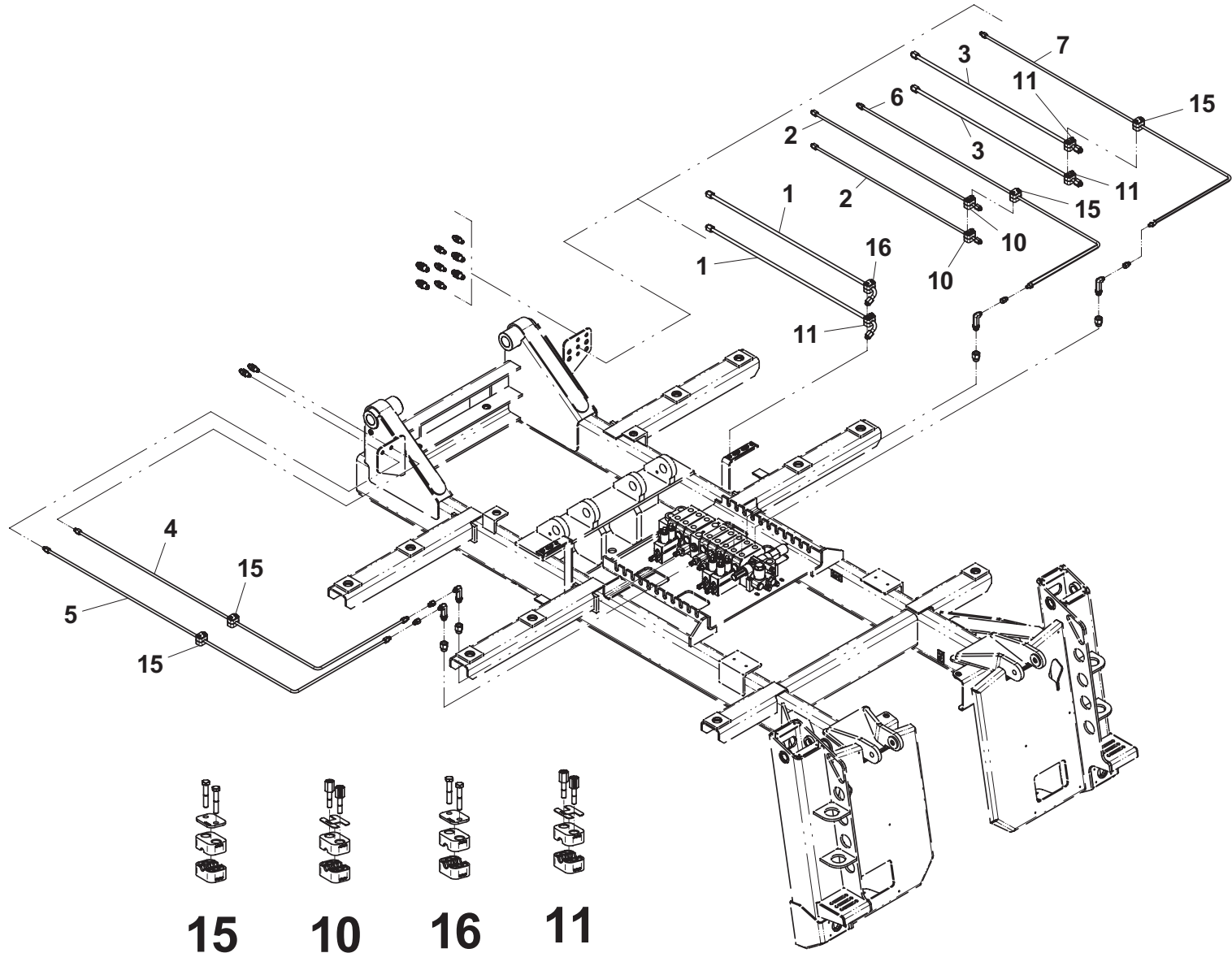

HYDRAULIC TANK INSTALLATION

ITEM	PART NO.	DESCRIPTION	QTY
1	3750000027	Hydraulic Tank Assembly	1
2	7115181850	Capscrew, 0.50"-13NC x 2.25"	4
3	7950180141	Flatwasher, 0.50" ID	4
4	7660182601	Locknut, 0.50"-13NC	4
5	7949000015	Washer, Head	4
6	7949000016	Washer, Tail	4
7	7636000006	Rubber Mount	4
8	7470000003	Sight Gauge	1
9	7183000002	Filler/Breather Cap Assembly	1

HYDRAULIC TANK INSTALLATION

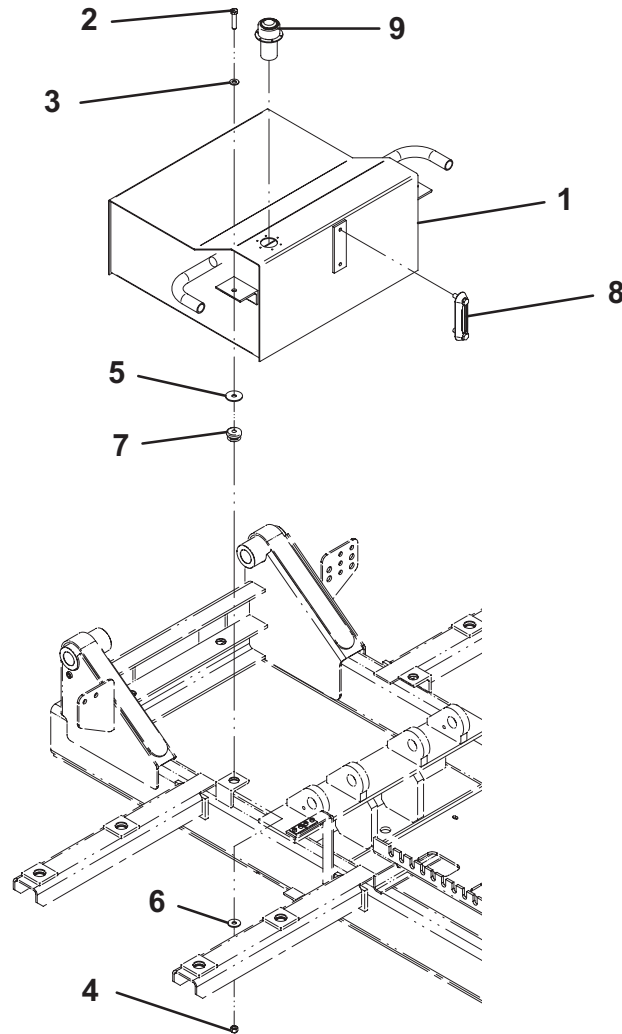

VALVE BANK COVER INSTALLATION

ITEM	PART NO.	DESCRIPTION	QTY
1	4811001079	Valve Bank Cover	1
2	7114140518	Capscrew, 0.25"-20NC x 0.62"	4
3	7413000002	Nutsert, 0.25"-20NC	4
4	7790141056	Capscrew, 0.25"-20NC x 0.63"	4
5	7950140153	Flatwasher, 0.25" ID	4
6	8632000002	Rubber Trim 0.63" x 0.13"	3.5ft

VALVE BANK COVER INSTALLATION

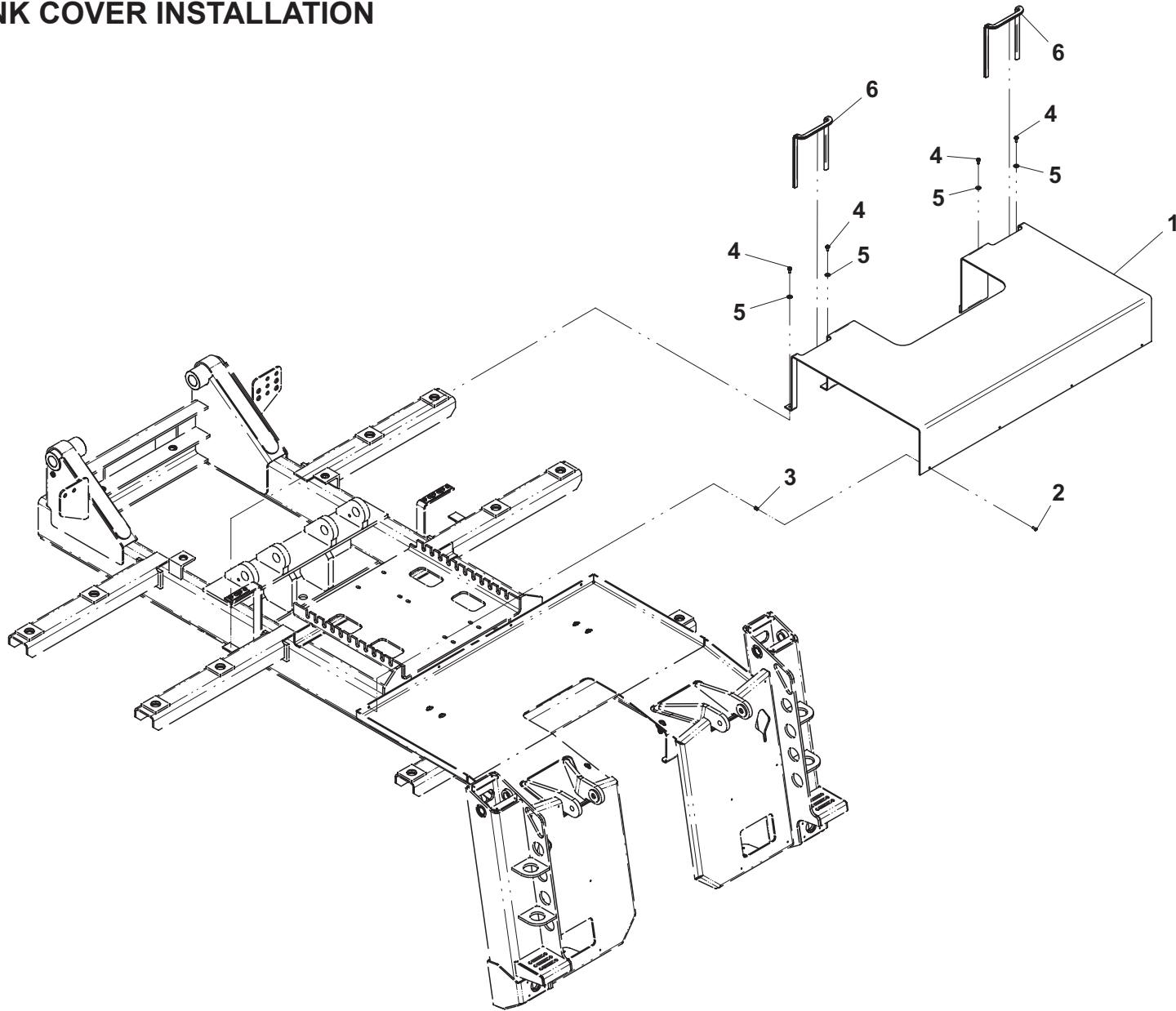

REAR DECK ASSEMBLY

ITEM	PART NO.	DESCRIPTION	QTY
1	4707000223	Plate	1
2	7636000014	Rubber Mount	2
3	7114161618	Capscrew, 0.38"-16NC	2
4	7660162601	Locknut, 0.38"-16NC	2
5	7950160153	Flatwasher, 0.38" ID	2
6	7114161018	Capscrew, 0.38"-16NC	4

REAR DECK ASSEMBLY

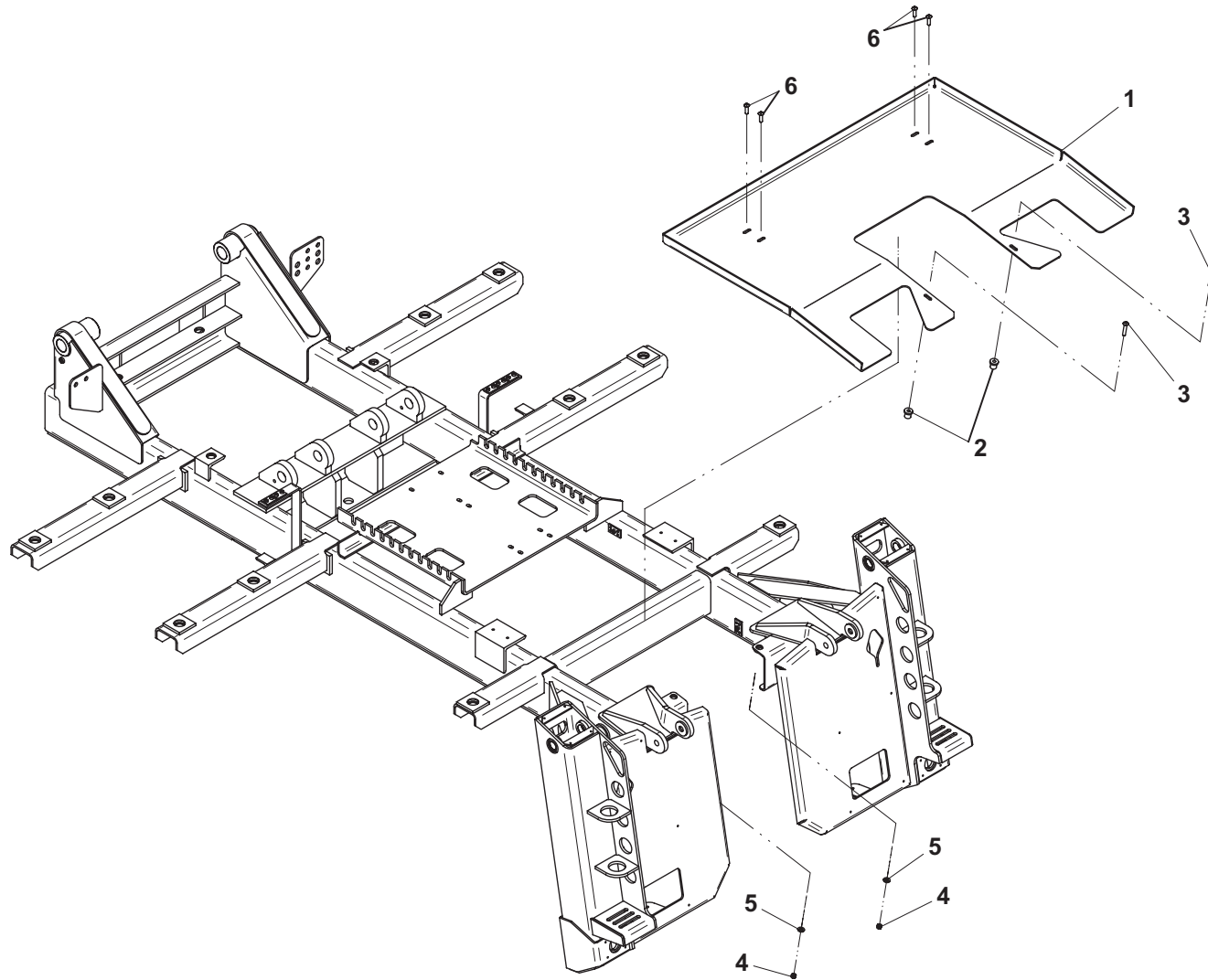

REAR SPADE INSTALLATION

ITEM	PART NO.	DESCRIPTION	QTY
1	3913000071	Channel Spade LH	1
2	3913000072	Channel Spade RH	1
3	3706000142	Spade Claw (Standard)	2
4	4706002992	Plate	2
5	7691000031	Pin	2
6	4706002887	Plate	6
7	7114140518	Capscrew, 0.25"-20NC x 0.62"	16
8	7950140000	Lockwasher, 0.25" ID	16
9	7950140141	Flatwasher, 0.25" ID	8
10	3320000083	Spade Cylinder Assembly	2
11	4691000345	Pin	2
12	4691000346	Pin	2
13	7754000062	Retaining Ring	8
14	3178000563*	Spade Foot Pivot (Optional)	2
15	3178000564*	Spade Foot	2
16	4691000608*	Pin	2
17	7754000006*	Retaining Ring	4
18	3691000281*	Pin	2
19	7691000019*	Pin	2

* Item available in Option, P/N 2849000050

REAR SPADE INSTALLATION

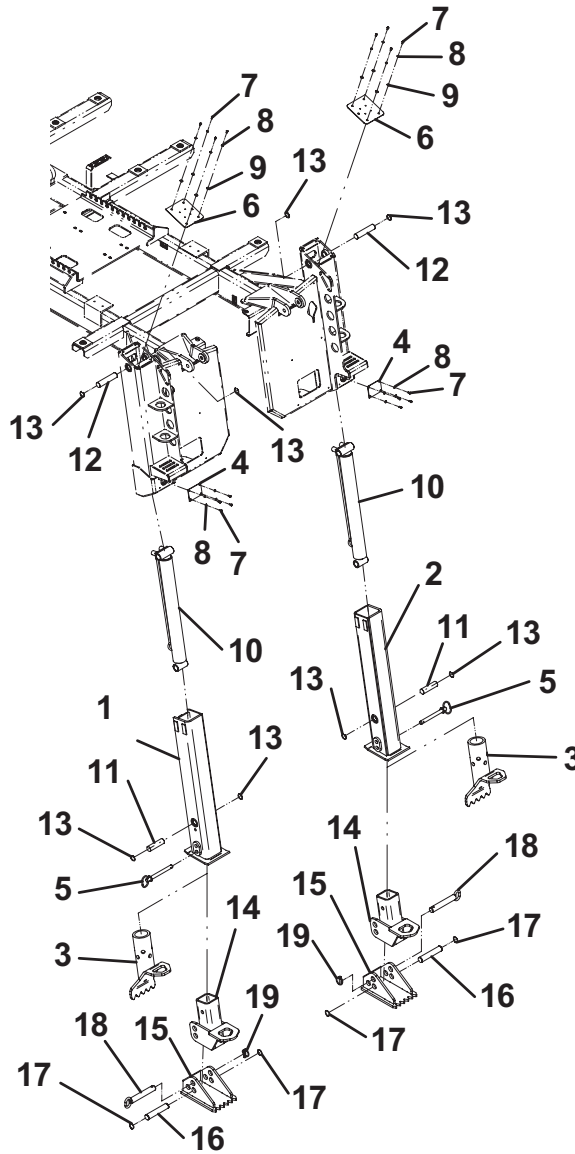

SPADE CYLINDER ASSEMBLY - 3320000083

ITEM	PART NO.	DESCRIPTION	QTY
1	3071000077	Barrel Weldment	1
2	3763000096	Rod Weldment	1
3	7661000034	Locknut, 1.00"-14NF	1
4	7796000053*	Ring, Wear	2
5	7796000067*	Seal, Piston	1
6	4698000015*	Piston	1
7	7755222609*	Ring, Back-up	2
8	7755222000*	Seal, "O" Ring	1
9	7754000071	Retaining Ring	2
10	7755330000^	Seal, "O" Ring	1
11	7755330609^	Ring, Back-up	1
12	7754000054^	Ring, Wear	1
13	4553000016^	Head	1
14	7796000045^	Seal, Rod	1
15	7796000046^	Seal, Rod Wiper	1
16	7440030000	Grease Fitting	1
17	7253000002	Cap, Grease Fitting	1

* Included in Piston Assembly, P/N 3698000006

^ Included in Head Assembly, P/N 3553000016

Service Seal Kit, P/N 7577250206

SPADE CYLINDER ASSEMBLY - 3320000083

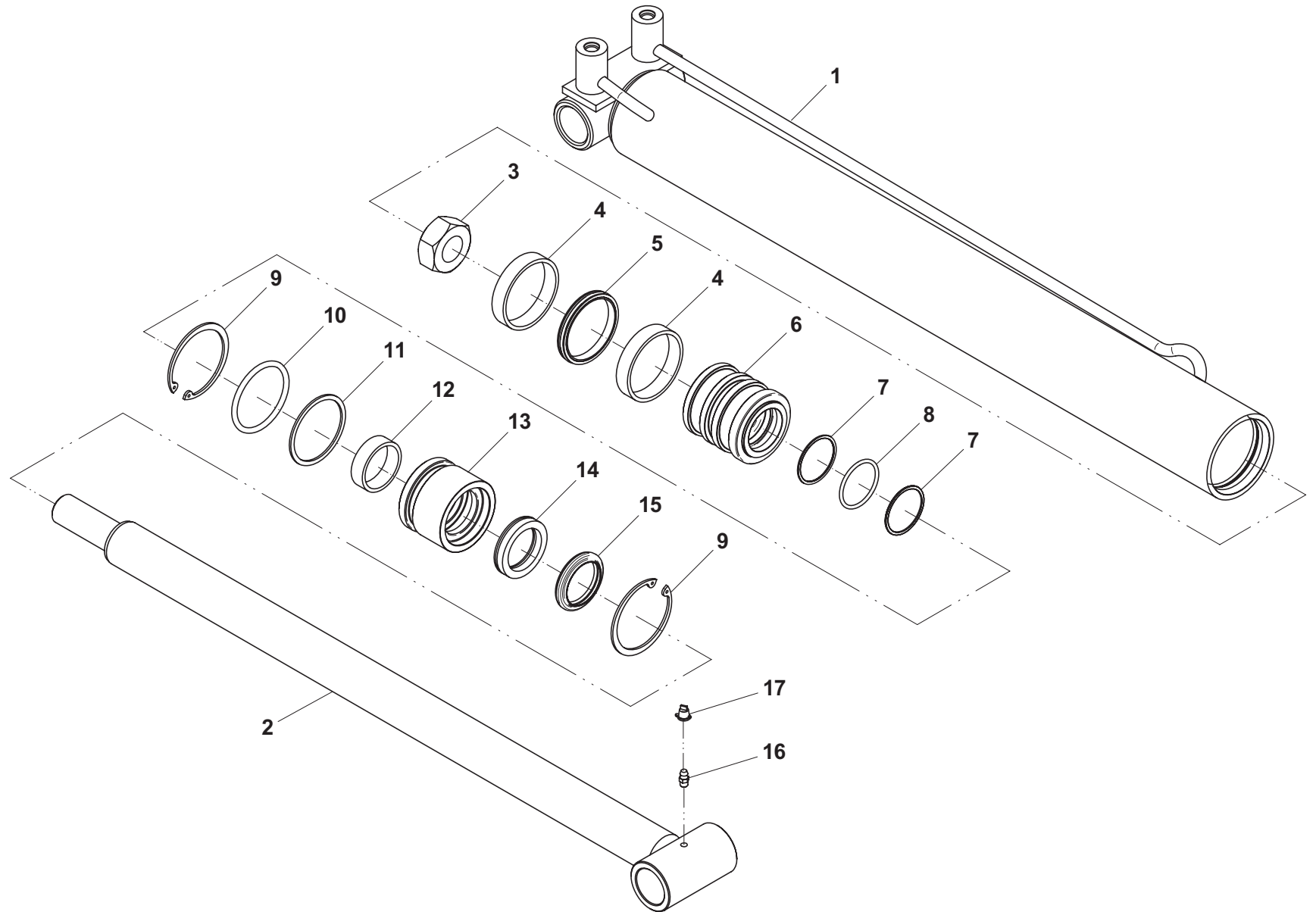

BOOM INSTALLATION

ITEM	PART NO.	DESCRIPTION	QTY
1	3170000319	Boom Assembly	1
2	3320000085	Lift Cylinder Assembly	2
3	3691000174	Pin	2
4	3691000176	Pin	2
5	3691000175	Pin	1
6	7115160850	Capscrew, 0.38"-16NC x 1.00"	1
7	7950160161	Flatwasher, 0.38" ID	1
8	7950160000	Lockwasher, 0.38" ID	1
9	7209000039	Bushing	2
10	4949000053	Washer, 3.00" OD x 1.81" ID x 0.06"	2
11	4949000054	Washer, 3.00" OD x 1.81" ID x 0.09"	2
12	7440030000	Grease Fitting	5
13	7804000003	Shackle	1
14	7115161650	Capscrew, 0.38"-16NC x 2.00"	4
15	7660161600	Locknut, 0.38"-16NC	4
16	7950160160	Flatwasher, 0.38" ID	8
17	7253000002	Grease Fitting Cap	5

BOOM INSTALLATION

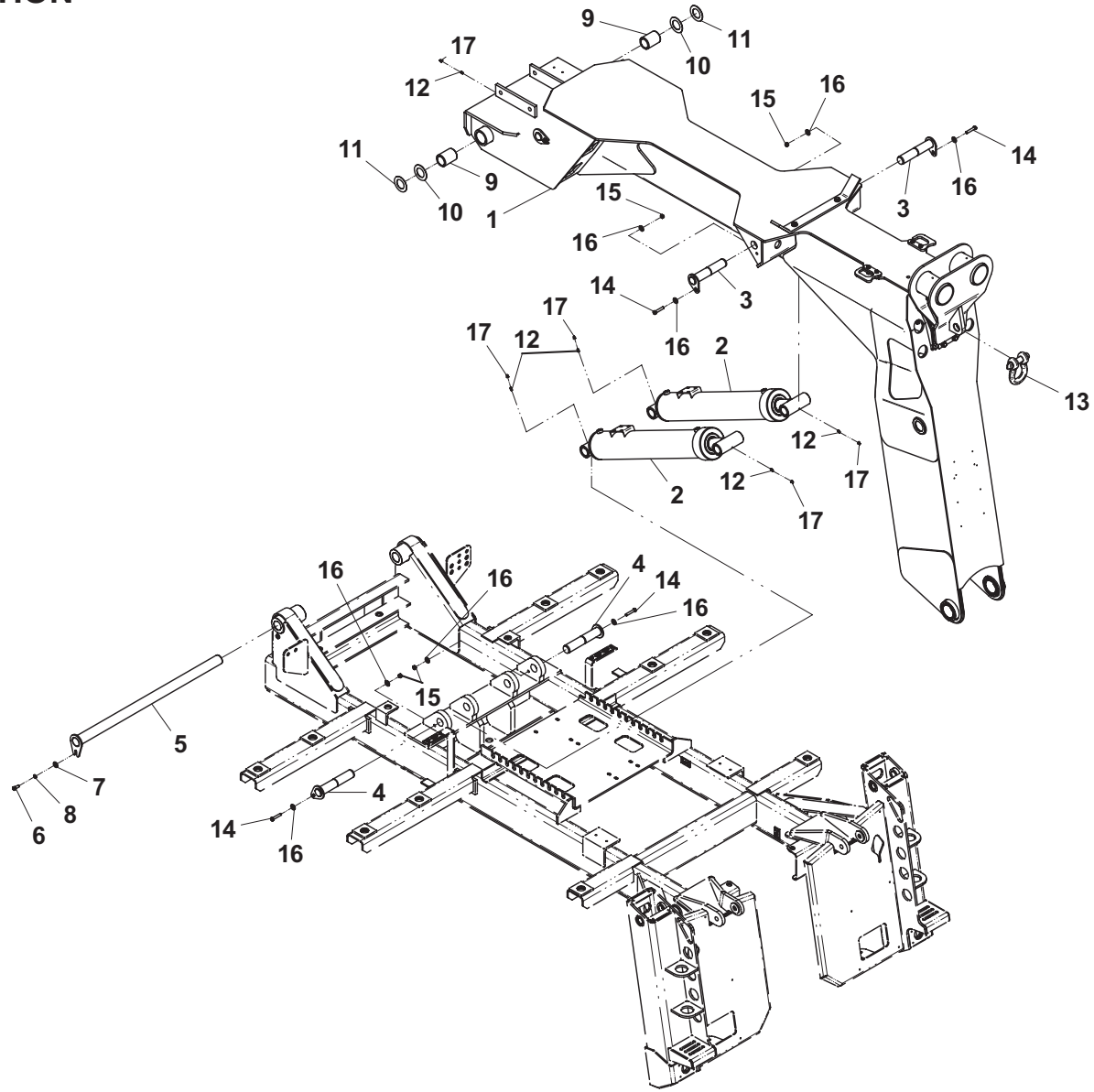

BOOM LIFT CYLINDER ASSEMBLY - 3320000085

ITEM	PART NO.	DESCRIPTION	QTY
1	3071000079	Barrel Weldment	1
2	3763000095	Rod Weldment	1
3	7661000035	Locknut, 1.50"-12NF	1
4	7754000065*	Ring, Wear	2
5	7796000061*	Seal, Piston	1
6	4698000017*	Piston	1
7	7755226609*	Ring, Back-up	2
8	7755226000*	Seal, "O" Ring	1
9	7755346000^	Seal, "O" Ring	1
10	7755346609^	Ring, Back-up	1
11	7754000066^	Ring, Wear	1
12	4553000018^	Head	1
13	7796000025^	Seal, Rod	1
14	7796000011^	Seal, Rod Wiper	1
15	4254000014	Cap	1

* Included in Piston Assembly, P/N 3698000008

^ Included in Head Assembly, P/N 3553000018

Service Seal Kit, P/N 7577250236

BOOM LIFT CYLINDER ASSEMBLY - 3320000085

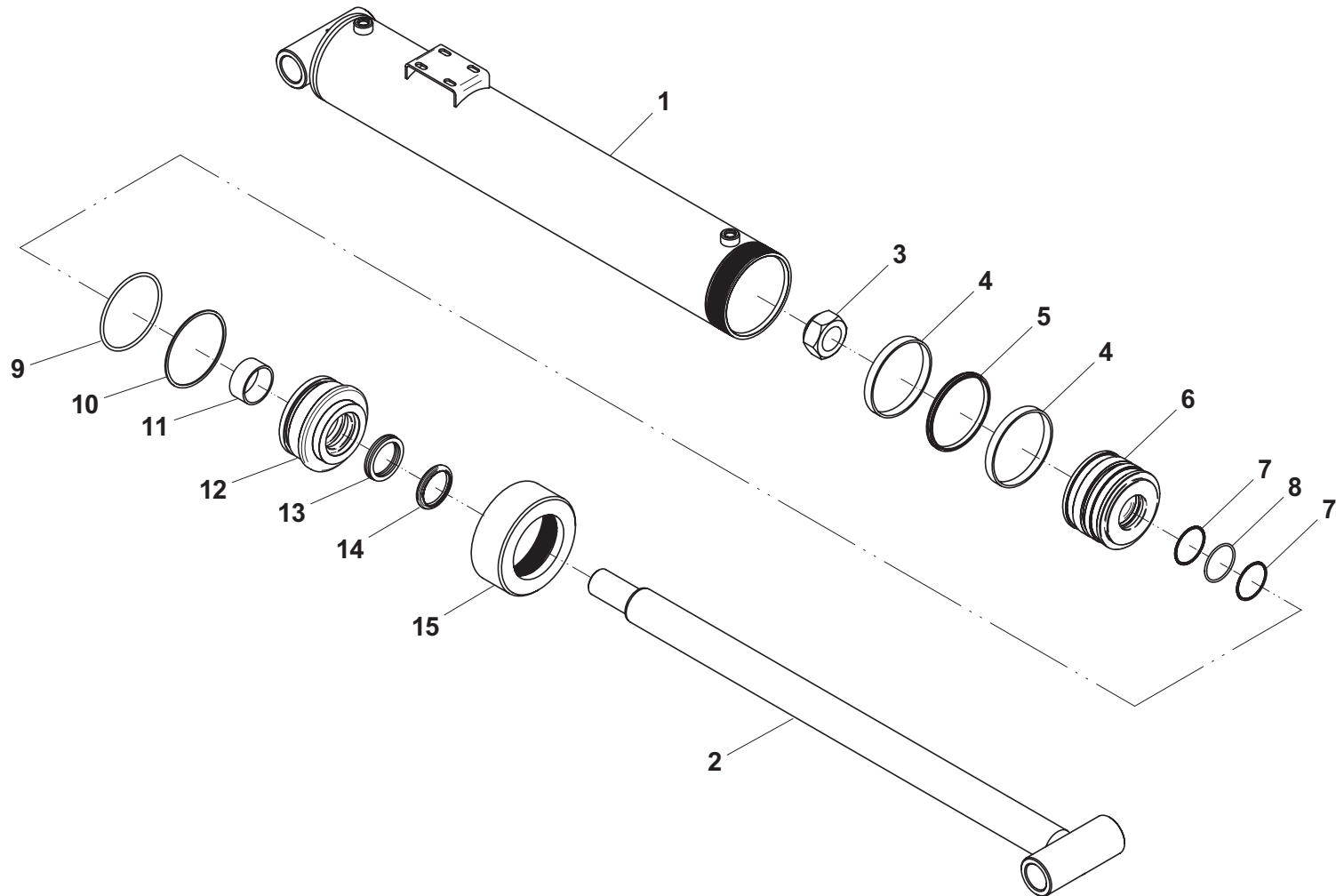

WRECKER BOOM ASSEMBLY - 2 PIECE

ITEM	PART NO.	DESCRIPTION	QTY
1	3170000192	Boom Weldment, Fly Section	1
2	3170000318	Boom Weldment, Base Section	1
3	3320000080	Extension Cylinder Assembly	1
4	4691000333	Pin	1
5	7754000043	Retaining Ring	2
6	3691000173	Pin	1
7	7950160251	Flatwasher, 0.38" ID	2
8	7115161250	Capscrew, 0.38"-16NC x 1.50"	1
9	4831000061	Spacer	2
10	7950180000	Lockwasher, 0.59" ID	6
11	7950180153	Flatwasher, 0.50" ID	8
12	7115181250	Capscrew, 0.50"-13NC x 1.50"	2
13	7950160000	Lockwasher, 0.38" ID	4
14	7950160153	Flatwasher, 0.38" ID	4
15	7115161050	Capscrew, 0.38"-16NC x 1.25"	4
16	3679000012	Pad	2
17	7115180850	Capscrew, 0.50"-13NC x 1.00"	2
18	4706002828	Plate	1
19	4679000177	Pad	2
20	4679000176	Pad	2
21	7114140823	Capscrew, 0.25"-20NC x 1.00"	2
22	7115180750	Capscrew, 0.50"-13NC x 0.88"	4
23	4062000376	Bar	1
24	4706002899	Plate	2
25	7660162601	Locknut, 0.38"-16NC	4
26	7660182601	Locknut, 0.50"-13NC	2
27	7660160000	Nut, 0.38"-16NC	1
28	7660142604	Locknut, 0.25"-20NC	2
29	7115160650	Capscrew, 0.38"-16NC x 0.75"	4

WRECKER BOOM ASSEMBLY - 2 PIECE

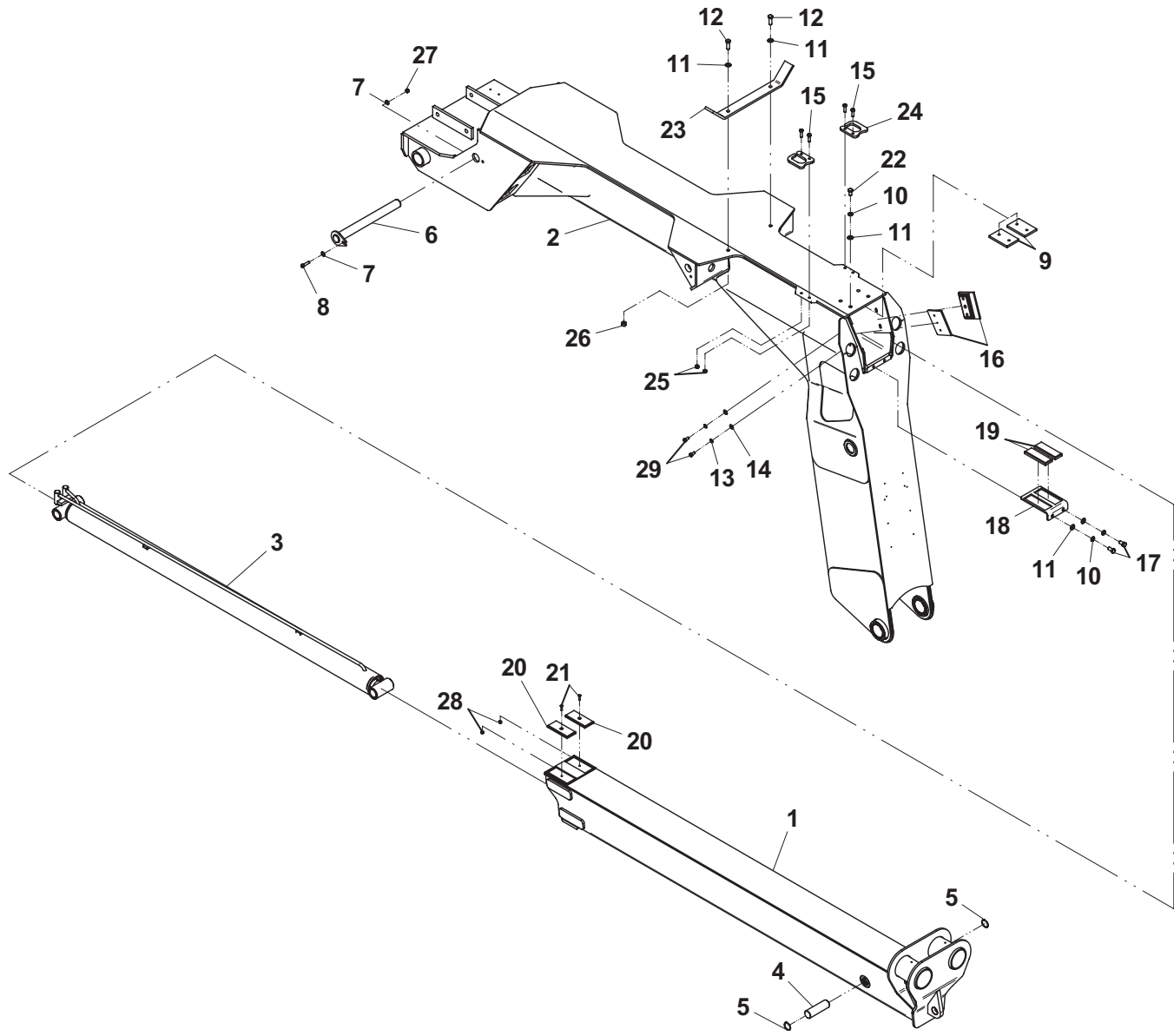

WRECKER BOOM EXTENSION CYLINDER ASSEMBLY - 3320000080

ITEM	PART NO.	DESCRIPTION	QTY
1	3071000074	Barrel Weldment	1
2	3763000094	Rod Weldment	1
3	7661000035	Locknut, 1.50"-12NF	1
4	7796000013*	Ring, Wear	2
5	7796000064*	Seal, Piston	1
6	4698000009*	Piston	1
7	7755226609*	Ring, Back-up	2
8	7755226000*	Seal, "O" Ring	1
9	7754000016	Retaining Ring	1
10	7755338000^	Seal, "O" Ring	1
11	7755338609^	Ring, Back-up	1
12	7754000012^	Ring, Wear	1
13	4553000010^	Head	1
14	7796000025^	Seal, Rod	1
15	7796000011^	Seal, Rod Wiper	1
16	7754000027	Retaining Ring	1
17	7440030000	Grease Fitting	1
18	7253000002	Cap, Grease Fitting	1

* Included in Piston Assembly, P/N 3698000004

^ Included in Head Assembly, P/N 3553000014

Service Seal Kit, P/N 7577250025

WRECKER BOOM EXTENSION CYLINDER ASSEMBLY - 3320000080

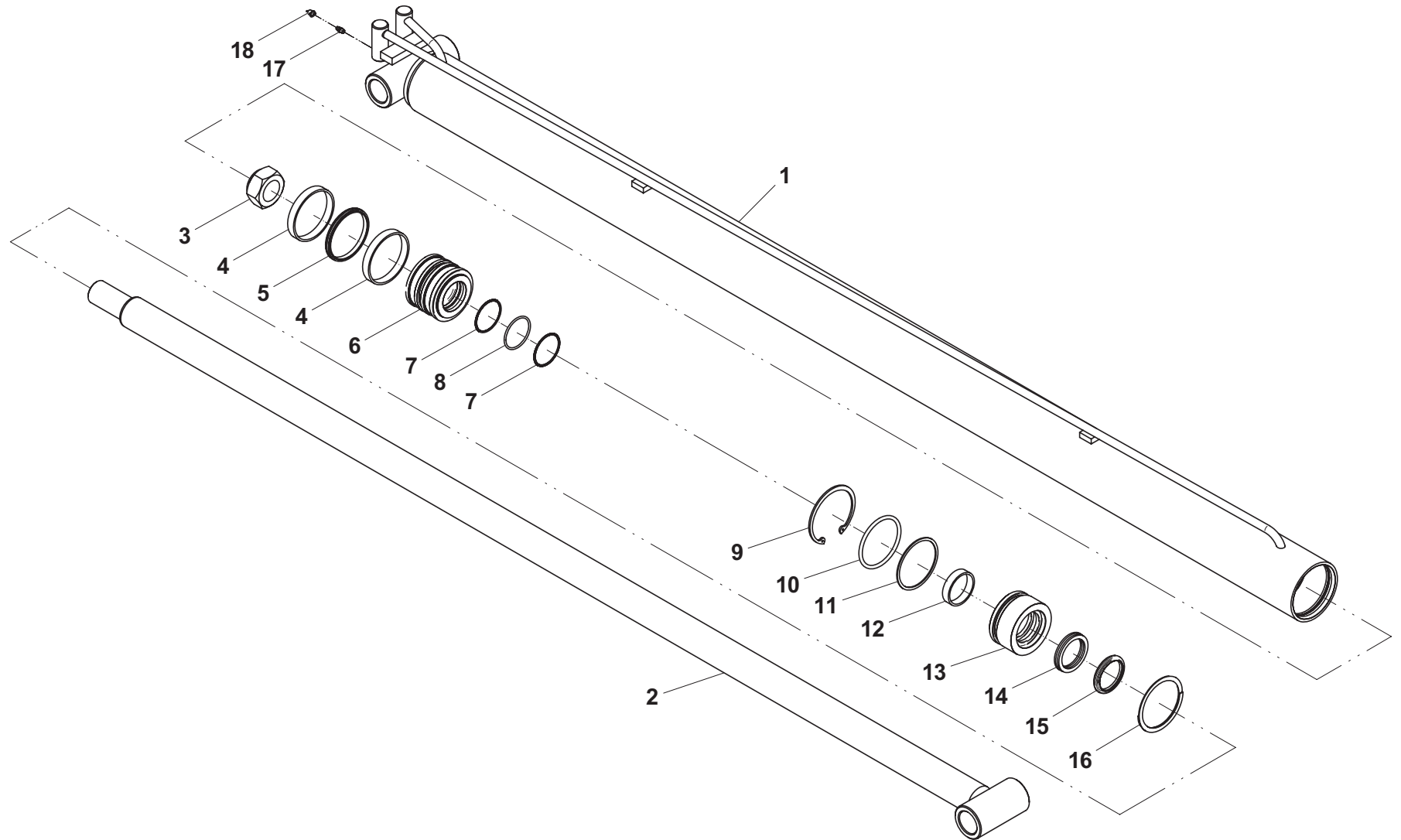

BOOM TUBE ASSEMBLY

ITEM	PART NO.	DESCRIPTION	QTY
1	7912000173*	Tube Assembly	4
2	1001131306	Clamp	6

* Available in Hydraulic Tubing Kit - 7577000681

BOOM TUBE ASSEMBLY

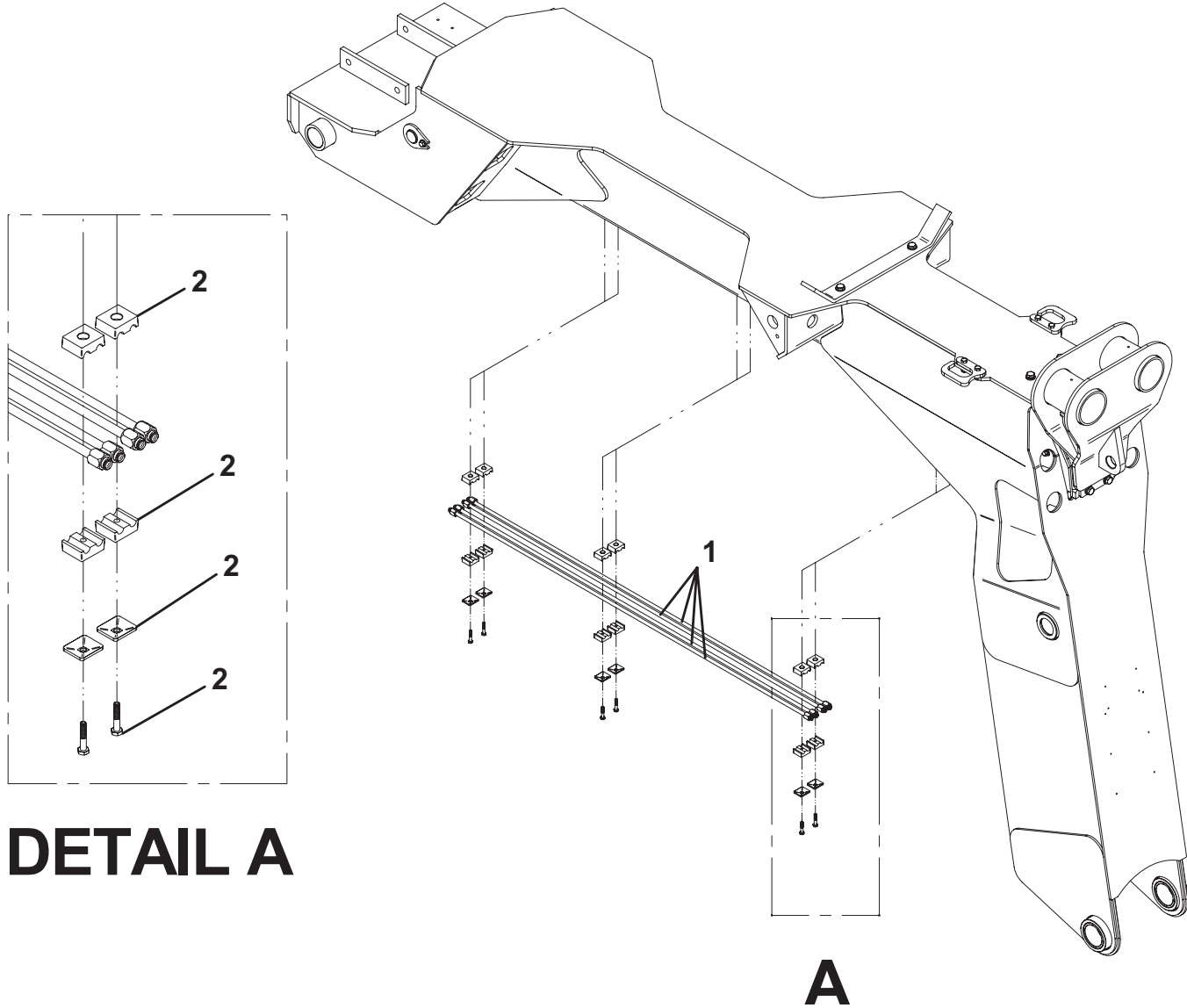

DETAIL A

WINCH INSTALLATION - 15K SUPERWINCH PLANETARY

ITEM	PART NO.	DESCRIPTION	QTY
1	3073000013	Bracket, Winch Mount	1
2	7970000080	Winch	2
3	7118201616	Capscrew, 0.63"-11NC x 2.00"	6
4	7661000018	Nut, 0.63"-11 NC	6
5	7118181216	Capscrew, 0.50"-13NC x 1.50"	16
6	7950180000	Lockwasher, 0.59" ID	16
7	3249000014	Weldment Cable Guide	2
8	3249000013	Sheave Support Weldment	2
9	7754000049	Retaining Ring	2
10	4249000003	Cable Guide	4
11	7115142050	Capscrew, 0.25"-20NC x 2.50"	4
12	7660142601	Locknut, 0.25"-20NC	4
13	3691000181	Pin	2
14	7440030000	Grease Fitting	4
15	7809000020	Sheave	2
16	7754000033	Retaining Ring	2
17	7253000002	Cap, Grease Fitting	4
18	7950180252	Flatwasher, 0.50" ID	4
19	4949000055*	Washer, 4.00" x 1.62" x 0.06"	4
20	4949000056*	Washer, 4.00" x 1.62" x 0.09"	4
21	7248000058	Cable, 0.50" x 150'	2
	7248000145	Cable, 0.50" x 150' w/ Swivel	2

* Also Available In Shim Kit - 3577000052

WINCH INSTALLATION - 15K SUPERWINCH PLANETARY

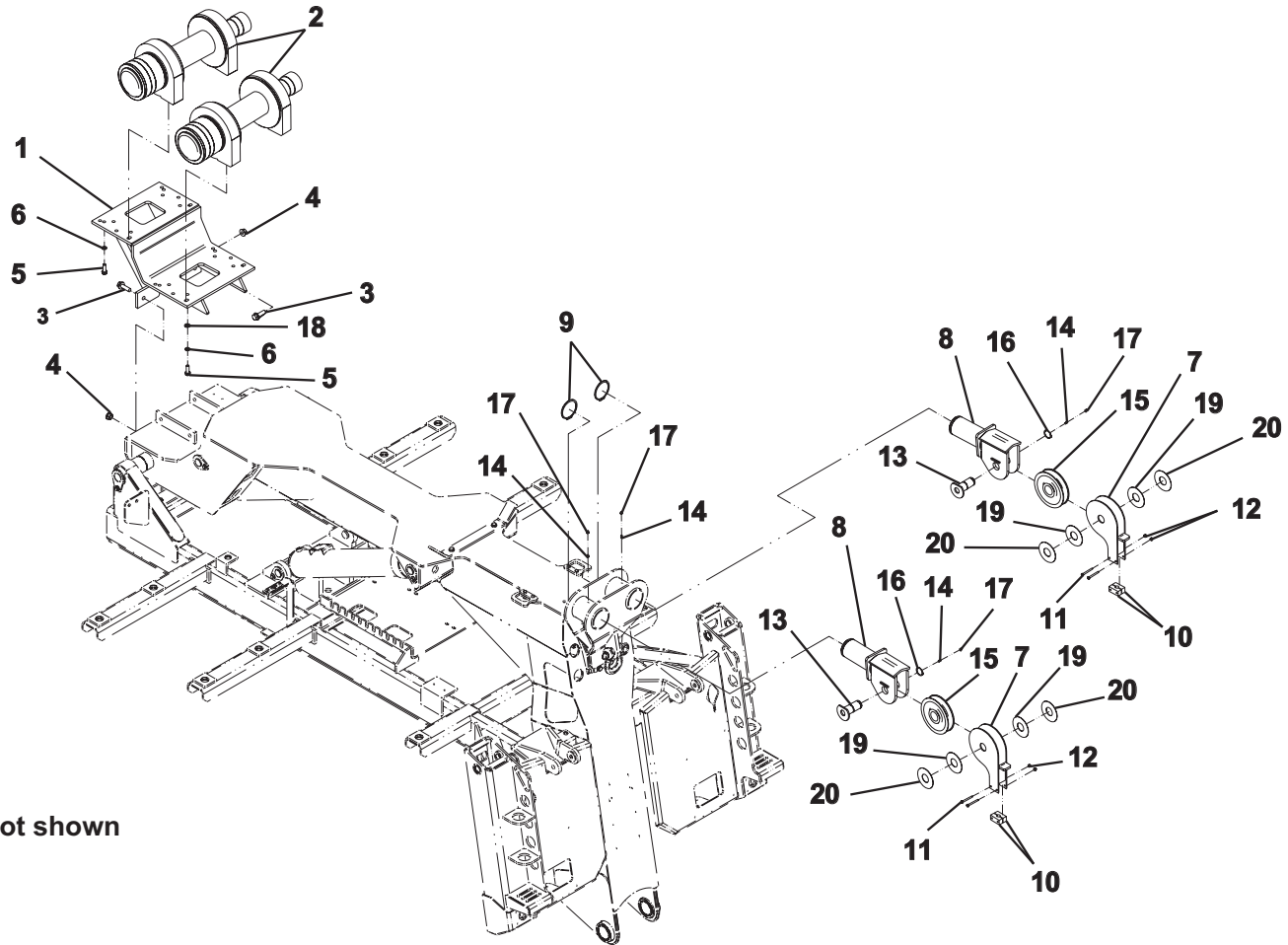

Item 21 not shown

WINCH 15K SUPERWINCH - 7970000080

ITEM	PART NO.	DESCRIPTION	QTY	ITEM	PART NO.	DESCRIPTION	QTY
1	9120960032	Bolt, Hex Head M8 x 150	6	35	9949960023	Washer, Rotor Thrust	1
2	9949960022	Lockwasher, M8	16	36	70050157	Plate, Stationary Disc	3
3	9314960019	Cover, Gearbox	1	37	9706960043	Plate, Rotating Disc	2
4	9679960003	Pad, Thrust 1st Stage	1	38	**	Seal, Brake Release 'U'	1
5	9472960047	Gear, Ring 1st Stage	1	39	70050158	Kit, Brake Repair	1
6	9472960045	Carrier, Assembly 1st Stage	1	40	9120960031	Bolt, Hex Head M8 x 40	8
7	9472960051	Gear, Sun 2nd Stage	1	41	9120960029	Bolt, Hex Head, 0.31"-18NC x 2.50"	4
8	9754960040	Ring, Gear Spacer	1	42	9949960019	Lockwasher, 0.31" ID	4
9	9472960050	Gear, Sun 1st Stage	1	43	9619960001	Manifold	1
10	9309960010	Coupling, Drive Shaft	1	44	9949960020	Motor, Hydraulic - H15P	1
11	9831960012	Spacer, Coupling	1	45	9472960049	Gear, Sliding Dog	1
12	9806960018	Shaft, Drive - 10"	1	46	70050159	Housing, Gear Box	1
13	9575960011	Key, 6mm x 6mm	1	47	9949960024	Washer, Thrust	2
14	9949960026	Washer, Thrust 2nd Stage	1	48	9796960103	Seal, 'O' Ring	1
15	9472960046	Carrier, Assembly 2nd Stage	1	49	9698960011	Piston, Freespool	1
16	9949960025	Washer, Thrust 2nd Carrier	1	50	9796960104	Seal, 'O' Ring	1
17	9843960031	Spring, Wave	1	51	9754960041	Ring, Retaining	1
18	9472960048	Gear, Ring 2nd Stage	1	52	9843960028	Spring	1
19	9691960023	Pin, Spring	3	NS	9443960004	Fitting, Bleed Nipple	1
20	9796960102	Seal, Carrier Body Oil	4	NS	9443960022	Fitting, Hydraulic	3
21	9831960013	Spacer, Ring Gear	1	NS	70050160	Hose Assembly	1
22	9843960030	Spring, Drag Button Tensioner	2				
23	9180960013	Tensioner, Drag Button	2				
24	9796960105	Seal, 'V' Face	2				
25	9082960017	Bearing, Drum	2				
26	9970960021	Drum, Assembly - 10"	1				
27	*	Screw, Socket Head Set M8 x 10	1				
28	9062960003	Bar, Tie - 10" Drum	2				
29	70050154	Bolt, M12 x 1.75-25mm	8				
30	70050155	Lockwasher, 12mm	8				
31	70050156	Housing, Brake	1				
32	9843960029	Spring, Disc	2				
33	9706960042	Plate, Pressure	1				
34	9180960012	Brake, Rotor	1				

* Purchase at Hardware Supplier

** Sold only with Item #39 - 70050158

WINCH - 15K SUPERWINCH - 7970000080

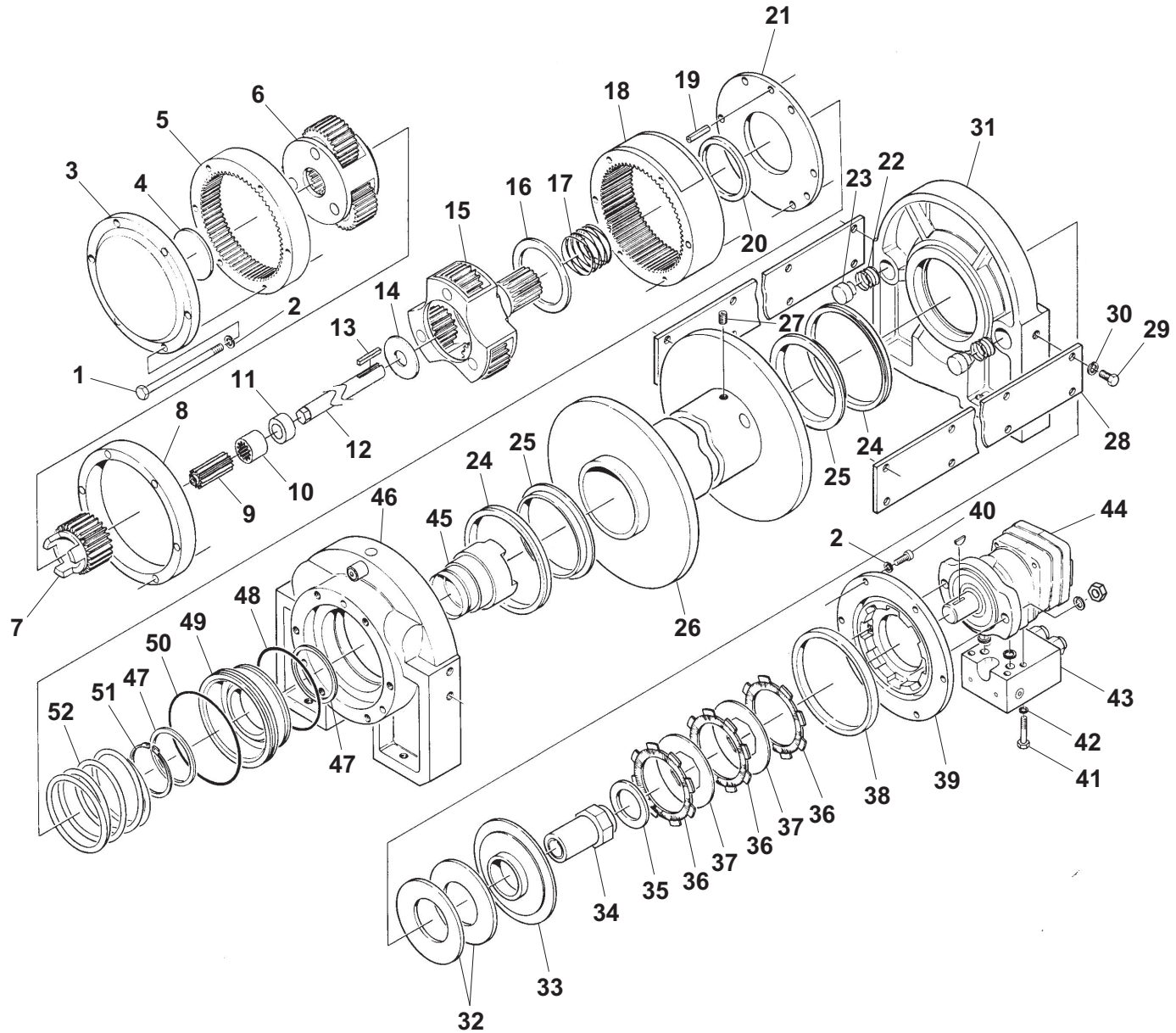

WINCH INSTALLATION - 15K DP PLANETARY

ITEM	PART NO.	DESCRIPTION	QTY
1	3073000013	Bracket, Winch Mount	1
2	7970000084	Winch	2
3	7118201616	Capscrew, 0.63"-11NC x 2.00"	6
4	7661000018	Nut, 0.63"-11NC	6
5	7118181250	Capscrew, 0.50"-13NC x 1.50"	8
6	7950180000	Lockwasher, 0.59" ID	12
7	7118181450	Capscrew, 0.50"-13NC x 1.75"	4
8	7950180252	Flatwasher, 0.50" ID	4
9	3249000014	Weldment Cable Guide	2
10	3249000013	Sheave Support Weldment	2
11	7754000049	Retaining Ring	2
12	4249000003	Cable Guide	4
13	7115142050	Capscrew, 0.25"-20NC x 2.50"	4
14	7660142601	Locknut, 0.25"-20NC	4
15	3691000181	Pin	2
16	7440030000	Grease Fitting	4
17	7253000002	Cap, Grease Fitting	4
18	7809000020	Sheave	2
19	7754000033	Retaining Ring	2
20	4949000053*	Washer, 4.00" x 1.81" x 0.06"	4
21	4949000054*	Washer, 4.00" x 1.81" x 0.09"	4
22	7248000058	Cable, 0.50" x 150'	2
	7248000145	Cable, 0.50" x 150' w/ Swivel	2

* Also Available In Shim Kit - 3577000052

WINCH INSTALLATION - 15K DP PLANETARY

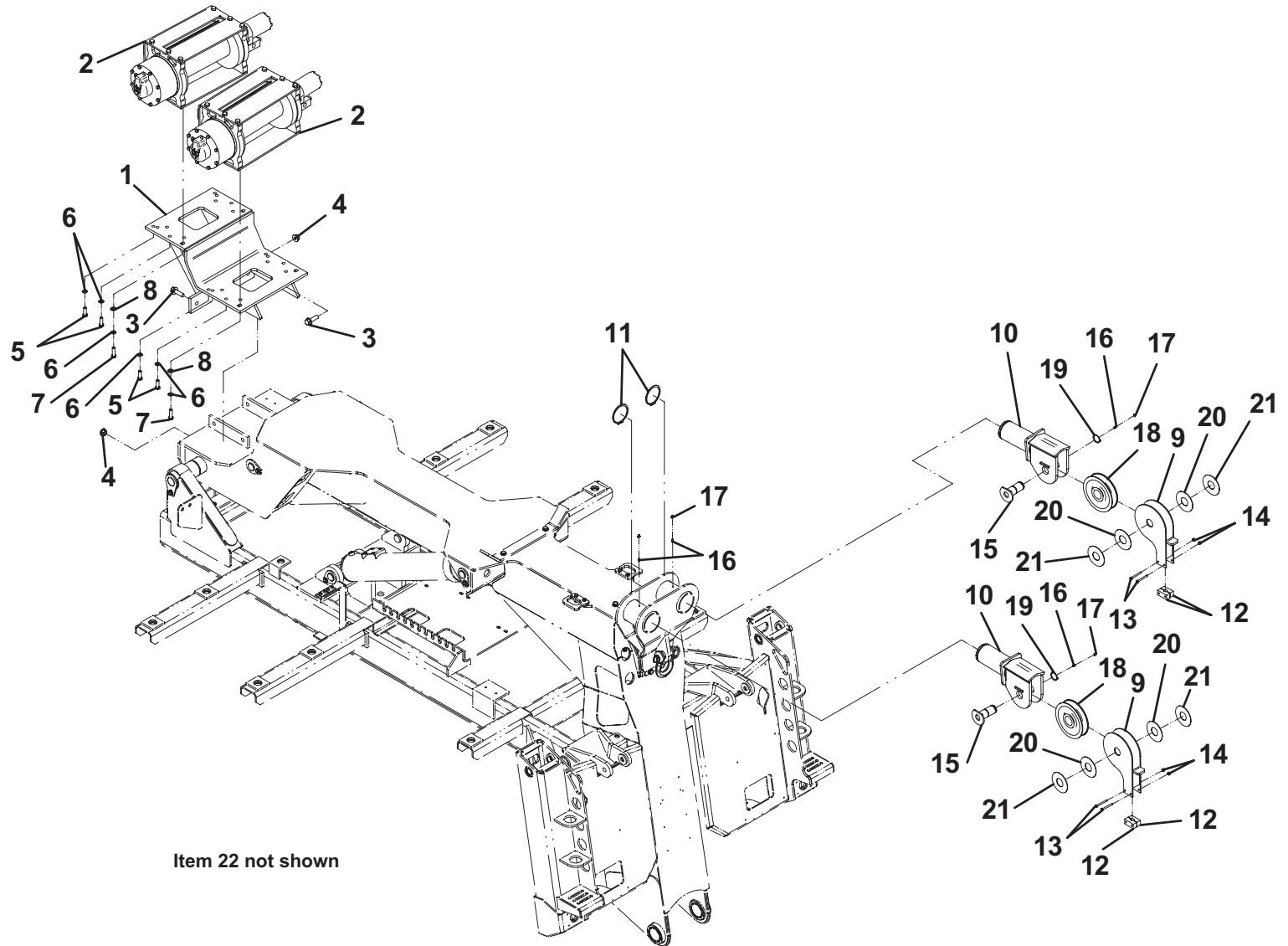

WINCH - 15K DP - 7970000084 - MOTOR END INSTALLATION

ITEM	PART NO.	DESCRIPTION	QTY
1	70050113	Motor, Hydraulic	1
2	70050114	Valve, Counterbalance	1
3	70050116	Housing, Brake	1
4	70050117	Support, Motor End	1
5	70050118	Seal, U Cup	1
6	70050119	Plate - Thrust - Brake	1
7	70050120	Spring - Belleville	2
8	70050121	Plate - Stationary - Brake	1
9	70050122	Plate - Friction - Brake	2
10	70050123	Pin, Spiral	2
11	70050124	Shaft - Brake	1
12	70050125	Shaft, O-Ring	1
13	70050126	Capscrew - SH - 0.25"-20NC x 4.50"	1
14	70050127	Capscrew - SH - 0.50"-13NC x 1.25"	2
15	7950180800	Lockwasher - Hi Collar - 0.50" ID	2
16	70050128	Capscrew - 0.50"-13NC x 2.00"	4
17	70050129	Cartridge	1
18	70050130	Retaining Ring	1
19	70050131	Capscrew - SH - 0.31"-18NC x 1.50"	4
20	9796960145	Seal, O-Ring	1
21	7950180000	Lockwasher, 0.50" ID	4
22	70050132	Plug	1
23	9796960146*	Seal, O-Ring	2
24	70050115*	Seal, O-Ring	1

* Available Only In Kit - 70050133

WINCH - 15K DP - 7970000084 - MOTOR END INSTALLATION

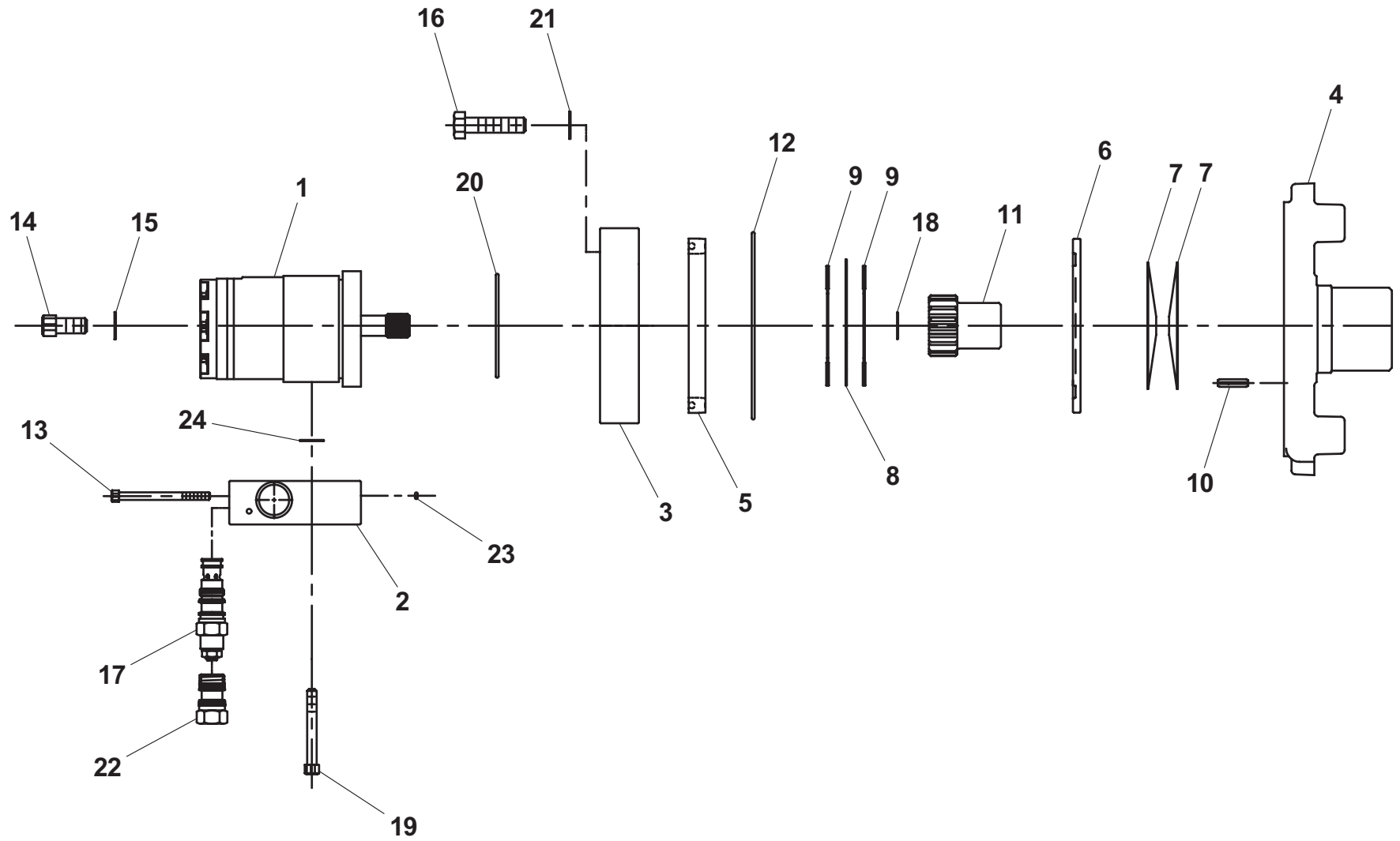

WINCH - 15K DP - 7970000084 - DRUM INSTALLATION

ITEM	PART NO.	DESCRIPTION	QTY
1	70050134	Drum	1
2	70050135	Set Screw,SH, 0.38-16NC x 1.25"	2
3	70050136	Bearing, Bronze	2
4	70050137	Seal	2

WINCH - 15K DP - 7970000084 - DRUM INSTALLATION

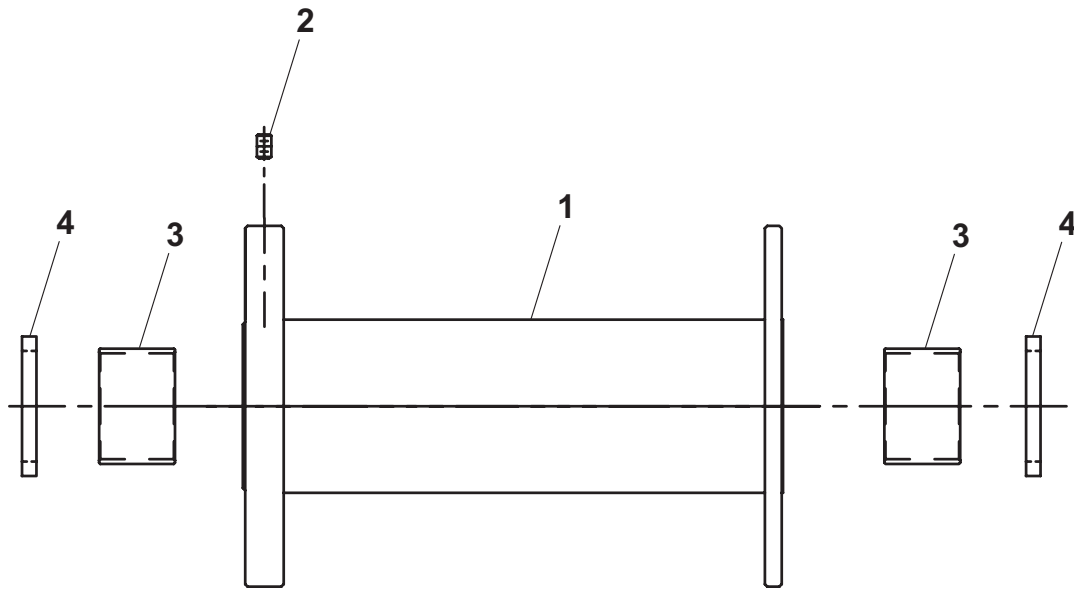

WINCH - 15K DP - 7970000084 - GEAR END INSTALLATION

ITEM	PART NO.	DESCRIPTION	QTY
1	70050138	Support - Gear - End	1
2	70050139	Gear - Ring	1
3	70050068	Cover, Gearbox	1
4	70050140	Gear - Sun- Secondary	1
5	9831960028	Spacer - Gear Ring	1
6	9949000056	Washer - Thrust - Nylon	2
7	9796960188	Seal, O-Ring	2
8	70050141	Carrier - Assembly - Primary	1
9	9949960057	Washer - Thrust	2

WINCH - 15K DP - 7970000084 - GEAR END INSTALLATION

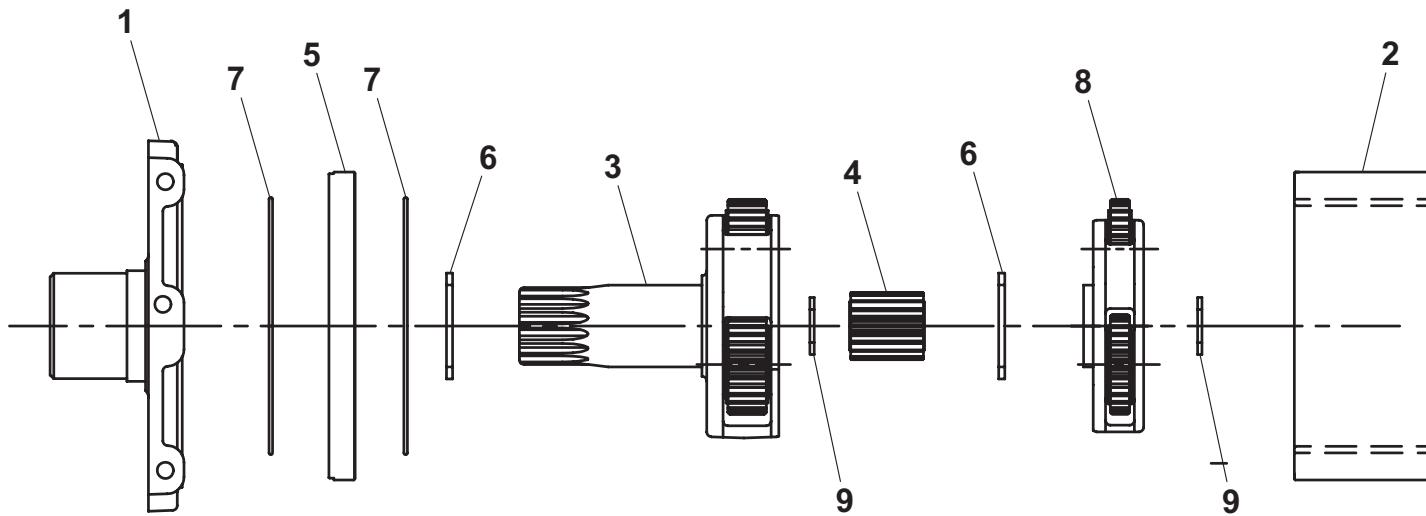

WINCH - 15K DP - 7970000084 - INPUT SHAFT INSTALLATION

ITEM	PART NO.	DESCRIPTION	QTY
1	70050142	Shaft	1

WINCH - 15K DP - 7970000084 - INPUT SHAFT INSTALLATION

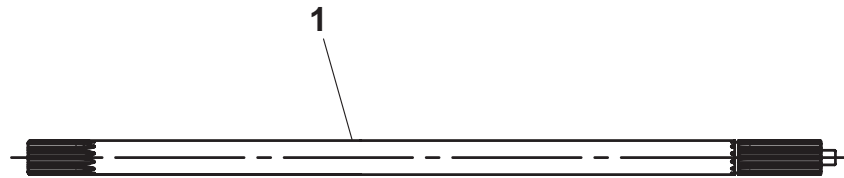

WINCH - 15K DP - 7970000084 - BASE MOUNT INSTALLATION

ITEM	PART NO.	DESCRIPTION	QTY
1	70050004	Arm - Cable Holddown-15J-Underwound	1
2	70050143	Spacer-Arm-Cable Hold down	1
3	70050144	Spring-Torsion-LH	1
4	70050005	Shaft- Pivot-Cable Hold down	1
5	70050145	Spring-Torsion-RH	1
6	70050146	Retaining Ring	2
7	70050149	Base Mount	1
8	70050150	Spacer	1
9	70050147	Rivet - Drive - U Type - #2	4
10	70050148	Plate, ID	1

WINCH - 15K DP - 7970000084 - BASE MOUNT INSTALLATION

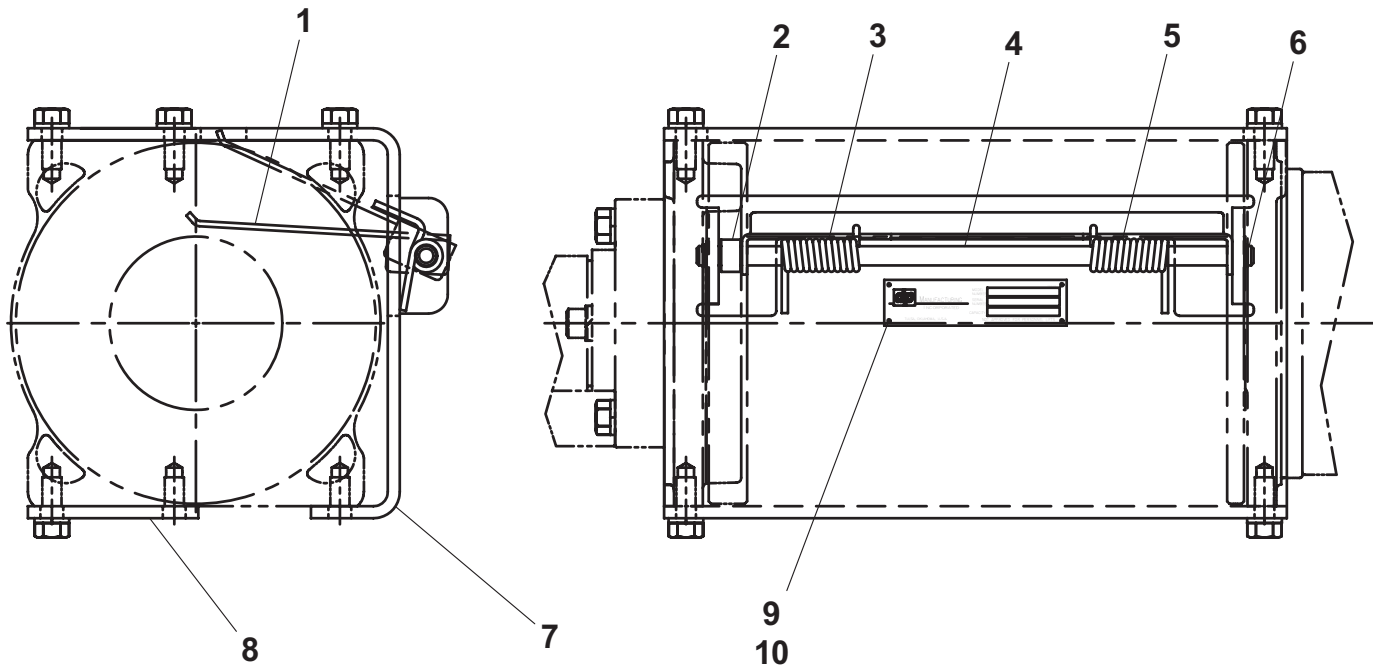

WINCH - 15K DP - 7970000084 - GEAR END COVER INSTALLATION

ITEM	PART NO.	DESCRIPTION	QTY
1	70050151	Cover - Gear End	1
2	70050085	Coupling - Drive	1
3	70050086	Piston	1
4	70050152	Gear - Sun	1
5	9698960015	Cylinder - Piston	1
6	9754960026	Retaining Ring	1
7	9843960032	Spring, Compression	1
8	9209960026	Bushing, Bronze	1
9	9754960046	Retaining Ring	1
10	9754960047	Retaining Ring	1
11	9796960119	Seal, O-Ring	2
12	9796960118	Seal, O-Ring	1
13	9701960012	Plug, Magnetic	1
14	9701960011	Plug	1
15	70050153	Capscrew, 0.31"-18NC x 5.50"	8
16	9949960050	Lockwasher, 0.31" ID	8
17	9796960188	Seal, O-Ring	1
18	9183960001	Vent	1

WINCH - 15K DP - 7970000084 - GEAR END COVER INSTALLATION

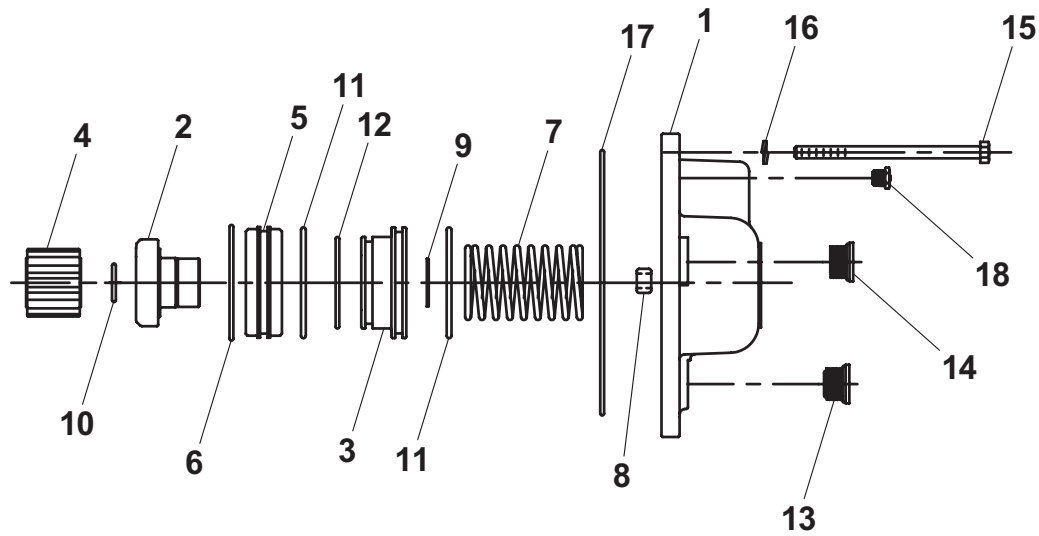

WINCH AIR SHIFT

ITEM	PART NO.	DESCRIPTION	QTY	ITEM	PART NO.	DESCRIPTION	QTY
		2504630020 - SUPERWINCH				2504630092 - 15K DP WINCH	
1	7443000154	Bushing	1	1	7443000154	Bushing	1
2	7443000155	Elbow	1	2	7443000155	Elbow	1
3	7443000156	Nipple	2	3	7443000156	Nipple	2
4	7443000152	Plug	1	4	7443000152	Plug	1
5	7443000139	Fitting	2	5	7443000139	Fitting	2
6	7443000138	Fitting	2	6	7443000138	Fitting	2
7	7935000120	Pressure Valve	1	7	7935000120	Pressure Valve	1
8	7443000175	Fitting	2	8	7443000175	Fitting	2
9	7443000149	Bushing	1	9	7443000149	Bushing	1
10	7443000173	Fitting	4	10	7443000173	Fitting	4
11	7950140161	Flatwasher, 0.25" ID	2	11	N/A		
12	7446502518	Fitting	1	12	7446502518	Fitting	1
13	7312000017	Quick Disconnect	1	13	7312000017	Quick Disconnect	1
14	7565000016	Airline Tubing, 0.25" OD	75ft	14	7565000016	Airline Tubing, 0.25" OD	75ft
15	7565000014	Airline Tubing, 0.38" OD	25ft	15	7565000014	Airline Tubing, 0.38" OD	25ft
16	7894000031	Cable Tie	6	16	7894000031	Cable Tie	6
17	7470000006	Air Pressure Gauge	1	17	7470000006	Air Pressure Gauge	1
18	7443000177	Fitting	2	18	N/A		
19	7935000136	Valve	2	19	7935000136	Valve	2
20	7443000243	Fitting	1	20	7443000243	Fitting	1
21	7295000029	Air Regulator	1	21	7295000029	Air Regulator	1
22	7443000243	Fitting	2	22	7443000243	Fitting	2
23	7493000011	Grommet	1	23	7493000011	Grommet	1
24	7330000210	Decal	1	24	7330000210	Decal	1

WINCH AIR SHIFT

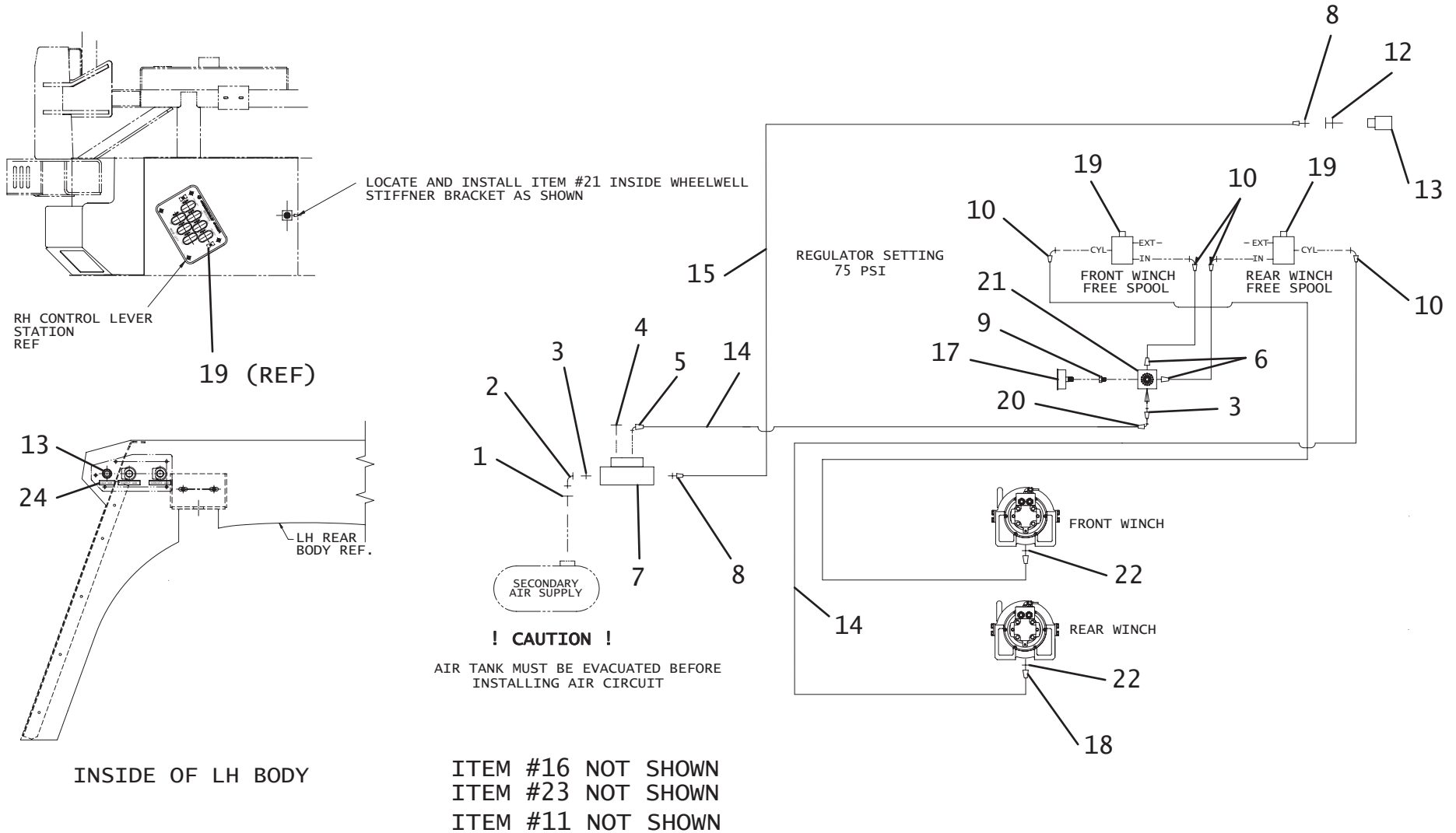

UNDERLIFT INSTALLATION

ITEM	PART NO.	DESCRIPTION	QTY
1	3170000294	Underlift Assembly	1
2	3320000139	Underlift Tilt Cylinder Assembly	1
3	4691000432	Pin	1
4	4691000433	Pin	1
5	7754000061	Retaining Ring	4
6	7440030000	Grease Fitting	9
7	7253000002	Cap, Grease Fitting	9
8	4691000434	Pin	1
9	7754000005	Retaining Ring	2
10	7209000050	Bushing	2

UNDERLIFT INSTALLATION

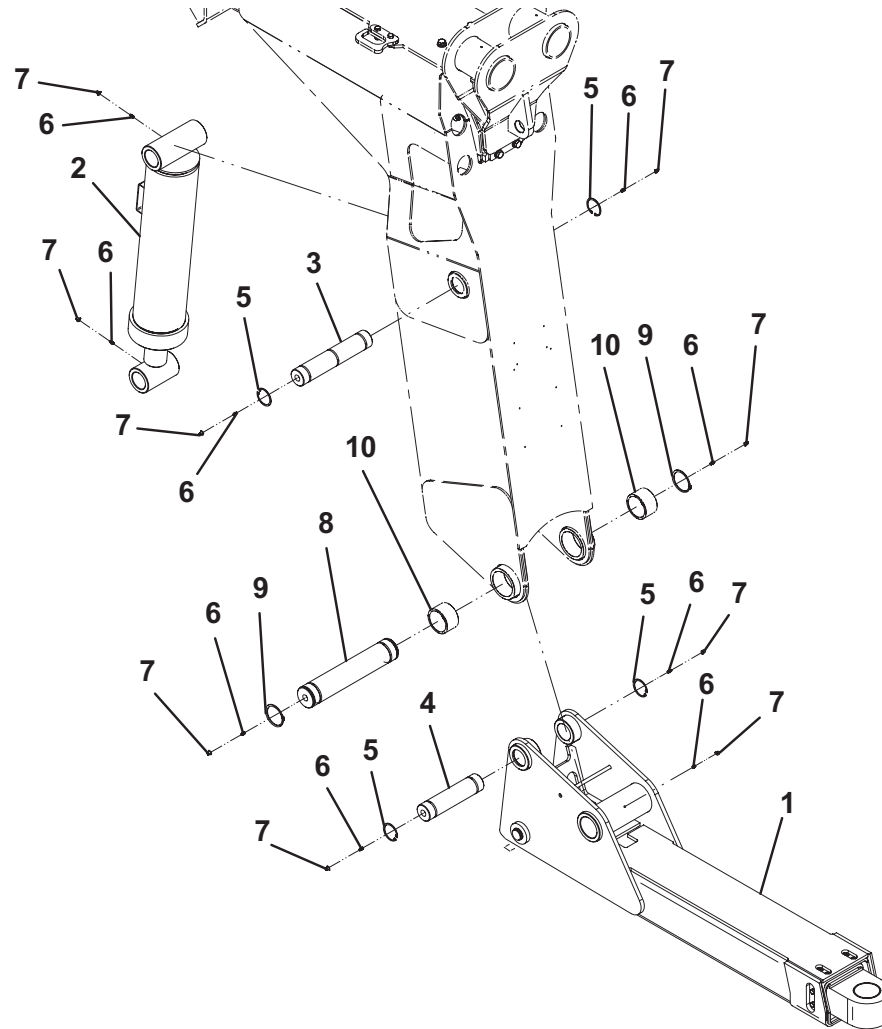

UNDERLIFT TILT CYLINDER ASSEMBLY - 3320000139

ITEM	PART NO.	DESCRIPTION	QTY
1	3071000112	Barrel Weldment	1
2	3763000124	Rod Weldment	1
3	7661000035	Locknut, 1.50"-12NF	1
4	7754000077*	Ring, Wear	2
5	7796000087*	Seal, Piston	1
6	4698000021*	Piston	1
7	7755230609*	Ring, Back-up	2
8	7755230000*	Seal, "O" Ring	1
9	7755350000^	Seal, "O" Ring	1
10	7755350609^	Ring, Back-up	1
11	7754000063^	Ring, Wear	1
12	4553000020^	Head	1
13	7796000058^	Seal, Rod	1
14	7796000059^	Seal, Rod Wiper	1
15	4254000016	Cap	1

* Included in Piston Assembly, P/N 3698000013

^ Included in Head Assembly, P/N 3553000021

Service Seal Kit, P/N 7577000327

UNDERLIFT TILT CYLINDER ASSEMBLY - 3320000139

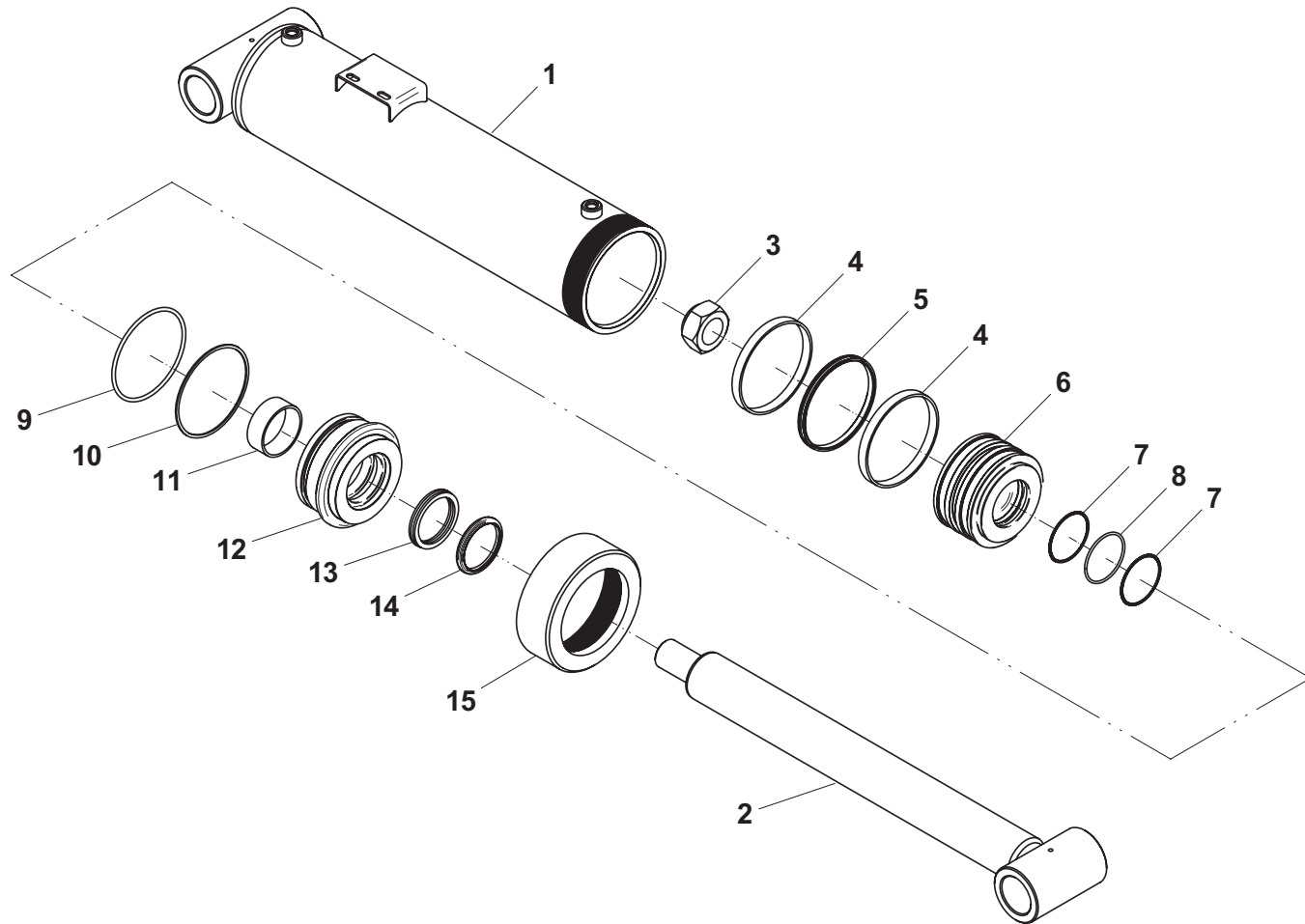

UNDERLIFT ASSEMBLY - 3170000294

ITEM	PART NO.	DESCRIPTION	QTY
1	3170000289	Base Section Boom Weldment	1
2	3170000187	Fly Section Boom Weldment	1
3	3320000072	Underlift Extension Cylinder Assembly	1
4	4691000329	Pin	1
5	4691000330	Pin	1
6	4679000175	Pad	2
7	7950140000	Lockwasher, 0.25" ID	4
8	4679000173	Pad	1
9	7754000062	Retaining Ring	2
10	7754000006	Retaining Ring	2
11	4679000174	Pad	2
12	7950150000	Flatwasher, 0.31" ID	4
13	7118140423	Capscrew, 0.25"-20NC x 0.50"	4
14	7118140527	Capscrew, 0.25"-20NC x 0.63"	4
15	7950140161	Flatwasher, 0.25" ID	4
16	7105150450	Capscrew, 0.31"-24NF x 0.50"	4
17	4831000071	Spacer	2
18	4209000019	Bushing	2

UNDERLIFT ASSEMBLY - 3170000294

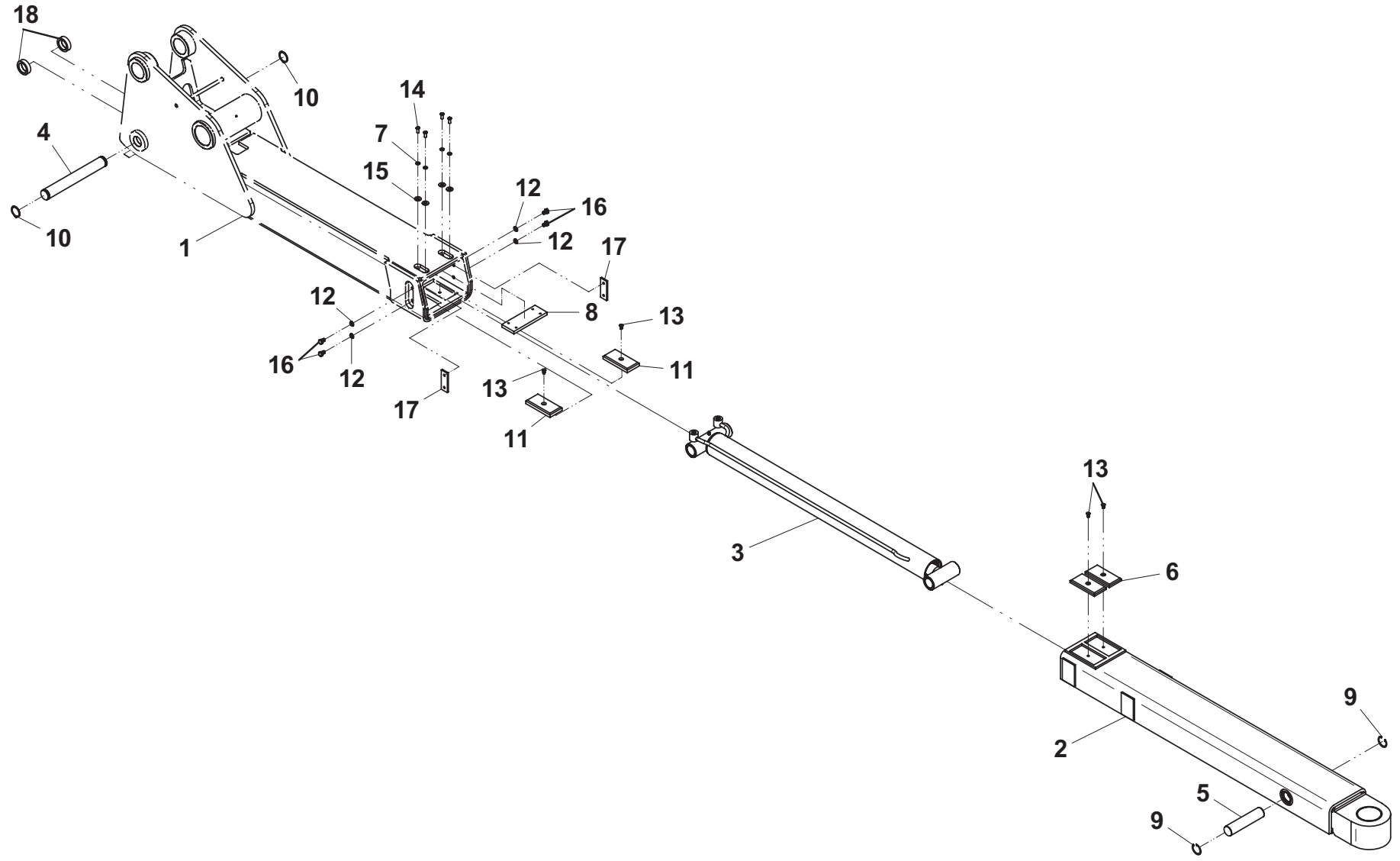

UNDERLIFT EXTENSION CYLINDER ASSEMBLY - 3320000072

ITEM	PART NO.	DESCRIPTION	QTY
1	3071000071	Barrel Weldment	1
2	3763000089	Rod Weldment	1
3	7661000034	Locknut, 1.00"-14NF	1
4	7754000053*	Ring, Wear	2
5	7796000067*	Seal, Piston	1
6	4698000015*	Piston	1
7	7755222609*	Ring, Back-up	2
8	7755222000*	Seal, "O" Ring	1
9	7754000051	Retaining Ring	2
10	7755330000^	Seal, "O" Ring	1
11	7755330609^	Ring, Back-up	1
12	4553000016^	Head	1
13	7754000054^	Ring, Wear	1
14	7796000045^	Seal, Rod	1
15	7796000046^	Seal, Rod Wiper	1
16	7440030000	Grease Fitting	2
17	7253000002	Cap, Grease Fitting	2

* Included in Piston Assembly, P/N 3698000006

^ Included in Head Assembly, P/N 3553000016

Service Seal Kit, P/N 7577250206

UNDERLIFT EXTENSION CYLINDER ASSEMBLY - 3320000072

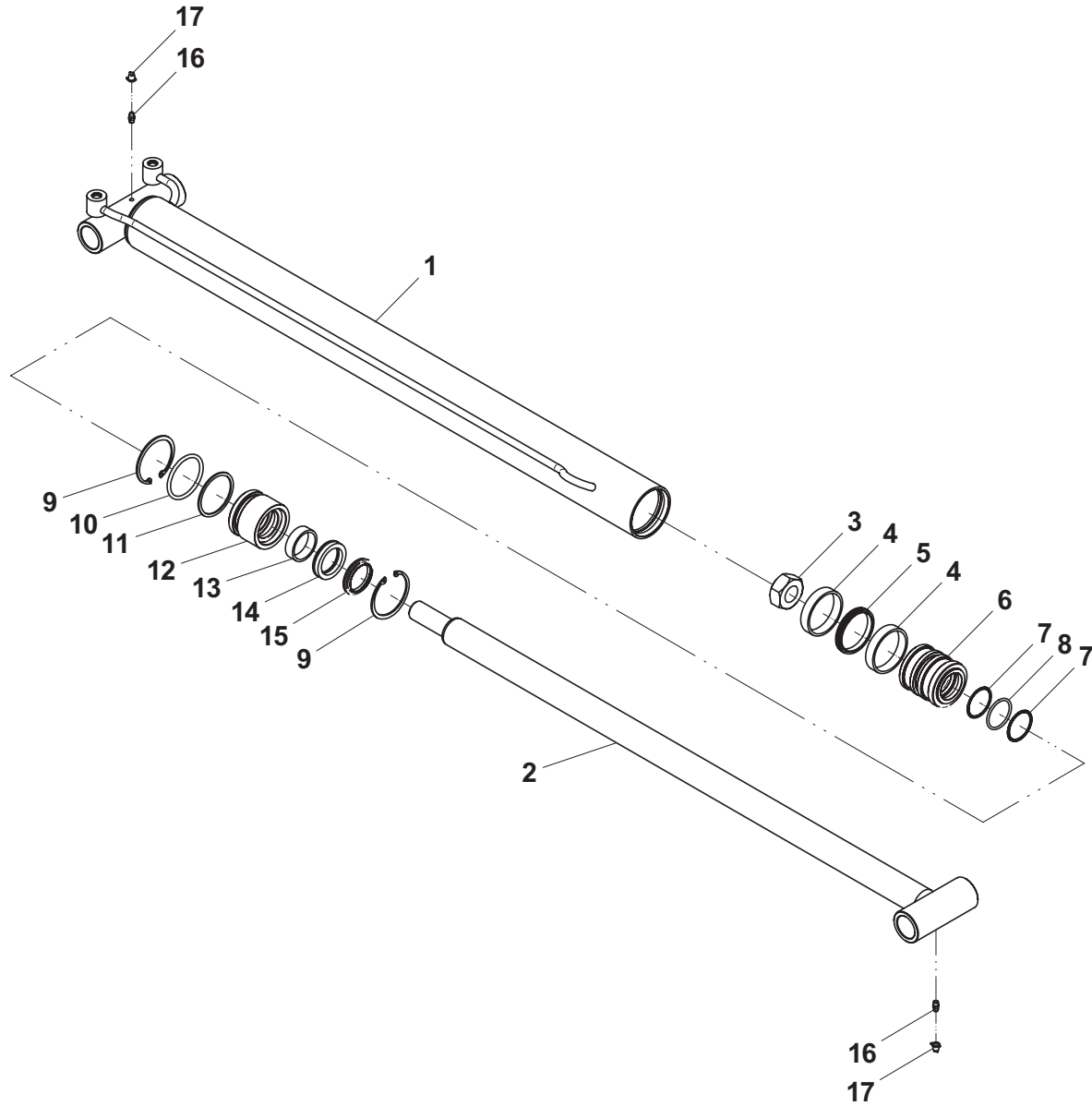

CROSSTUBE INSTALLATION

ITEM	PART NO.	DESCRIPTION	QTY
1	3913000064	Crosstube Weldment	1
2	4691000103	Pin	1
3	4949000047	Washer 5.00" OD x 2.84" ID x 0.063"	2
4	7754000024	Retaining Ring	1
5	7209000028	Connex Bushing	1
6	7440030000	Grease Fitting	1
7	7253000002	Cap, Grease Fitting	1

CROSTUBE INSTALLATION

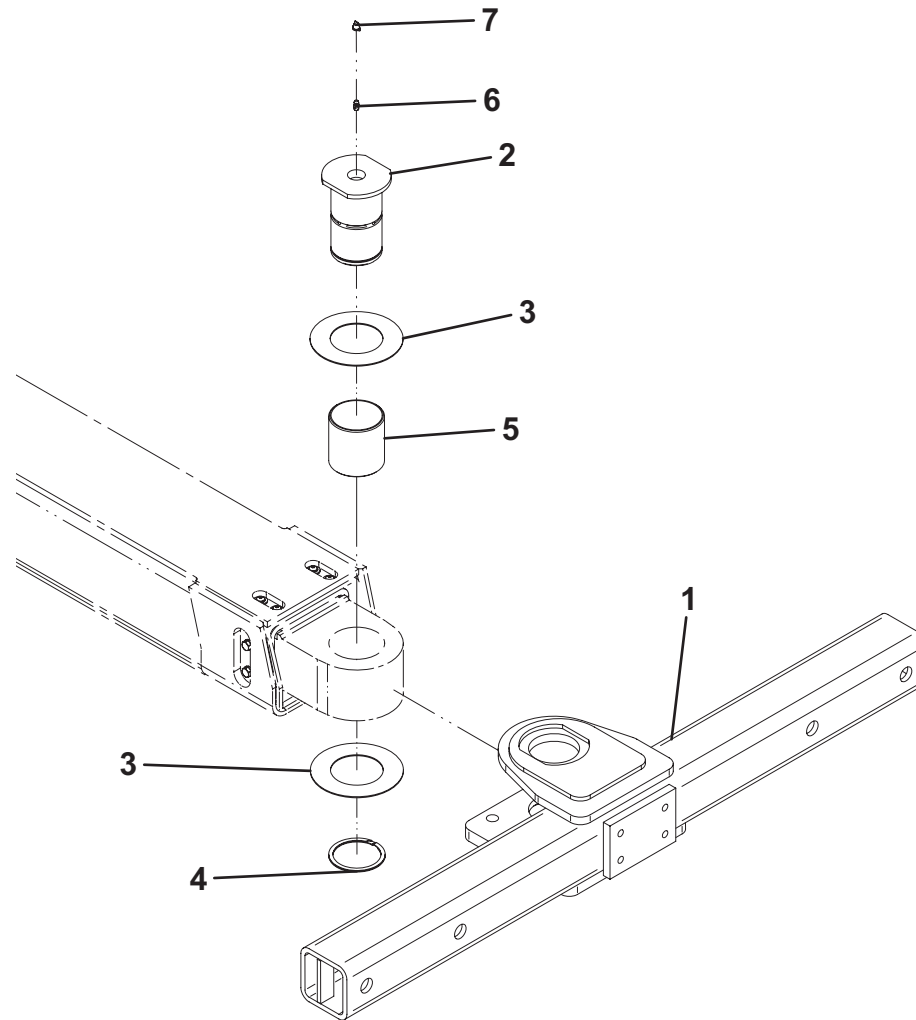

UNDERLIFT TOOLS - FRAME FORKS

ITEM	PART NO.	DESCRIPTION	QTY
1	7007000058	Adapter, Frame Fork - RH	1
2	7007000057	Adapter, Frame Fork - LH	1
3	3178000226	Spring Lift Bracket	2
4	7454000003	Fork, 4.50" Medium	2
5	7454000004	Fork, 4.50" Long	2
6	7454000005	Fork, 3.00" Medium	2
7	7454000006	Fork, 3.00" Short	2
8	7691000021	Hitch Pin	2
9	7691000031	Hitch Pin	2
10	7262000026	Chain, Tie-Down	2
11	3551000036	Handle	2

UNDERLIFT TOOLS - FRAME FORKS

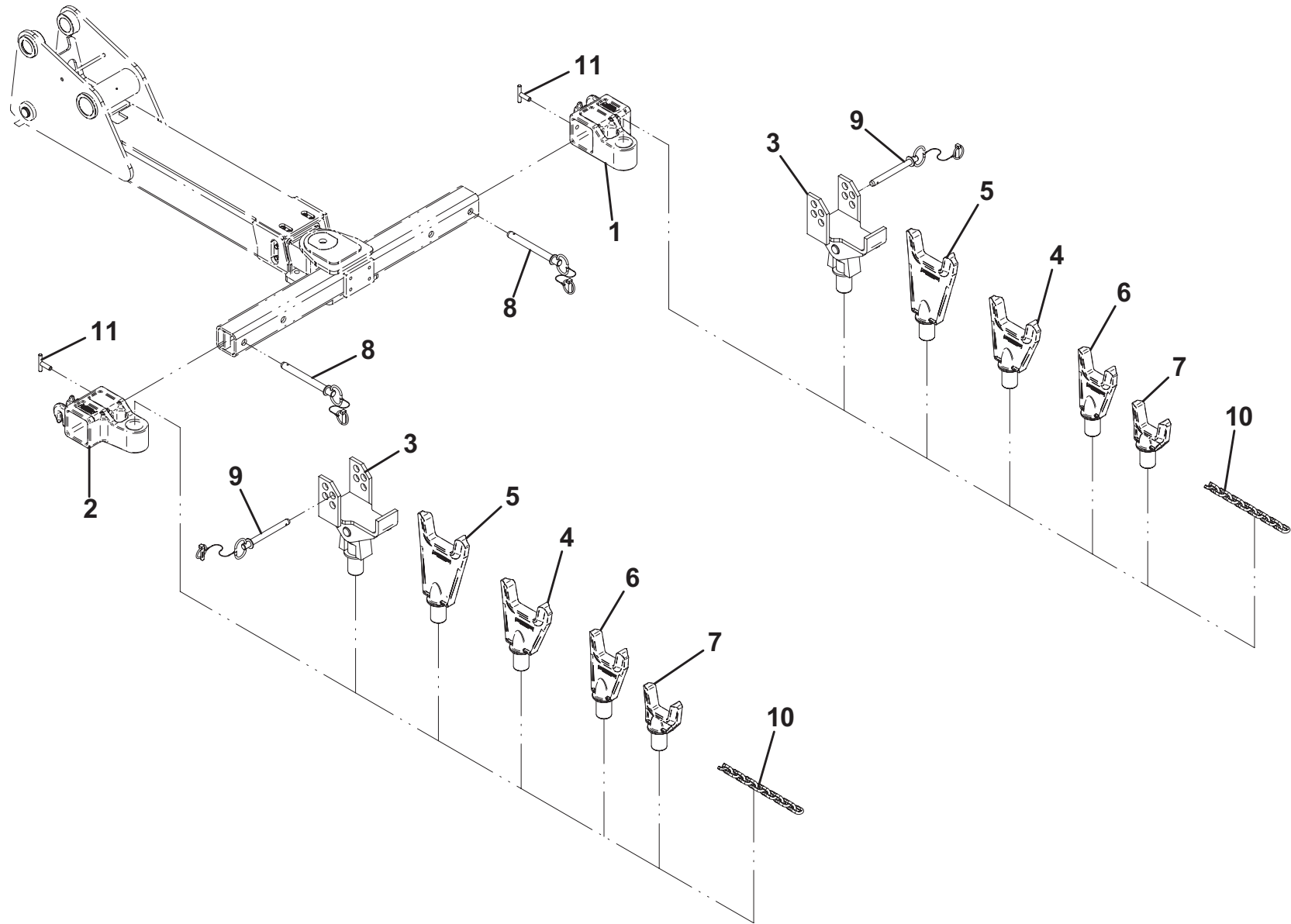

UNDERLIFT TOOLS - L-ARM ASSEMBLY - 2504880010

ITEM	PART NO.	DESCRIPTION	QTY
1	3484000041	Tire Grid Weldment - LH	1
2	3484000040	Tire Grid Weldment - RH	1
3	7894000034	Ratchet Strap 2" Wide	2
4	3551000036	Handle	2
5	3020000037	L-Arm Weldment - LH	1
6	3020000038	L-Arm Weldment - RH	1

UNDERLIFT TOOLS - L-ARM ASSEMBLY - 2504880010

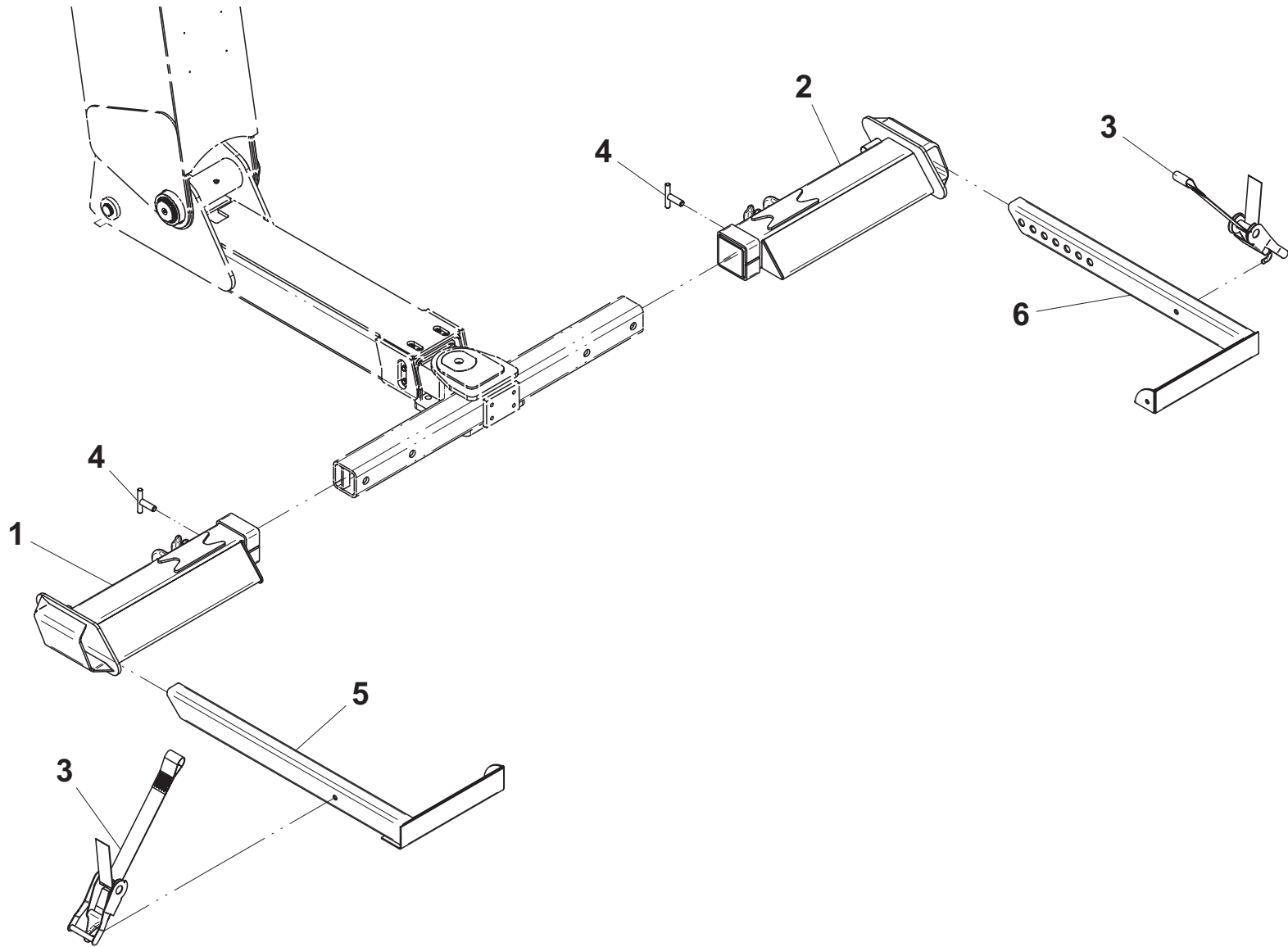

UNDERLIFT TOOLS - MEDIUM DUTY TIRE LIFT - 2504880009

ITEM	PART NO.	DESCRIPTION	QTY
1	3484000036	Tire Lift Grid - RH	1
2	3484000037	Tire Lift Grid - LH	1
3	3020000060	Tire Lift Arm Weldment - RH	1
4	3020000059	Tire Lift Arm Weldment - LH	1
5	3912000011	Tire Lift Tube Weldment	2
6	3561000011	Hook, 2" Wide Strap	4
7	4561000012	Hook, Pull	1
8	7894000041	Strap, 2" Wide	2
9	7894000028	Ratchet, 2" Wide Strap	4
10	4691000356	Pin	2
11	7691000030	Hitch Pin	2
12	7691000031	Hitch Pin	2
13	7691000020	Hairpin	2
14	7330000325	Decal	2
15	7330000324	Decal	2
16	7759000004	Rivet	8

* Also available as - 2503880009

UNDERLIFT TOOLS - MEDIUM DUTY TIRE LIFT - 2504880009

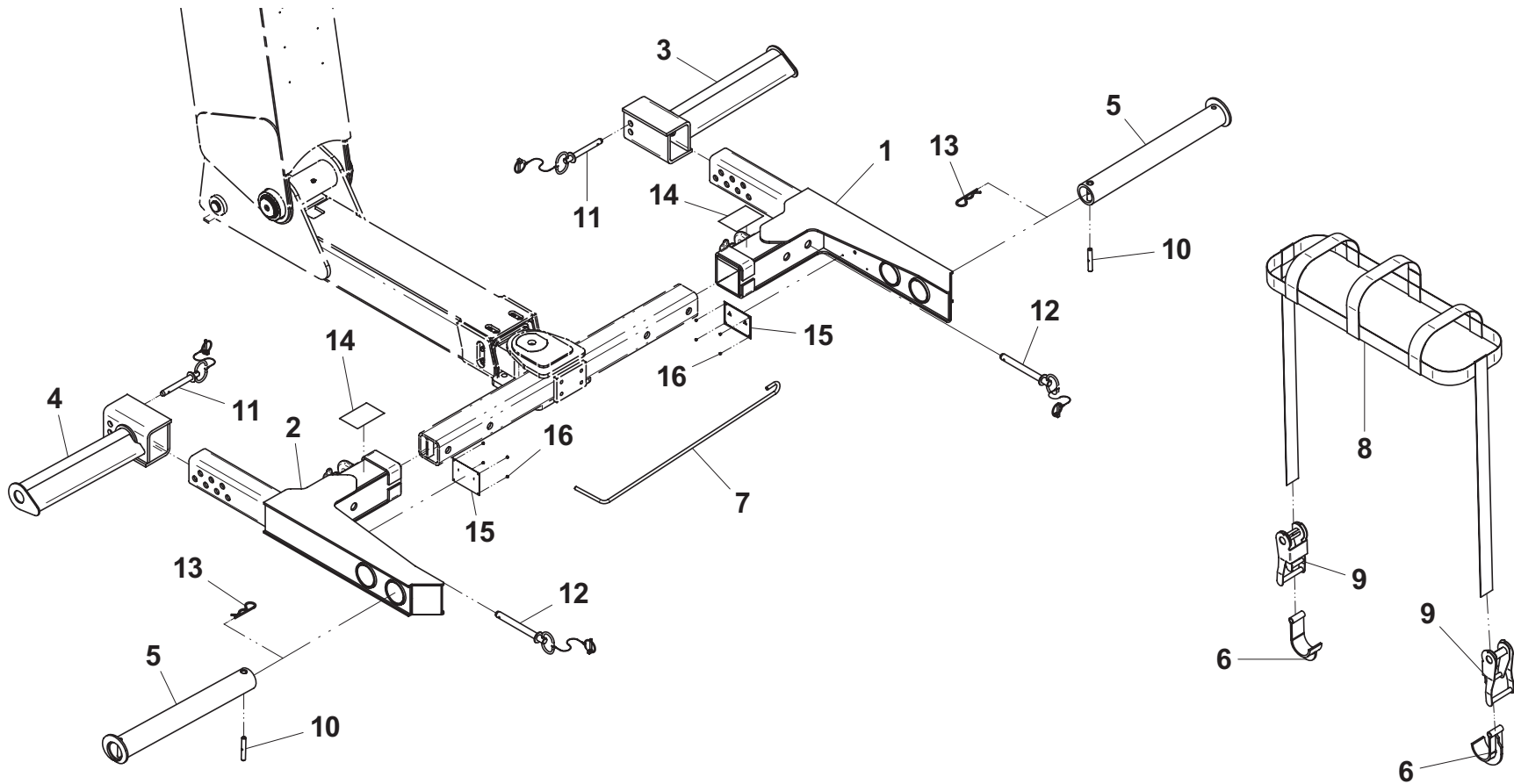

UNDERLIFT TOOLS - FIFTH WHEEL ATTACHMENT - 2503880077

ITEM	PART NO.	DESCRIPTION	QTY
1	3178000426*	Bracket Weldment	1
2	3178000499*	Bracket, Fifth Wheel Weldment	1
3	3706000311*	Plate Weldment	1
4	3691000144*	Pin	1
5	3691000145*	Pin	1
6	7118265650*	Capscrew, 1.00"-8NC x 7.00"	2
7	7118221650*	Capscrew, 0.75"-10NC x 2.00"	2
8	7691000025*	Pin	2

* Also available as - 2503880077

UNDERLIFT TOOLS - FIFTH WHEEL ATTACHMENT - 2503880077

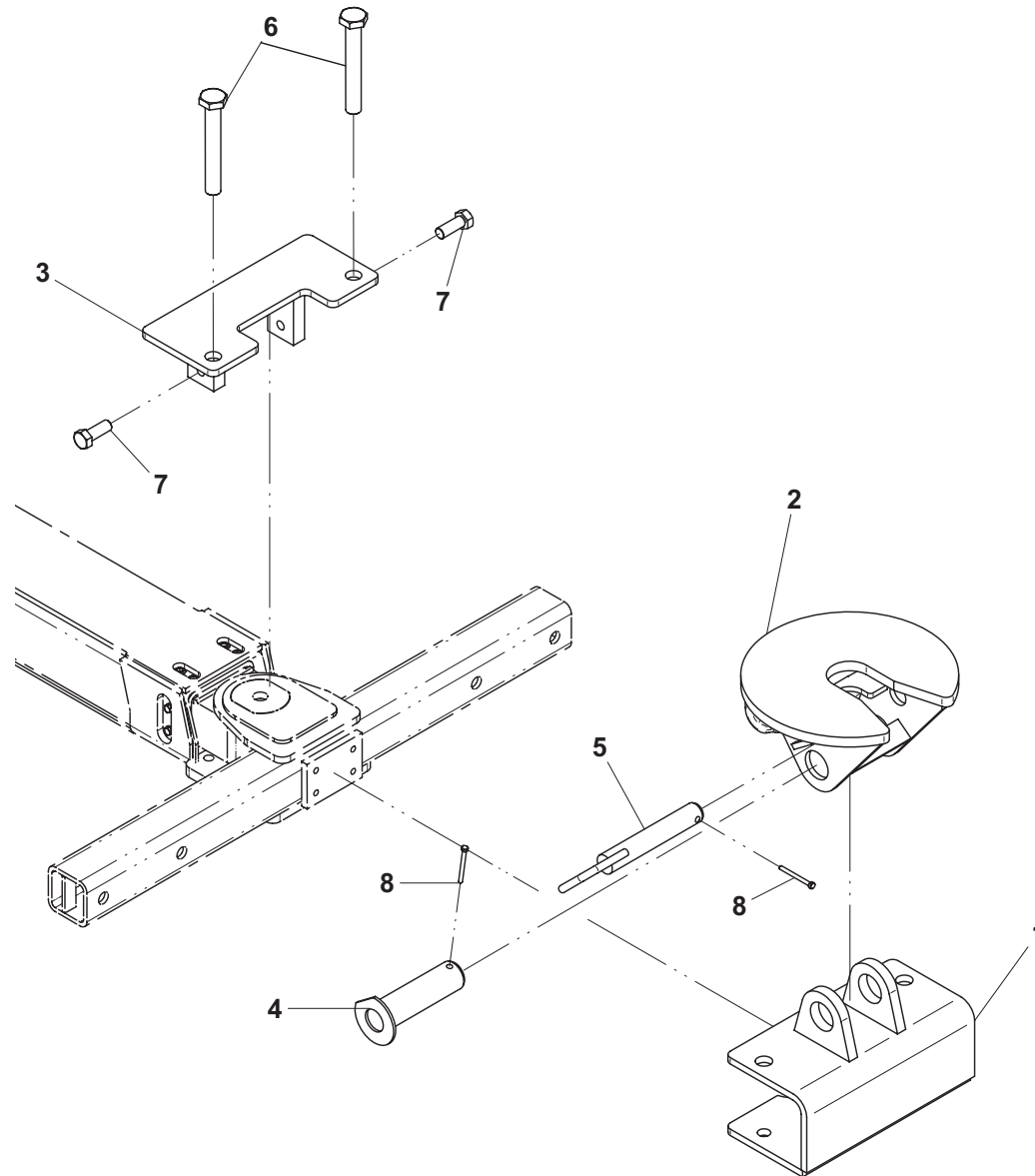

UNDERLIFT TOOLS - BALL HITCH

ITEM	PART NO.	DESCRIPTION	QTY
1	7056000007	Chrome Ball, 1.88" Dia.	1
	7056000008	Chrome Ball, 2.00" Dia.	1
	7056000009	Chrome Ball, 2.31" Dia.	1
2	3706000150	Plate, Ball Hitch Weldment	1
3	7115181050	Capscrew, 0.50"-13NC x 1.50"	4
4	7950180000	Lockwasher, 0.50" ID	4

* Also available as - 2503880023 with 1.88" Dia. Ball

* Also available as - 2503880024 with 2.00" Dia. Ball

* Also available as - 2503880025 with 2.31" Dia. Ball

UNDERLIFT TOOLS - BALL HITCH

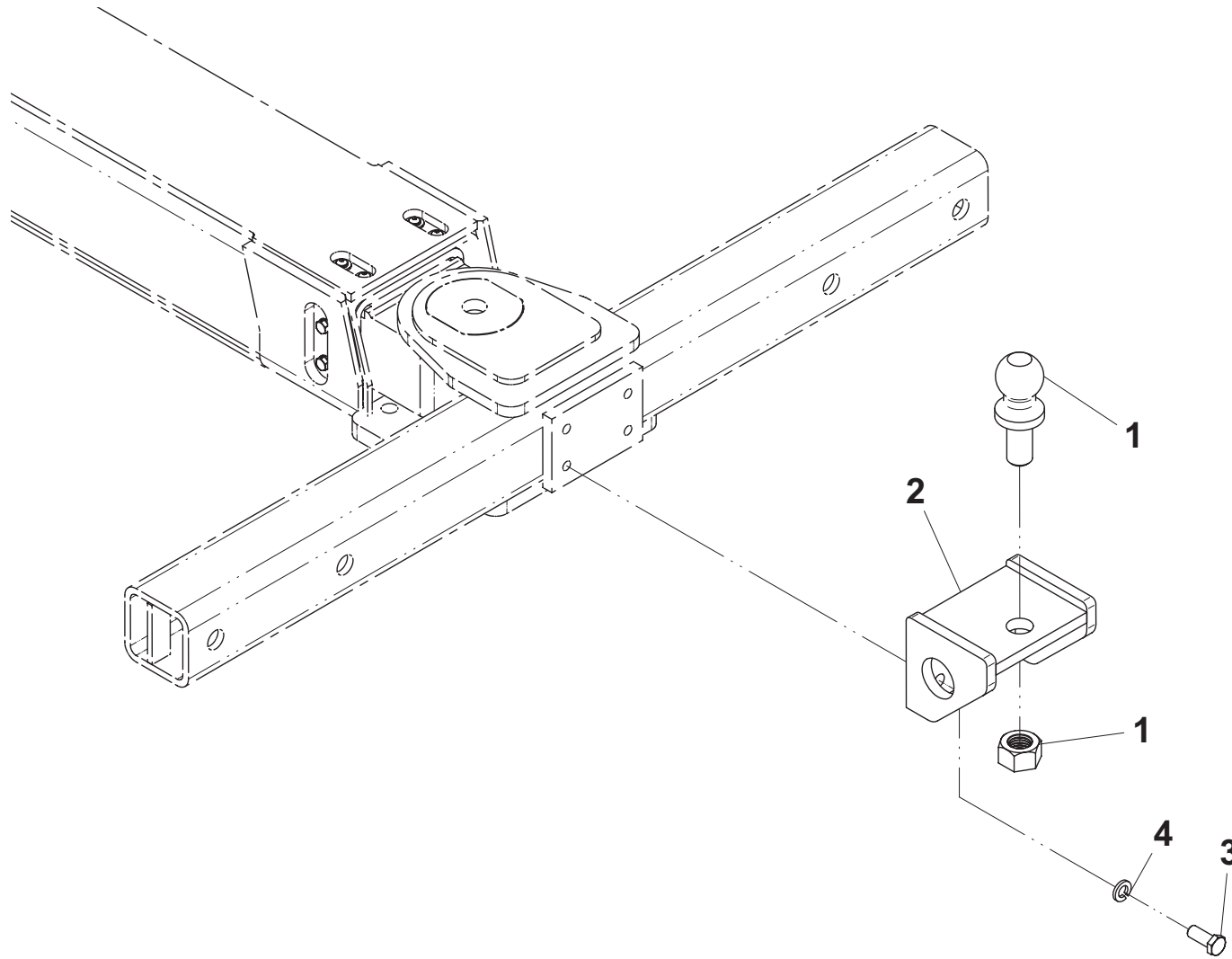

UNDERLIFT TOOLS - PINTLE HOOK

ITEM	PART NO.	DESCRIPTION	QTY
1	7561000020*	Hitch, Pintle Hook	1
2	7115181250*	Capscrew, 0.50"-13NC x 1.50"	4
3	7950180000*	Lockwasher, 0.50" ID	4
4	7056000007	Chrome Ball, 1.88" Dia.	1
	7056000008*	Chrome Ball, 2.00" Dia.	1
	7056000009	Chrome Ball, 2.31" Dia.	1

* Also available as Assembly 2504880026

UNDERLIFT TOOLS - PINTLE HOOK

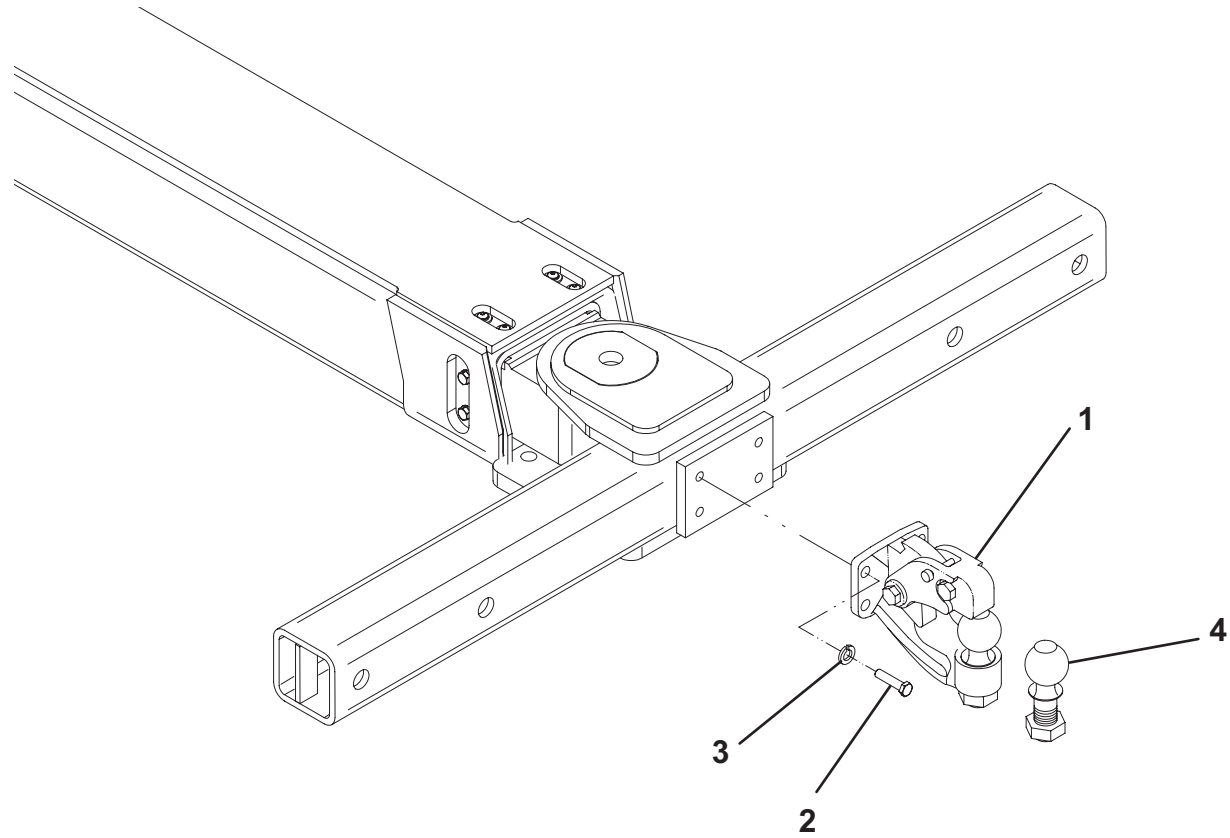

REAR TAIL PLATE INSTALLATION

ITEM	PART NO.	DESCRIPTION	QTY
1	4706003003	Plate - LH	1
2	4706003007	Plate - RH	1
3	7759000018	Rivet	14

REAR TAIL PLATE INSTALLATION

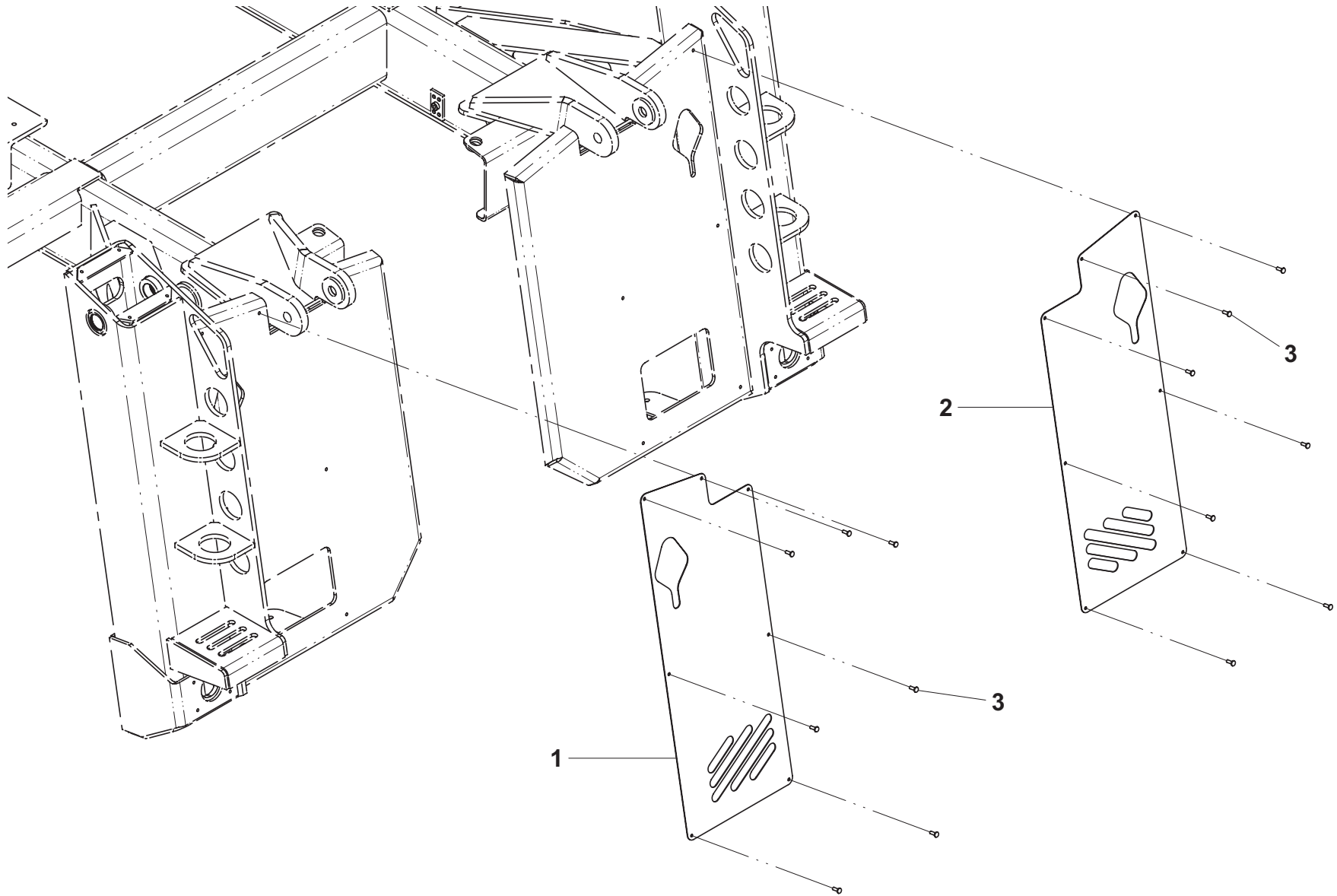

TRUCK BAR INSTALLATION

ITEM	PART NO.	DESCRIPTION	QTY
1	7002000355	Medium Duty Truck Bar	1
2	7262000014	Chain	2
3	7115225250	Capscrew, 0.75"-10NC x 6.50"	2
4	7660222601	Locknut, 0.75"-10NC	2
5	4017001049	Angle	2
6	7115161250	Capscrew, 0.38"-16NC x 1.50"	4
7	7950160162	Flatwasher, 0.38" ID	4
8	7679000010	Pad	2
9	7114140611	Capscrew, 0.25" - 20NC x 0.75"	4

TRUCK BAR INSTALLATION

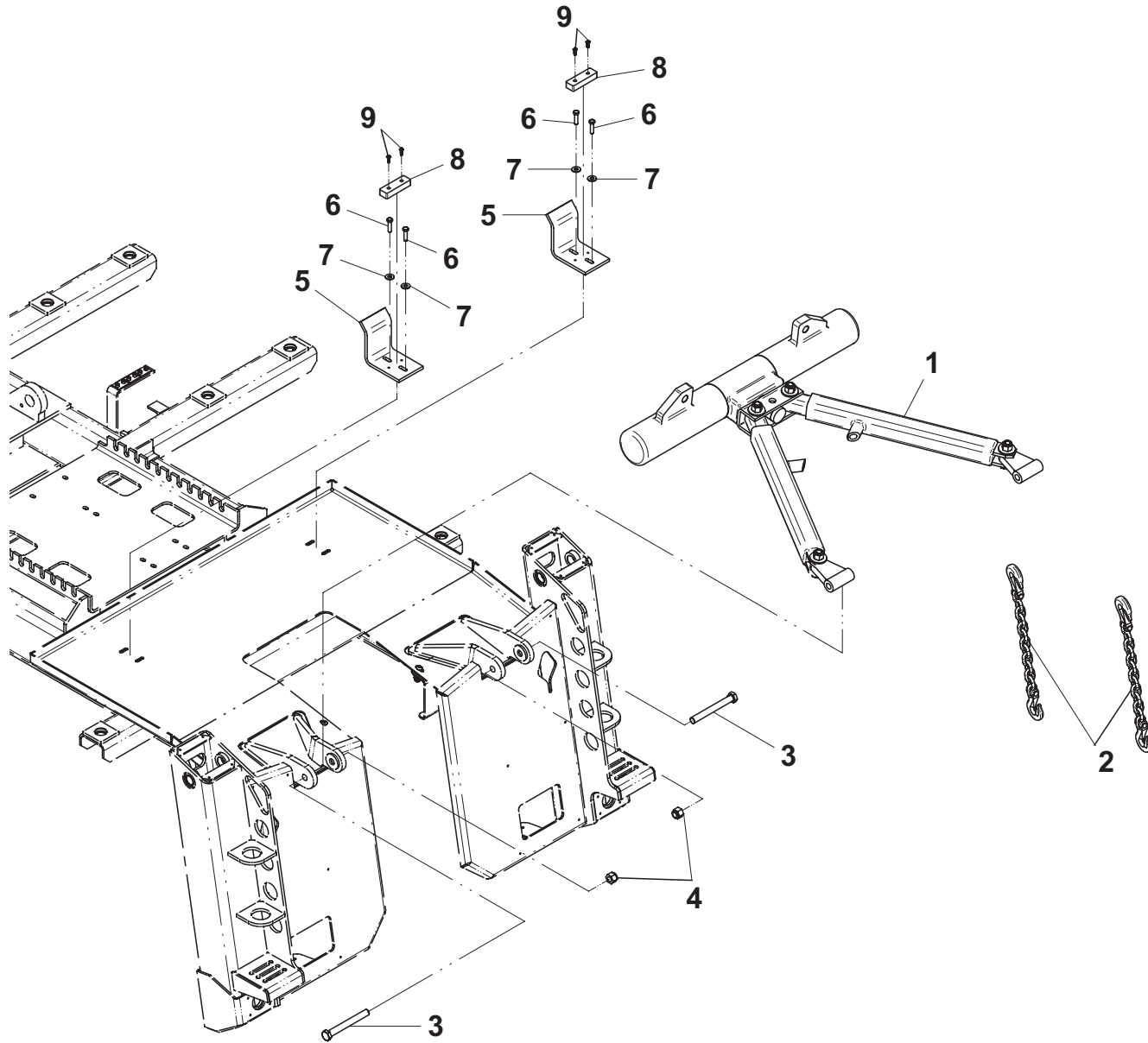

TRUCK BAR - 7002000355

ITEM	PART NO.	DESCRIPTION	QTY
1	70050219	Bar, Bottom	1
2	70050220	Bar, Spacer	2
3	70050221	Camlock	2
4	70050222	Grease Fitting	1
5	70050223	Locknut, 0.75"-10NC	4
6	70050224	Capscrew, 0.75"-10NC x 4.00"	2
7	70050225	Capscrew, 0.75"-10NC x 3.00"	2
8	70050226	Knuckle	2
9	70050227	Shackle	2

TRUCK BAR - 7002000355

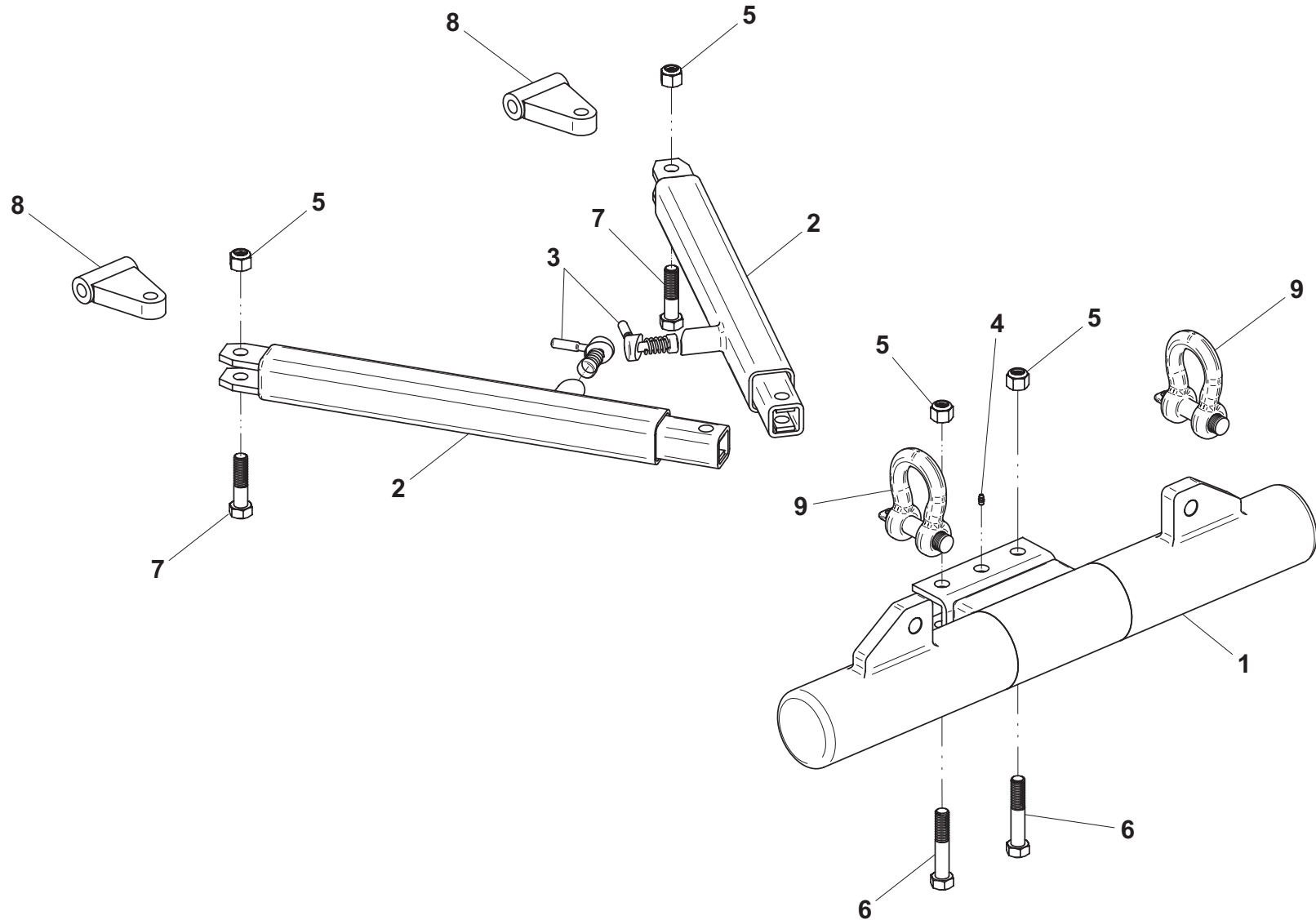

BODY CONFIGURATIONS

ITEM	PART NO.	DESCRIPTION	QTY	ITEM	PART NO.	DESCRIPTION	QTY
150" CA				120" CA			
1	3097000244	Body Assembly LH	1	1	3097000244	Body Assembly LH	1
	3097000245	Body Assembly RH	1		3097000245	Body Assembly RH	1
2	3504740021	Toolbox Assembly 60"	1	2	3504740021	Toolbox Assembly 60"	1
3	3504740019	Toolbox Assembly 30"	1				
138" CA				108" CA			
1	3097000244	Body Assembly LH	1	1	3097000244	Body Assembly LH	1
	3097000245	Body Assembly RH	1	2	3097000245	Body Assembly RH	1
2	3504740020	Toolbox Assembly 49"	1		3504740020	Toolbox Assembly 49"	1
3	3504740019	Toolbox Assembly 30"	1				

BODY CONFIGURATIONS

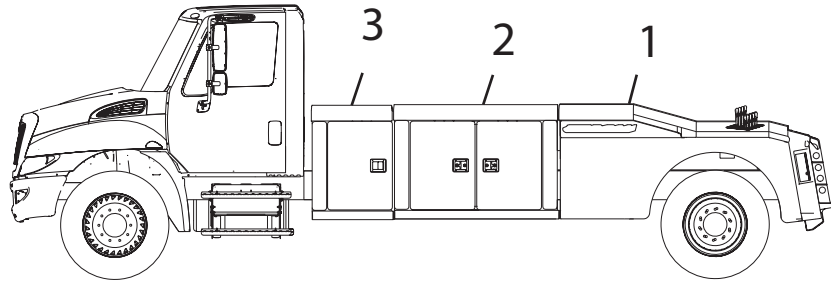

150" CA

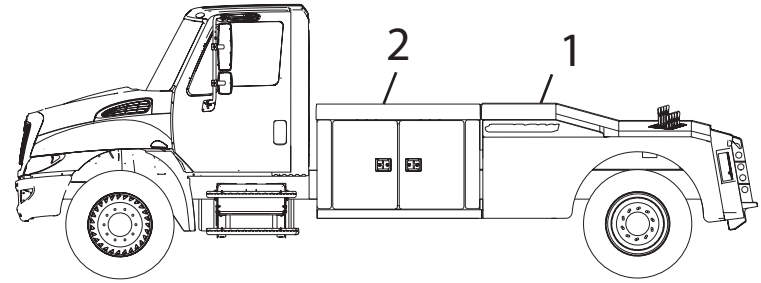

120" CA

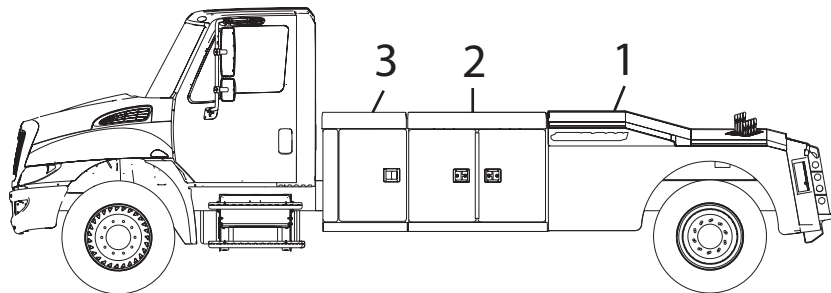

138" CA

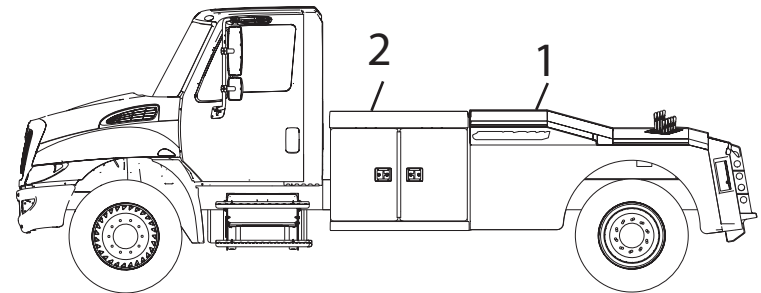

108" CA

BODY MOUNT ASSEMBLY

ITEM	PART NO.	DESCRIPTION	QTY	ITEM	PART NO.	DESCRIPTION	QTY
150" CA				120" CA			
1	7115202850	Capscrew, 0.63" - 11NC x 3.50"	18	1	7115202850	Capscrew, 0.63" - 11NC x 3.50"	14
2	7950200161	Flatwasher, 0.63" ID	18	2	7950200161	Flatwasher, 0.63" ID	14
3	7636000008	Rubber Mount	18	3	7636000008	Rubber Mount	14
4	7949000020	Washer	18	4	7949000020	Washer	14
5	7660200001	Nut, 0.63" - 11NC	18	5	7660200001	Nut, 0.63" - 11NC	14
6	7949000019	Washer	18	6	7949000019	Washer	14
7	3455000029	Frame Weldment, 30" & 49" Toolbox	1	7		NOT REQUIRED	
8	7115181650	Capscrew, 0.50" - 13NC x 2.00"	8	8	7115181650	Capscrew, 0.50" - 13NC x 2.00"	4
9	7950180252	Flatwasher, 0.50" ID	8	9	7950180252	Flatwasher, 0.50" ID	4
10	7660182301	Locknut, 0.50" - 13NC	8	10	7660182301	Locknut, 0.50" - 13NC	4
11	3274000014	Clamp Weldment	8	11	3274000014	Clamp Weldment	4
12	3455000030	Frame Weldment, 60" Toolbox	1	12	3455000030	Frame Weldment, 60" Toolbox	1
138" CA				108" CA			
1	7115202850	Capscrew, 0.63" - 11NC x 3.50"	18	1	7115202850	Capscrew, 0.63" - 11NC x 3.50"	14
2	7950200161	Flatwasher, 0.63" ID	18	2	7950200161	Flatwasher, 0.63" ID	14
3	7636000008	Rubber Mount	18	3	7636000008	Rubber Mount	14
4	7949000020	Washer	18	4	7949000020	Washer	14
5	7660200001	Nut, 0.63" - 11NC	18	5	7660200001	Nut, 0.63" - 11NC	14
6	7949000019	Washer	18	6	7949000019	Washer	14
7	3455000029	Frame Weldment, 30" & 49" Toolbox	2	7	3455000029	Frame Weldment, 30" & 49" Toolbox	1
8	7115181650	Capscrew, 0.50" - 13NC x 2.00"	8	8	7115181650	Capscrew, 0.50" - 13NC x 2.00"	4
9	7950180252	Flatwasher, 0.50" ID	8	9	7950180252	Flatwasher, 0.50" ID	4
10	7660182301	Locknut, 0.50" - 13NC	8	10	7660182301	Locknut, 0.50" - 13NC	4
11	3274000014	Clamp Weldment	8	11	3274000014	Clamp Weldment	4
12		NOT REQUIRED		12		NOT REQUIRED	

BODY MOUNT ASSEMBLY

BODY PANELS REMOVED FOR CLARITY
 150" CA BODY SHOWN

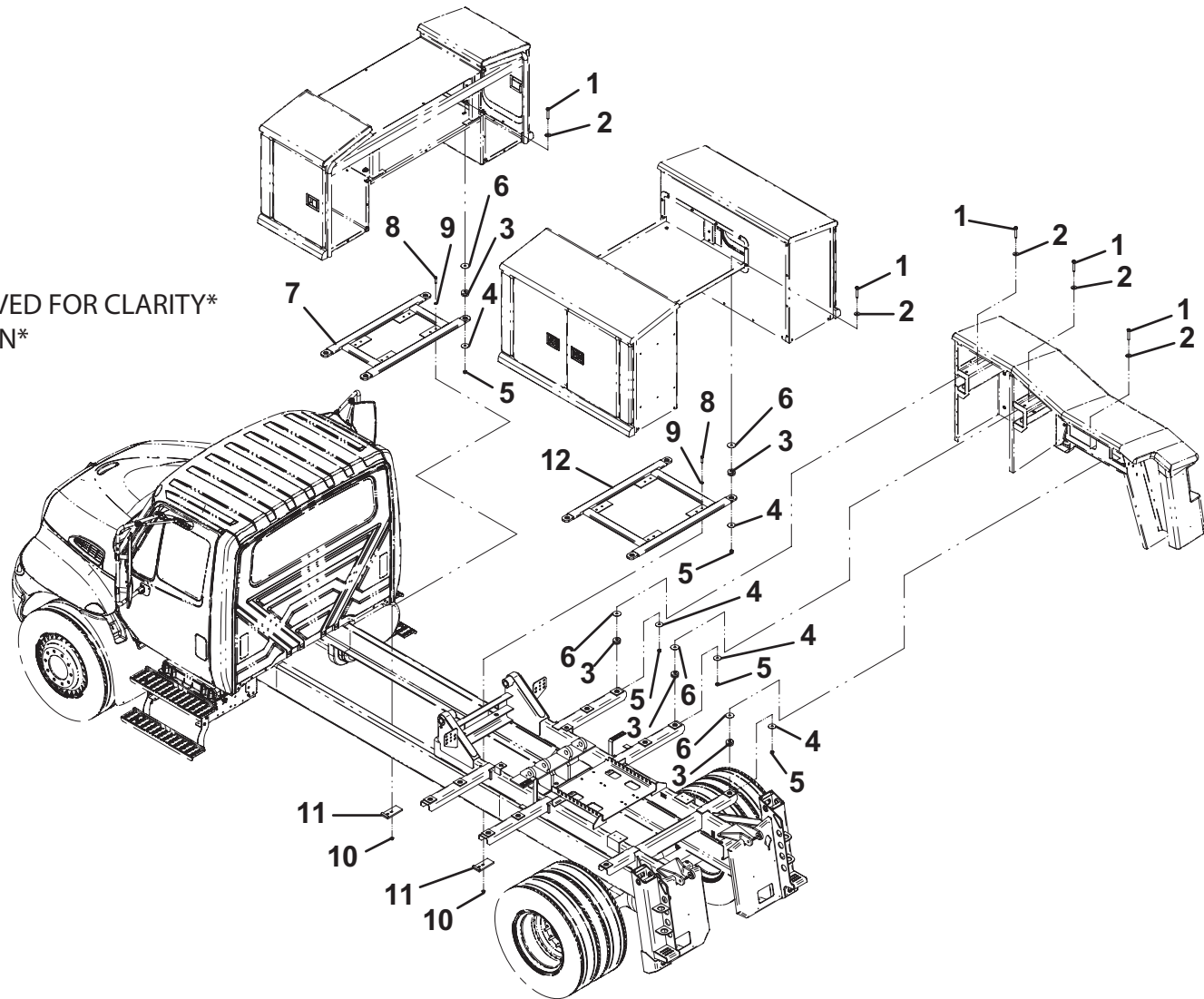

60" & 49" TOOLBOX ASSEMBLY

ITEM	PART NO.	DESCRIPTION	QTY
1	3504740005	Bondment, LH 60" Toolbox	1
	3504740009	Bondment, LH 49" Toolbox	
2	3504740006	Bondment, RH 60" Toolbox	1
	3504740010	Bondment, RH 49" Toolbox	
3	3504740007	Bondment, Tunnel 60" Toolbox	1
	3504740008	Bondment, Tunnel 49" Toolbox	
4	7115140850	Capscrew, 0.25" - 20NC x 1.00"	24
5	7950140161	Flatwasher, 0.25" ID	48
6	7660142601	Locknut, 0.25" - 20NC	24

60" & 49" TOOLBOX ASSEMBLY

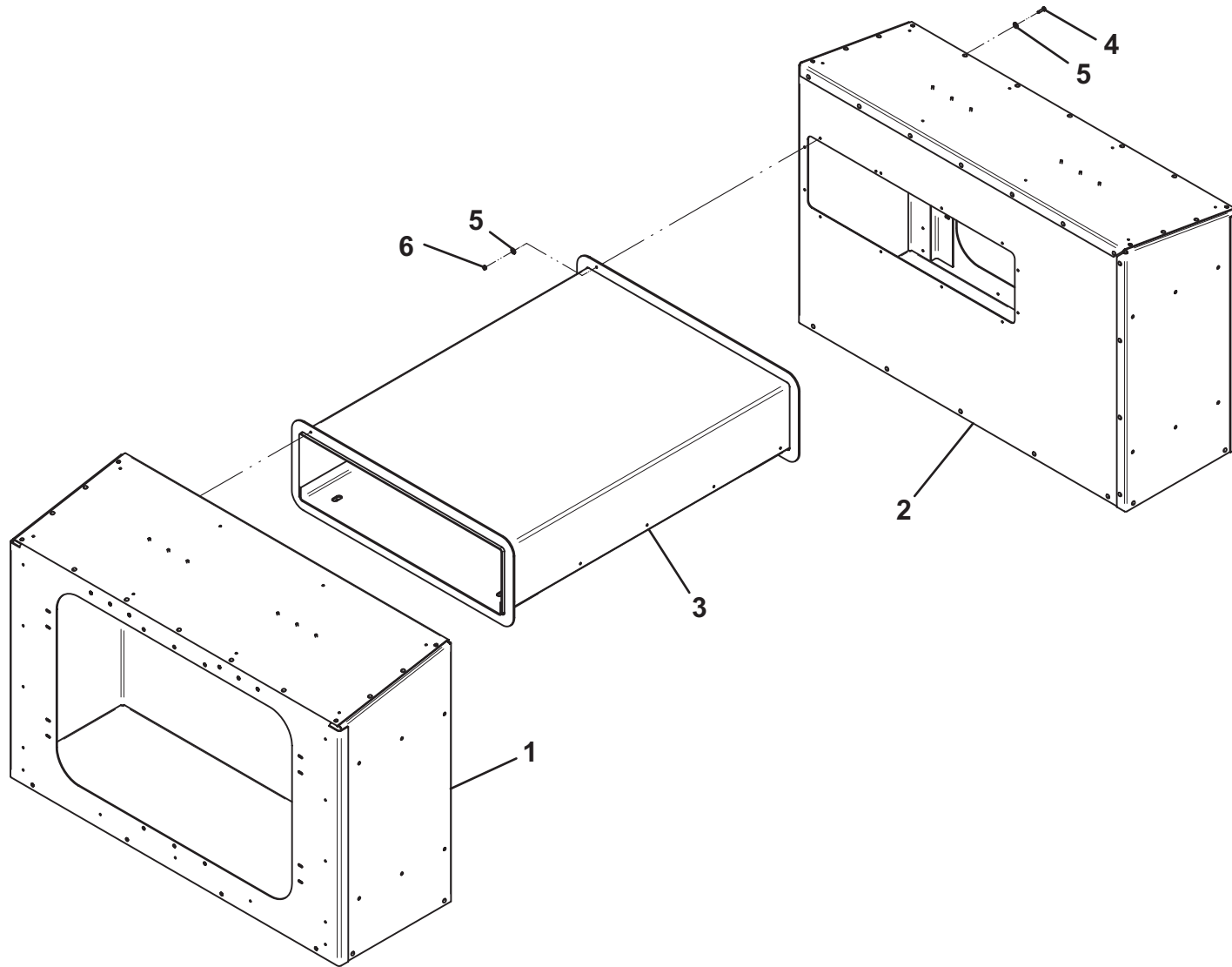

60" & 49" TOOLBOX DOOR ASSEMBLY

ITEM	PART NO.	DESCRIPTION	QTY	ITEM	PART NO.	DESCRIPTION	QTY
1	4686000166	Door	1	34	4686000167	Door	1
2	4632000019	Seal	2	35	7114100318	Capscrew, #10 - 24NC x 0.28"	8
3	4811000332	Sheet	2	36	4686000187	Door	1
4	7555000002	Hinge	8	37	4686000188	Door	1
5	4812000052	Shim	8	38	4062000173	Bar	8
6	7585000011	T-Handle Latch	4	39	7949000025	Lockwasher, 11MM x 6.4MM	28
7	7114100418	Capscrew, #10 - 24NC x 0.50"	28	40	7950100163	Flatwasher, #10 ID	16
8	4585000015	Latch Roller	8	41	7114140818	Capscrew, 0.25" - 20NC x 1.00"	12
9	4178000334	Bracket	8	42	1001139872	Rubber Pad	1
10	7796000031	Gasket	4		1001139872*	Rubber Pad	
11	7660152604	Locknut, 0.31" - 18NC	12				
12	7843000020	Gas Shock	4				
13	7178000023	Ball Stud Bracket	4				
14	7865000001	Ball Stud`	4				
15	4178000240	Bracket	4				
16	4811000335	Sheet	4				
17	4632000020	Seal	2				
18	7114141018	Capscrew, 0.25" - 20NC x 1.25"	28				
19	7660142604	Locknut, 0.25" - 20NC	28				
20	7950140163	Flatwasher, 0.25" ID	56				
21	4679000183	Pad	1				
	4679000181*	Pad					
22	4679000184	Pad	1				
	4679000182*	Pad					
23	7114100618	Capscrew, #10 - 24NC x 0.75"	16				
24	7660102604	Locknut, #10 - 24NC	16				
25	7114140418	Capscrew, 0.25" - 20NC x 0.50"	24				
26	7950140503	Lockwasher, 0.25" ID	24				
27	7831000040	Spacer	8				
28	7114150650	Capscrew, 0.31" - 18NC x 0.75"	8				
29	4062000368	Bar	4				
30	4811000336	Sheet	8				
31	4811000337	Sheet	8				
32	7690000810	Cotter Pin	8				
33	7189000015	Rubber Bumper	6				

* Used on 49" Toolbox assembly

60" & 49" TOOLBOX DOOR ASSEMBLY

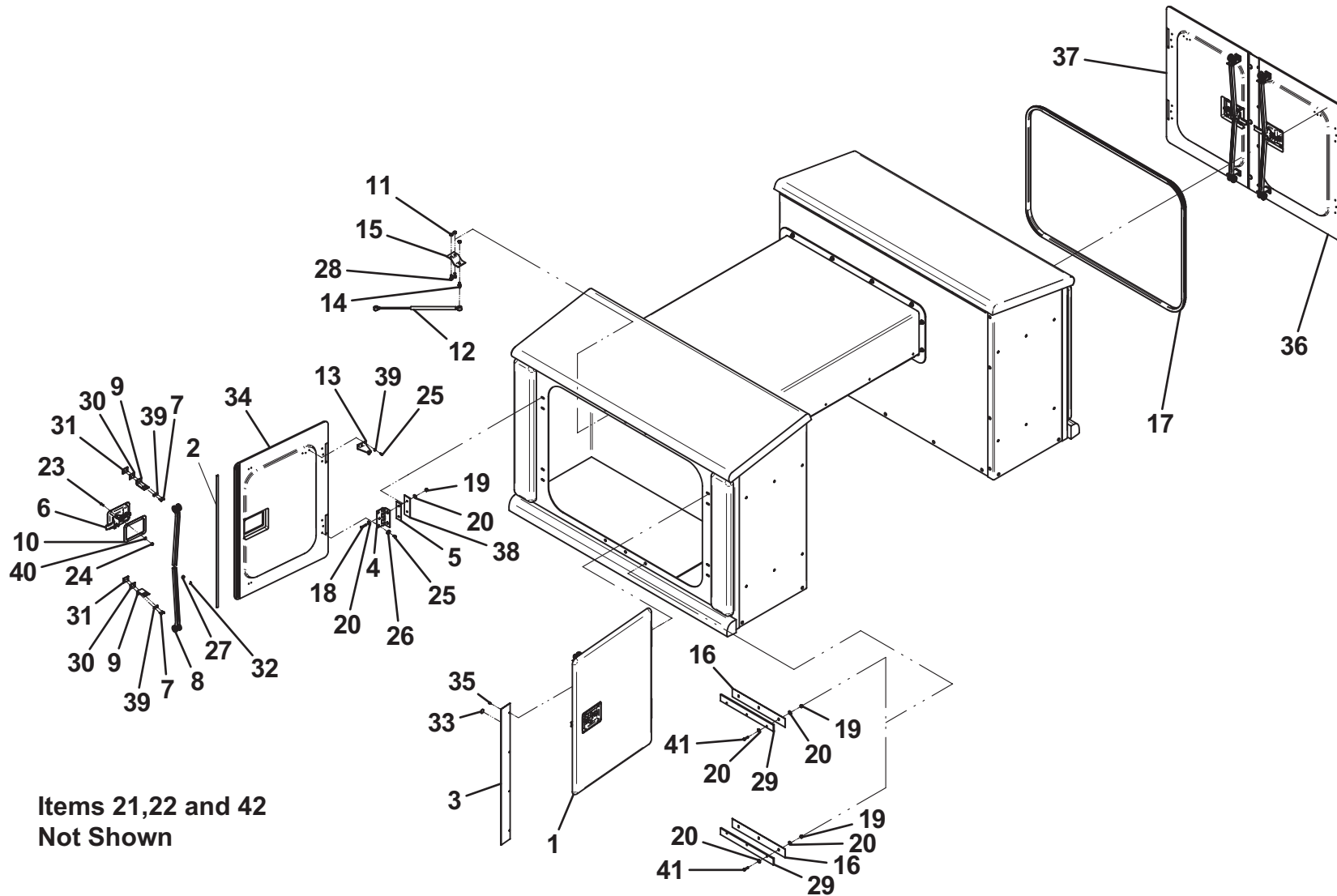

Items 21, 22 and 42
Not Shown

60" & 49" TOOLBOX BODY PANEL INSTALLATION

ITEM	PART NO.	DESCRIPTION	QTY
1	3504740004	Toolbox, 60" Assembly	1
	3504740011*	Toolbox, 49" Assembly	
2	7686000051	Panel, Roof Cap 60" Toolbox	2
	7686000050*	Panel, Roof Cap 49" Toolbox	
3	7686000055	Panel, Flare Strip 60" Toolbox	2
	7686000054*	Panel, Flare Strip 49" Toolbox	
4	7686000052	Panel, Filler Strip	4
5	4679000120	Pad	16
6	7790141651	Screw, 0.25" x 1.00"	50

60" & 49" TOOLBOX BODY PANEL INSTALLATION

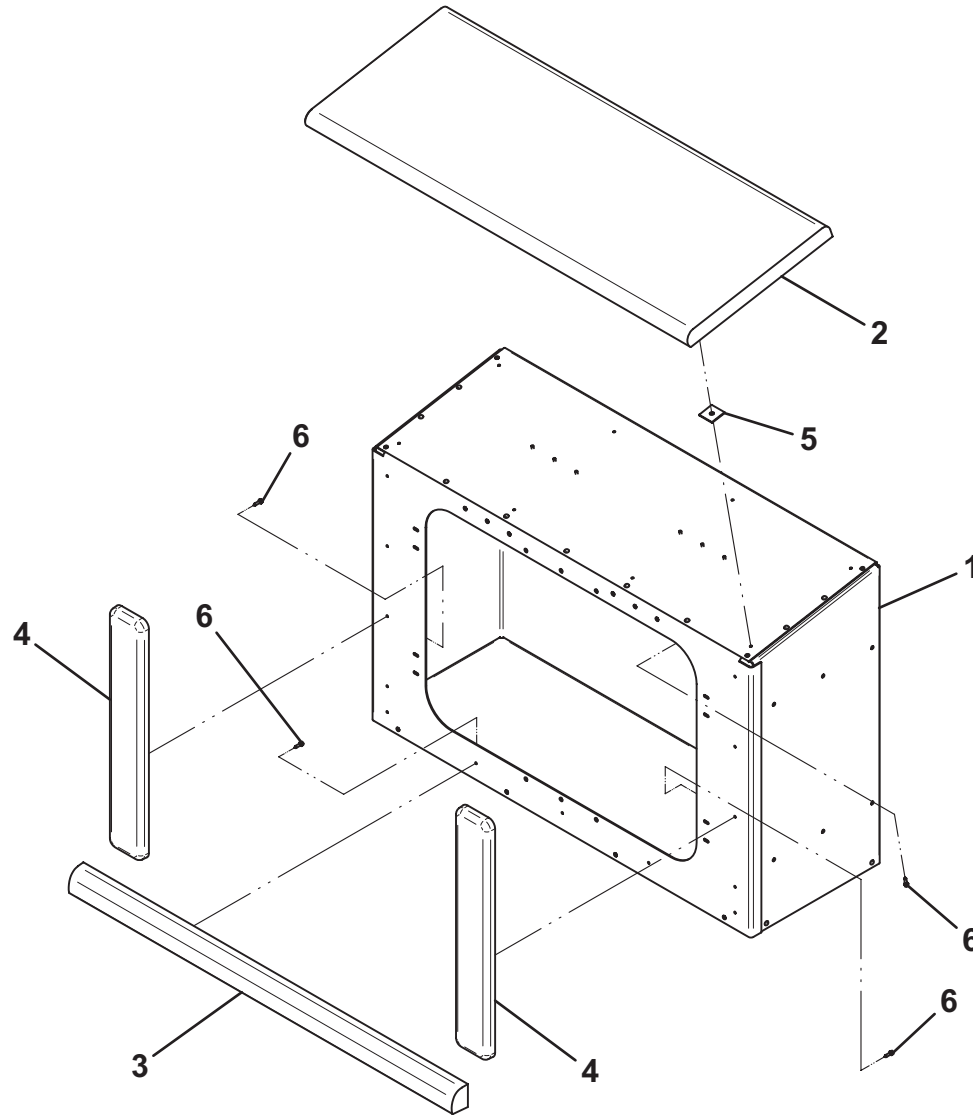

30" TOOLBOX BODY DOOR ASSEMBLY

ITEM	PART NO.	DESCRIPTION	QTY
1	4686000085	Panel	1
2	7950160163	Flatwasher, 0.38" ID	2
3	4811000135	Door Guard	2
4	7555000002	Hinge	4
5	4812000052	Shim	4
6	7595000005	Latch	2
7	7114100418	Capscrew, #10 - 24NC x 0.50"	6
8	7585000009	Latch Striker	2
9	4178000347	Bracket	2
10	7796000038	Gasket	2
11	7660152604	Locknut, 0.31" - 18NC	6
12	7843000020	Gas Shock	2
13	7178000023	Bracket	2
14	7865000001	Ball Stud	2
15	4178000250	Bracket	2
16	7114140650	Capscrew, 0.25" - 20NC x 1.00"	4
17	4632000012	Door Seal	2
18	7114141018	Capscrew, 0.25" - 20NC x 1.25"	8
19	7660142604	Locknut, 0.25" - 20NC	8
20	7950140163	Flatwasher, 0.25" ID	20
21	4679000179	Rubber Pad	2
22	4679000180	Rubber Pad	1
23	7114100618	Capscrew, #10 - 24NC x 1.00"	8
24	7660102604	Locknut, #10 - 24NC	8
25	7114140418	Capscrew, #10 - 24NC x 0.75"	12
26	7950140503	Lockwasher, 0.25" ID	12
27	7661000021	Locknut, 0.38" - 16NC	2
28	7413000002	Nutsert, 0.25" - 20NC	4
29	7114150650	Capscrew, 0.31" - 18NC x 0.75"	4
30	4686000086	Panel	1
31	4062000173	Bar	4
32	7949000025	Lockwasher, 11mm x 6.4mm	6
33	7950100163	Flatwasher, #10 ID	8
34	7950140003	Lockwasher, 0.25" ID	4

30" TOOLBOX BODY DOOR ASSEMBLY

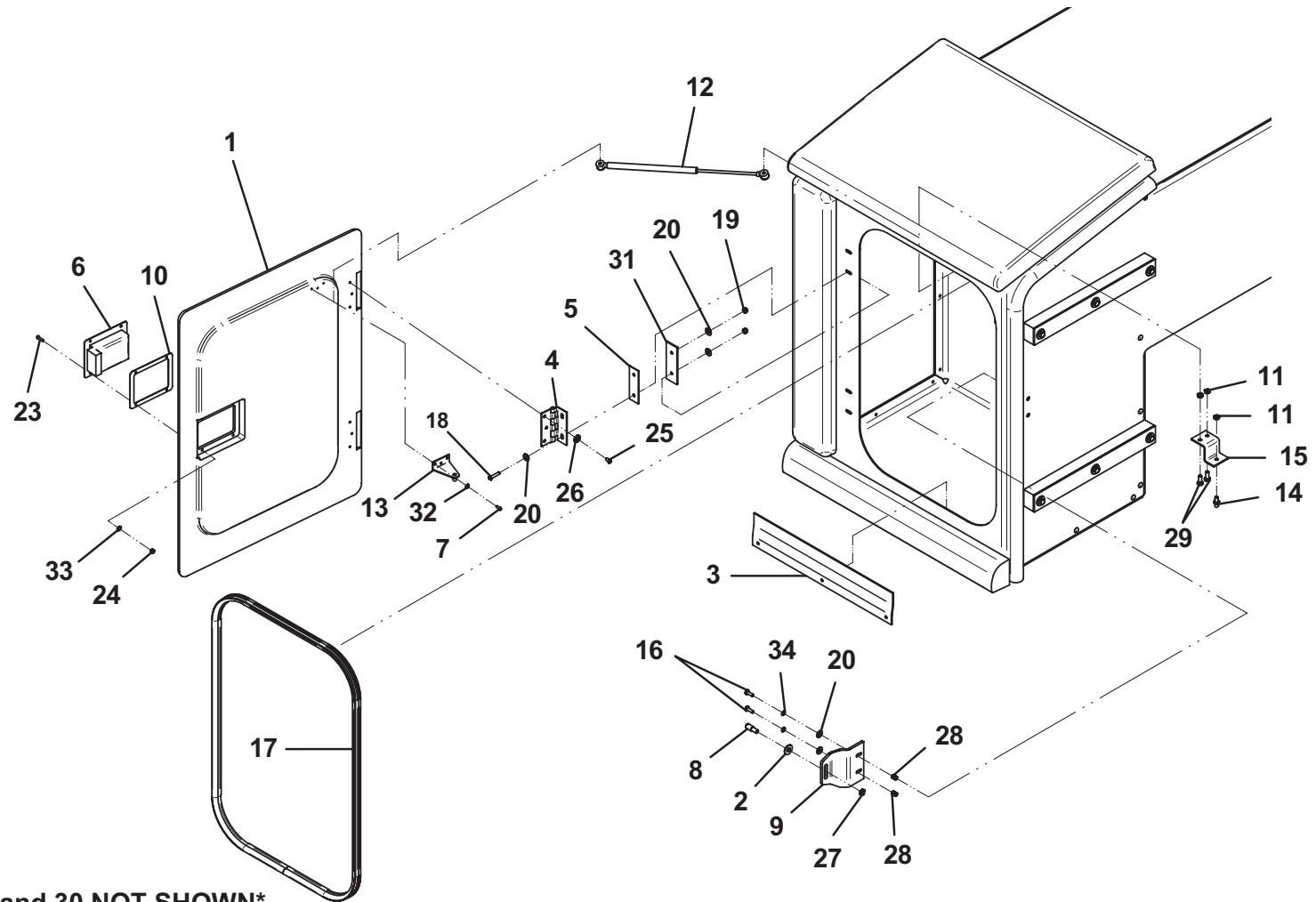

30" TOOLBOX BODY PANEL INSTALLATION

ITEM	PART NO.	DESCRIPTION	QTY
1	3504740003	Toolbox Assembly 30"	1
2	7686000049	Panel, Toolbox Cap	2
3	7686000053	Panel, Flare Strip	2
4	7686000052	Panel, Filler Strip	2
5	4679000120	Rubber Pad	8
6	7790141651	Screw, 0.25" x 1.00"	22

30" TOOLBOX BODY PANEL INSTALLATION

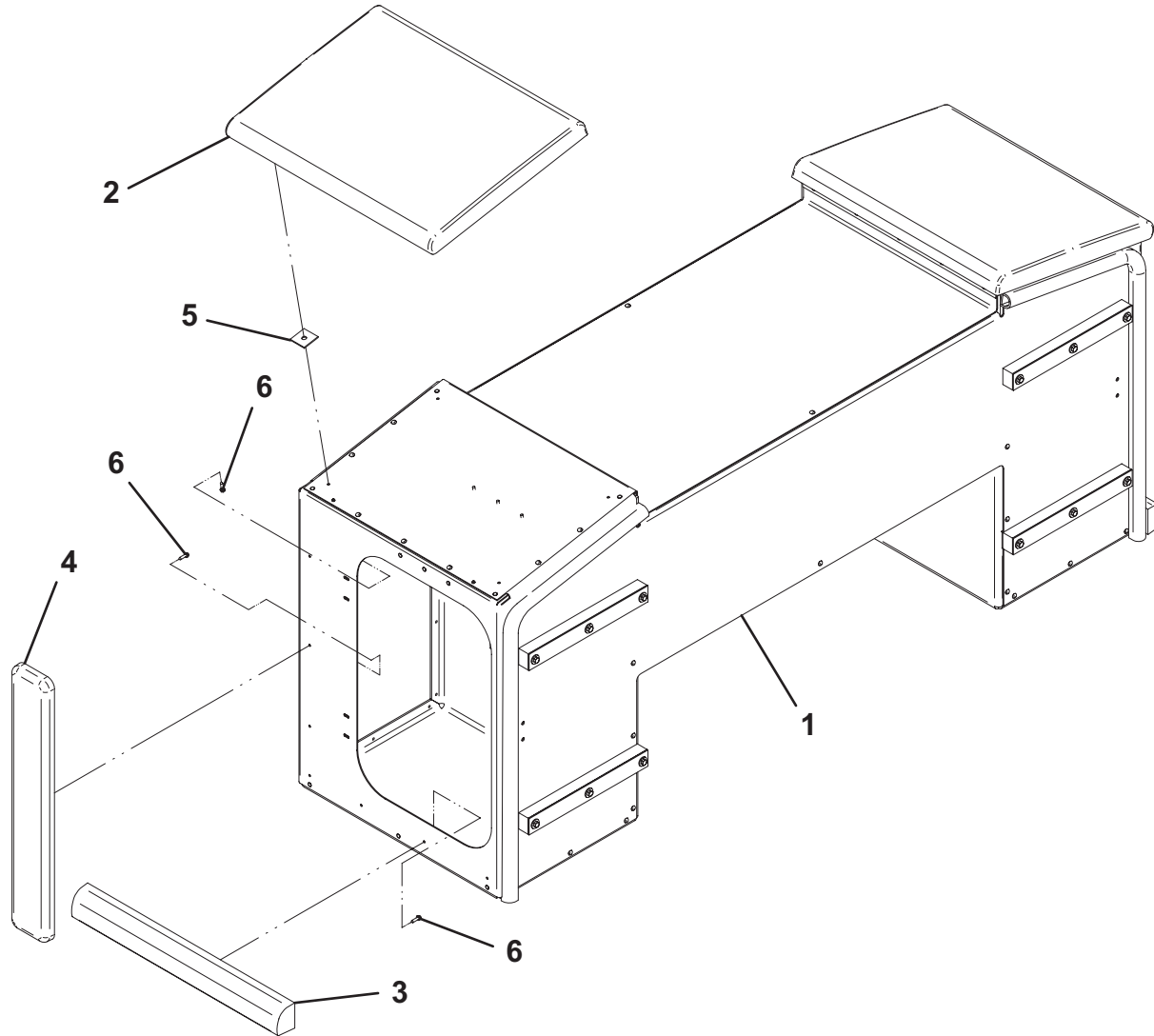

BODY PANEL ASSEMBLY - 108" CA BASE

ITEM	PART NO.	DESCRIPTION	QTY
1	3504080001	Body Bonding Assembly - LH	1
	3504080002	Body Bonding Assembly - RH	
2	7686000099	Roof Cap Panel - LH	1
	7686000100	Roof Cap Panel - RH	
3	7686000047	Side Body Panel - LH	1
	7686000048	Side Body Panel - RH	
4	7686000045	Tail Light Panel - LH	1
	7686000046	Tail Light Panel - RH	
5	7686000016	Logo Panel - LH	1
	7686000015	Logo Panel - RH	
6	7189000015	Bumper, 0.81" Dia x 0.13" Thk	5
7	4679000120	Pad, Rubber - 0.12" Thk	15
8	7790141251	Screw, Self Tapping 0.25" x 1.25"	18
9	7949000022	Washer, Fender 1.00" OD x 0.25" ID	27
10	4636000031	Rubber Mount, 1.06" x 0.36"	24
11	7790142051	Screw, Self Tapping 0.25" x 1.25"	30
12	4679000122	Pad, Rubber 0.38" Thk	4
13	4636000033	Rubber Mount, 2.00" x 1.00"	3
14	4691000245	Pin, 0.63" Dia x 1.88"	3
15	7950160161	Flatwasher, 0.38" ID	3
16	7660160001	Nut, 0.38"-16 NC	3
17	7950160000	Lockwasher, 0.38" ID	3

Hardware Quantities Are Per Side.

BODY PANEL ASSEMBLY - 108" CA BASE

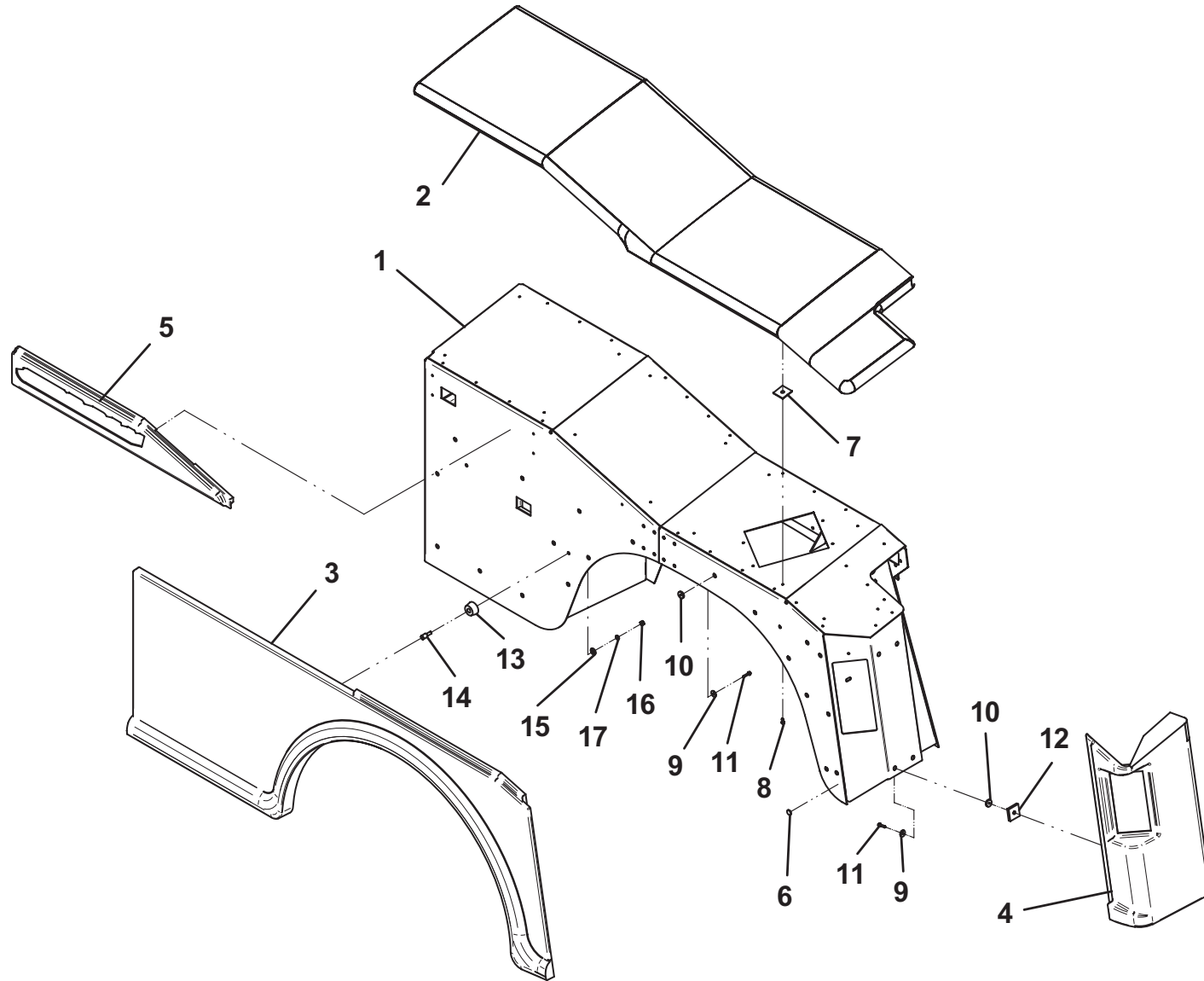

30", 49" & 60" TOOLBOX SPACER AND BRACKET ASSEMBLY

ITEM	PART NO.	DESCRIPTION	QTY
1	4178000270	Bracket	3
2	7115181050	Capscrew, 0.50" - 13NC x 1.25"	12
3	7950180153	Flatwasher, 0.50" ID	12
4	7660182301	Locknut, 0.50" - 13NC	12
5	4679000136	Pad	4
6	8632000011	Rubber Molding	9
7	7115162250	Capscrew, 0.38" - 16NC x 2.75"	12
8	7950160161	Flatwasher, 0.38" ID	24
9	7660160001	Nut, 0.38" - 16NC	12
10	4062000243	Bar	8

30", 49" & 60" TOOLBOX SPACER AND BRACKET ASSEMBLY

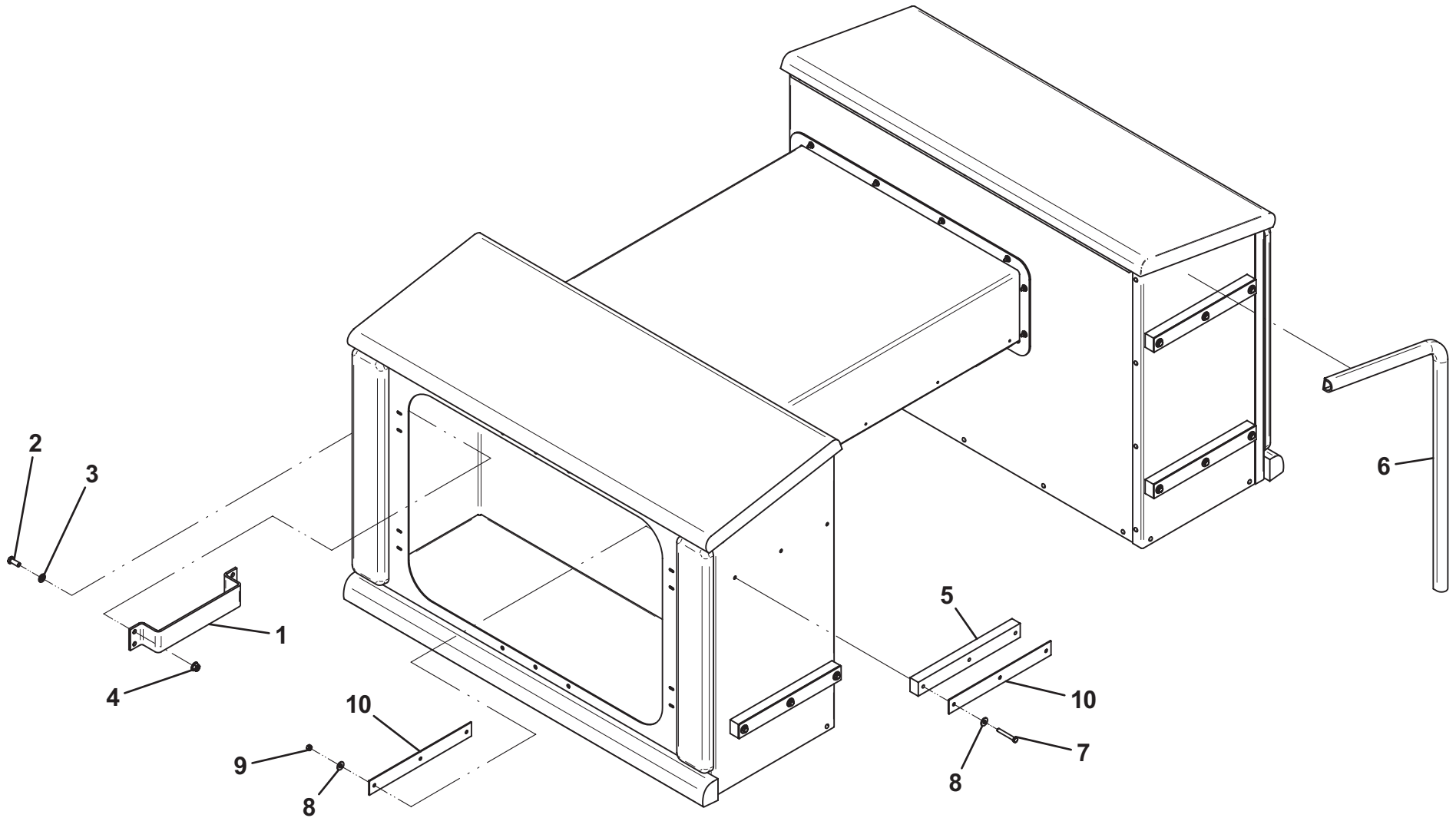

TOOL HOLDER INSTALLATION 49" & 60" TOOLBOX

ITEM	PART NO.	DESCRIPTION	QTY
1	3178000287	Bracket	1
2	3178000221	Bracket	2
3	7115161250	Capscrew, 0.38" - 16NC x 1.50"	12
4	7660162601	Locknut, 0.38" - 16NC	12
5	7950160141	Flatwasher, 0.38" ID	24
6	4062000381	Bar	2

TOOL HOLDER INSTALLATION 49" & 60" TOOLBOX

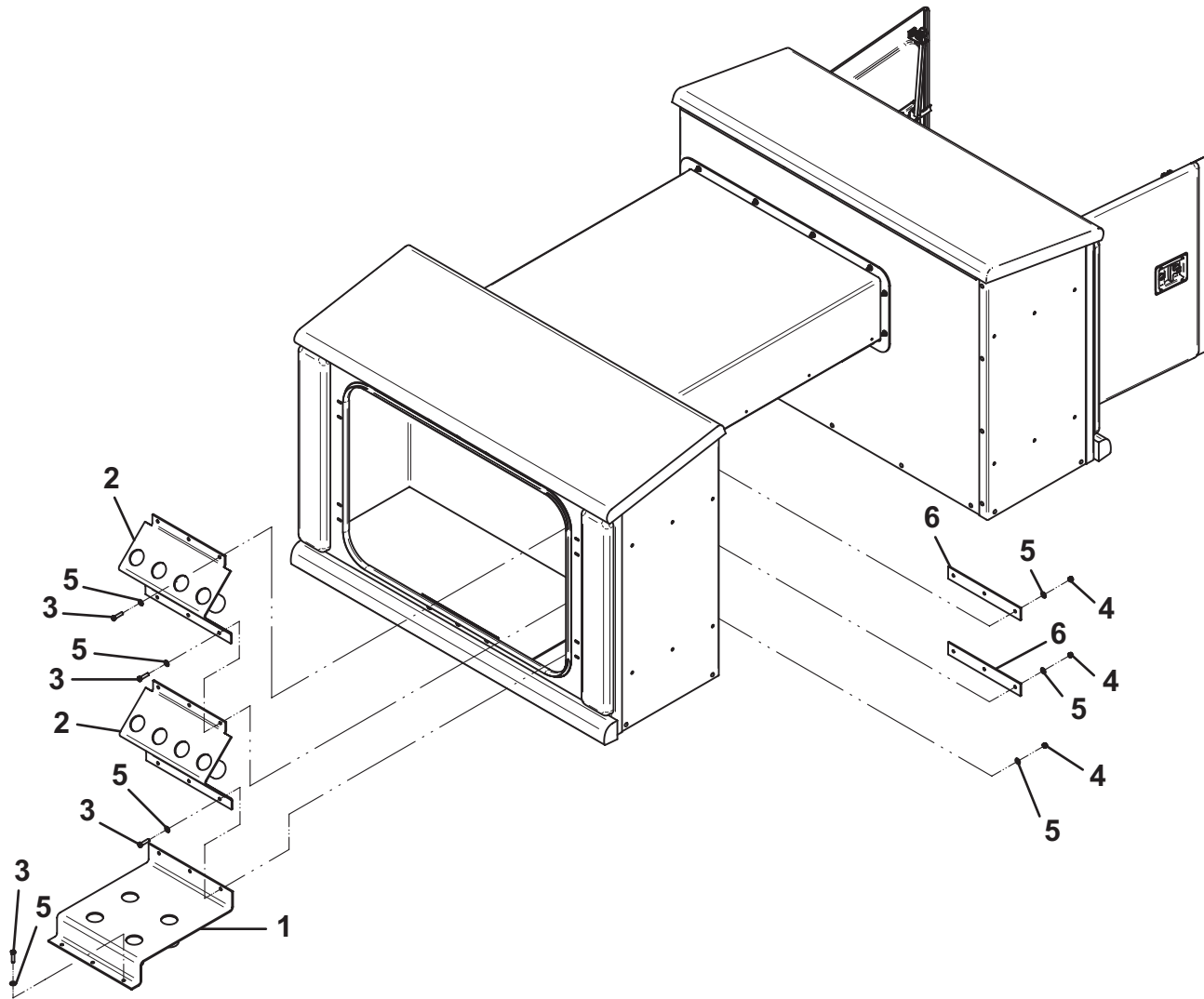

MUDFLAP INSTALLATION

ITEM	PART NO.	DESCRIPTION	QTY
1	4178000242	Bracket	2
2	4017000719	Angle	2
3	4706001815	Plate	2
4	7638000007	Mudflap	2
5	7118151250	Capscrew, 0.31" - 18NC x 1.50"	12
6	7950150161	Flatwasher, 0.31" ID	40
7	7660152601	Locknut, 0.31" - 18NC	20
8	7115150850	Capscrew, 0.31" - 18NC x 1.00"	8

MUDFLAP INSTALLATION

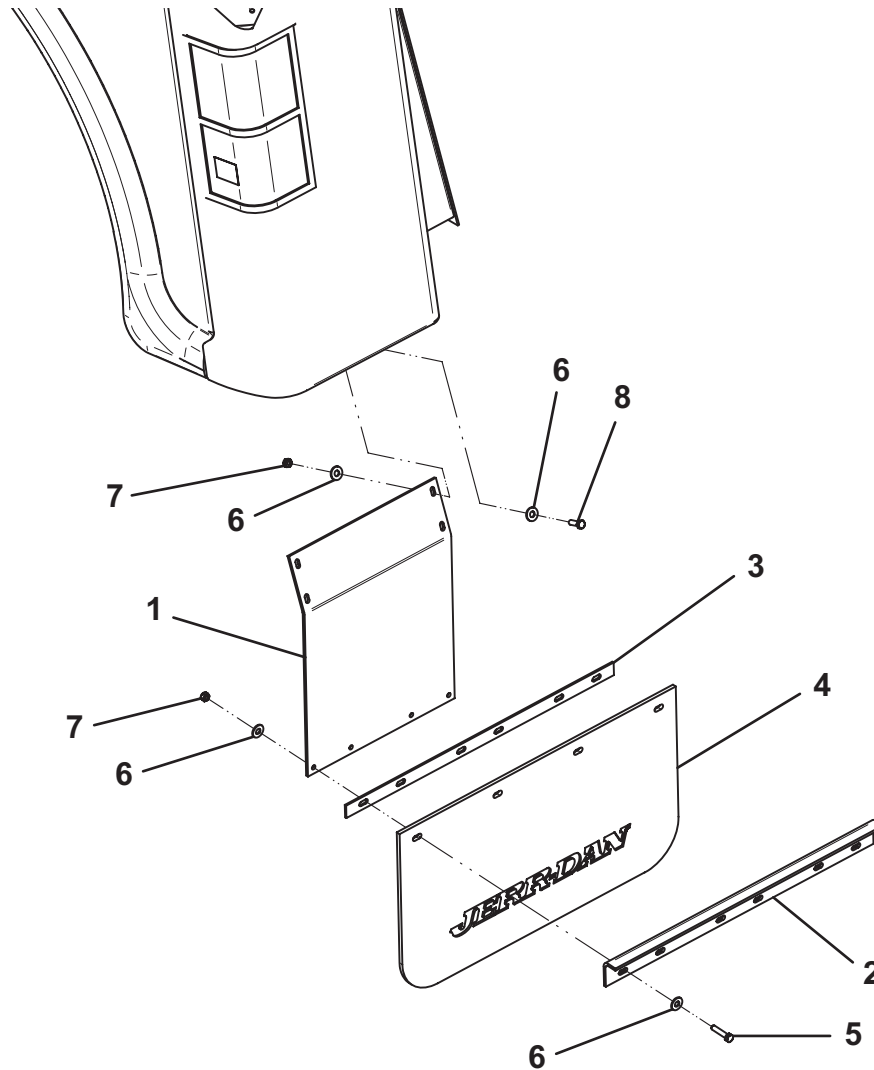

BACK-UP ALARM INSTALLATION - 97DB FIXED & 82-102DB VARIABLE

ITEM	PART NO.	DESCRIPTION	QTY
1	7011000007	Alarm, 97Db Fixed	1
	7011000012	Alarm, 82-102Db Variable	1
2	7111141050	Capscrew, 0.25" - 20NC x 1.25"	2
3	7660142600	Locknut, 0.25" - 20NC	2
4	7950140141	Flatwasher, 0.25" ID	4

BACK-UP ALARM INSTALL - 97DB FIXED & 82-102DB VARIABLE

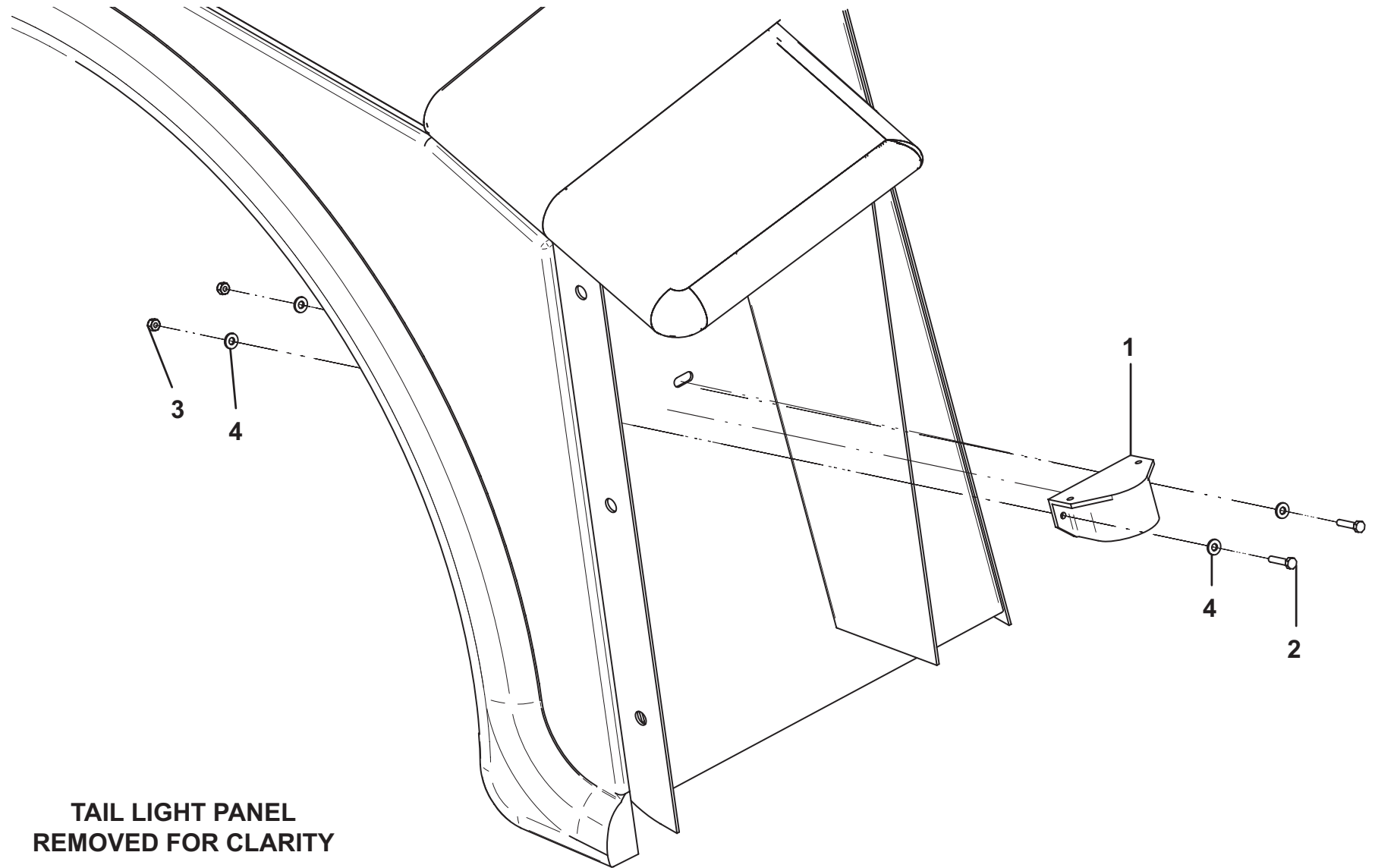

BATTERY BOX INSTALLATION

ITEM	PART NO.	DESCRIPTION	QTY
1	3314000048	Coverplate, Battery Box - LH	1
	3314000049	Coverplate, Battery Box - RH	
2	7120000070	Thumbscrew, 0.25"-20NC x 1.00"	4
3	7413000002	Nutsert, 0.25"-20NC	4

BATTERY BOX INSTALLATION

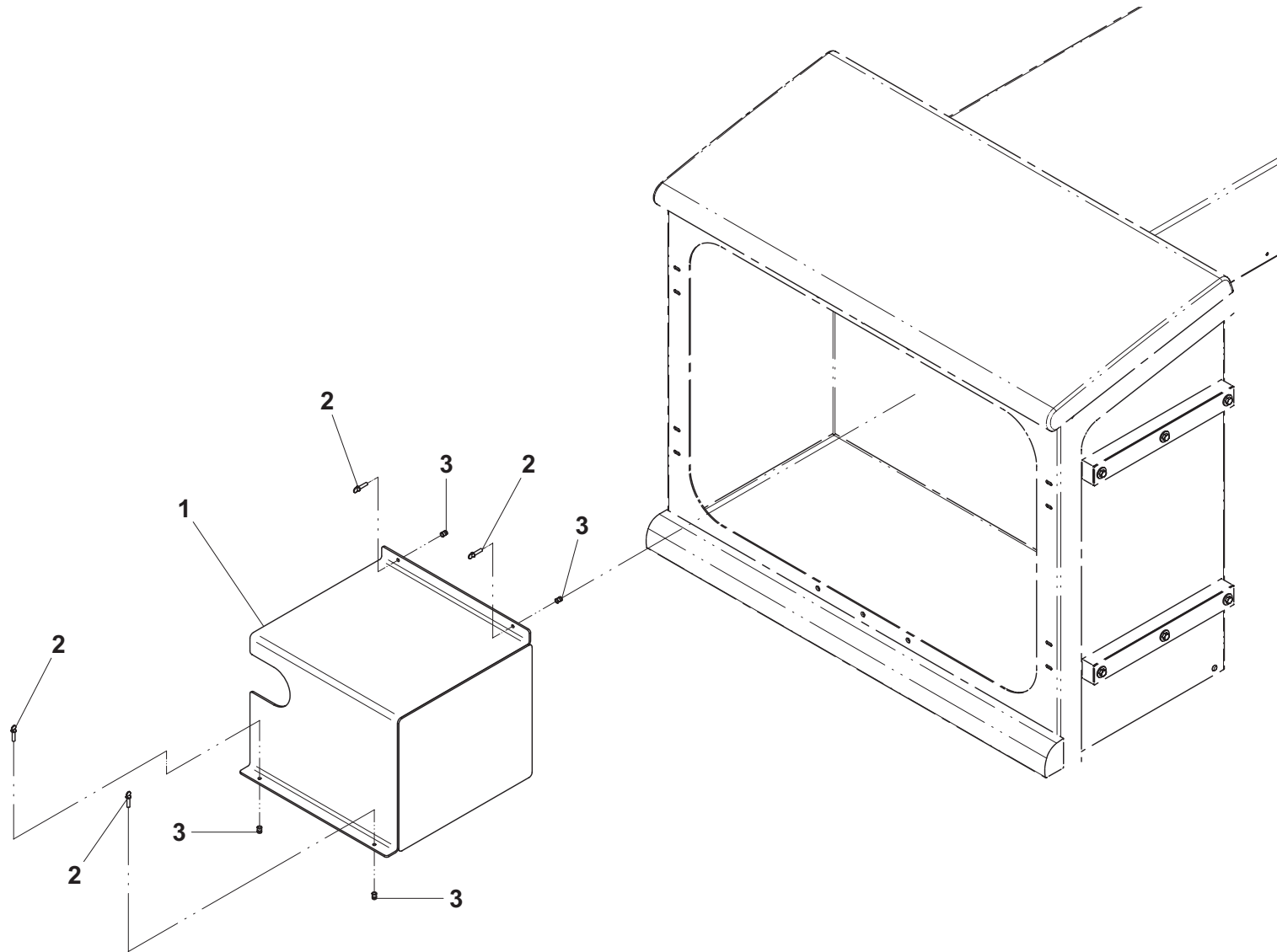

WHEEL DOLLY AND BRACKET INSTALLATION

ITEM	PART NO.	DESCRIPTION	QTY
1	3178000286	Bracket, Dolly Assembly	1
2	7115161050	Capscrew, 0.38" - 16NC x 1.25"	4
3	7950160161	Flatwasher, 0.38" ID	8
4	7660162601	Locknut, 0.38" - 16NC	4
5	4706002972	Plate	1
6	4178000340	Bracket	2
7	7115150864	Bolt, 0.31" - 18NC x 1.00"	6
8	7660152601	Locknut, 0.31" - 18NC	6
9	7950150161	Flatwasher, 0.31" ID	6
10	7002000022	Dollies, Self-Loading	1

WHEEL DOLLY AND BRACKET INSTALLATION

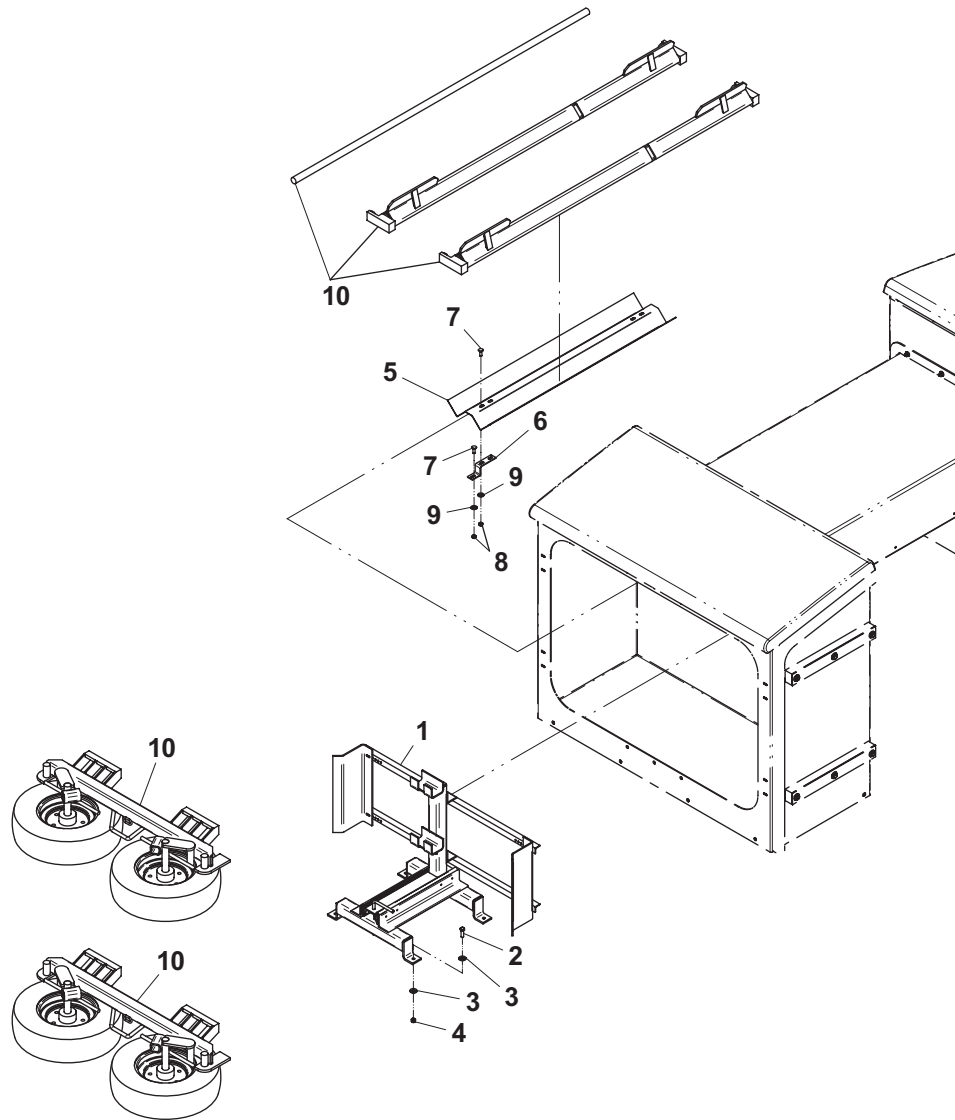

LIGHT PYLON INSTALLATION - 49/60" TOOLBOX

ITEM	PART NO.	DESCRIPTION	QTY
1	3241000116	Light Pylon, 38"	1
	3241000125	Light Pylon, 43"	1
	3241000219	Light Pylon, 51"	1
2	3177000047	Support Weldment	2
3	7114181250	Capscrew, 0.50" - 13NC x 1.50"	12
4	7660182601	Locknut, 0.50" - 13NC	12
5	4706002947	Plate	2
6	7796000060	Gasket	2
7	7493000008	Grommet	1

LIGHT PYLON INSTALLATION - 49/60" TOOLBOX

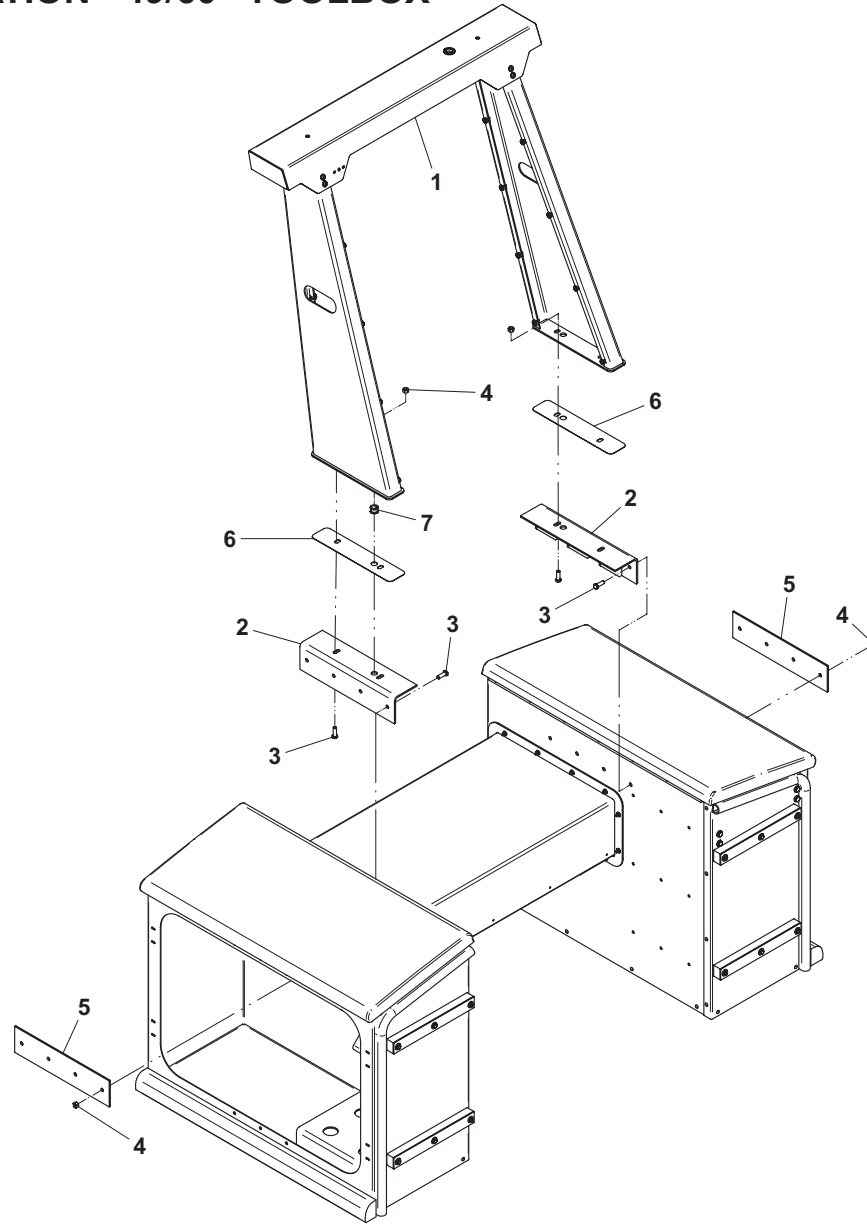

LIGHT PYLON INSTALLATION - 30" TOOLBOX

ITEM	PART NO.	DESCRIPTION	QTY
1	3241000116	Light Pylon, 38"	1
	3241000125	Light Pylon, 43"	1
	3241000219	Light Pylon, 51"	1
2	7493000008	Grommet	1
3	7114181250	Capscrew, 0.50" - 13NC x 1.50"	4
4	7660182601	Locknut, 0.50" - 13NC	4
5	67796000060	Gasket	1

LIGHT PYLON INSTALLATION - 30" TOOLBOX

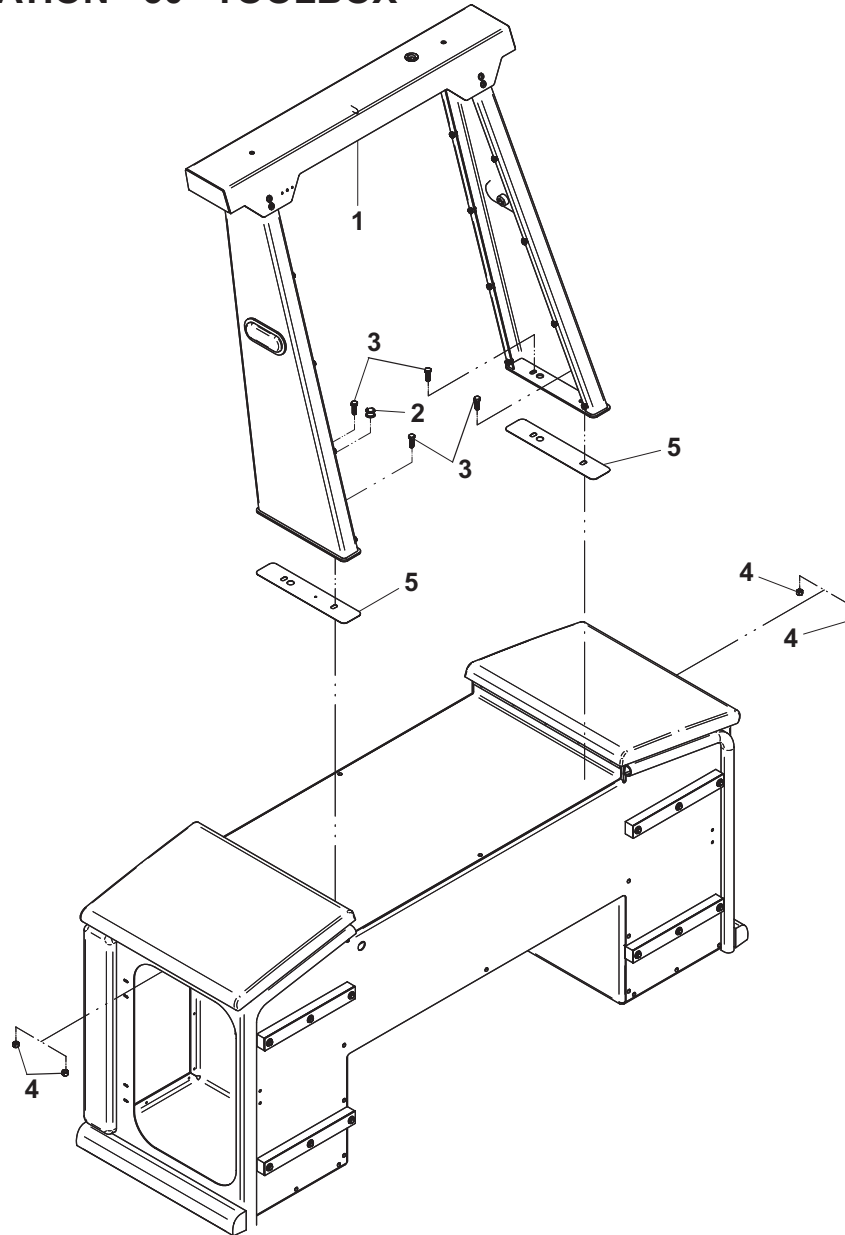

LIGHT PYLON ASSEMBLY - 38", 43" & 51"

ITEM	PART NO.	DESCRIPTION	QTY	ITEM	PART NO.	DESCRIPTION	QTY
38" Light Pylon				51" Light Pylon			
1	3263000089	Channel Weld, LH	1	1	3263000137	Channel Weld, LH	1
2	3263000090	Channel Weld, RH	1	2	3263000138	Channel Weld, RH	1
3	4263000452	Channel	1	3	4263000823	Channel	1
4	7114160850	Capscrew, 0.38" - 16NC x 1.00"	4	4	7114160850	Capscrew, 0.38" - 16NC x 1.00"	4
5	7950160141	Flatwasher, 0.38" ID	8	5	7950160141	Flatwasher, 0.38" ID	8
6	7660162601	Locknut, 0.38" - 16NC	12	6	7660162601	Locknut, 0.38" - 16NC	12
7	3263000088	Channel Weld,	1	7	3263000139	Channel Weld,	1
8	7114160818	Capscrew, 0.38"- 16NC x 1.00"	8	8	7114161018	Capscrew, 0.38" - 16NC x 1.25"	8
9	7950160153	Flatwasher, 0.38" ID	16	9	7950160153	Flatwasher, 0.38" ID	16
10	4706002942	Plate, LH	1	10	4706006027	Plate, LH	1
11	4706002941	Plate, RH	1	11	4706006028	Plate, RH	1
12	7114140818	Capscrew, 0.25" - 20NC x 1.00"	20	12	7114140818	Capscrew, 0.25" - 20NC x 1.00"	20
13	7950140500	Lockwasher, 0.25" ID	20	13	7950140500	Lockwasher, 0.25" ID	20
14	7950140153	Flatwasher, 0.25" ID	20	14	7950140153	Flatwasher, 0.25" ID	20
15	7661000042	Nut-U, 0.25" - 20NC	20	15	7661000042	Nut-U, 0.25" - 20NC	20
16	7493000011	Grommet	3	16	7493000011	Grommet	3
17	7493000017	Grommet	1	17	7493000017	Grommet	1
43" Light Pylon							
1	3263000093	Channel Weld, LH	1				
2	3263000094	Channel Weld, RH	1				
3	4263000452	Channel					
4	7114160850	Capscrew, 0.38" - 16NC x 1.00"	4				
5	7950160141	Flatwasher, 0.38" ID	8				
6	7660162601	Locknut, 0.38" - 16NC	12				
7	3263000088	Channel Weld,	1				
8	7114160818	Capscrew, 0.38"- 16NC x 1.00"	8				
9	7950160153	Flatwasher, 0.38" ID	16				
10	4706003196	Plate, LH	1				
11	4706003197	Plate, RH	1				
12	7114140818	Capscrew, 0.25" - 20NC x 1.00"	20				
13	7950140500	Lockwasher, 0.25" ID	20				
14	7950140153	Flatwasher, 0.25" ID	20				
15	7661000042	Nut-U, 0.25" - 20NC	20				
16	7493000011	Grommet	3				
17	7493000017	Grommet	1				

LIGHT PYLON ASSEMBLY - 38", 43" & 51"

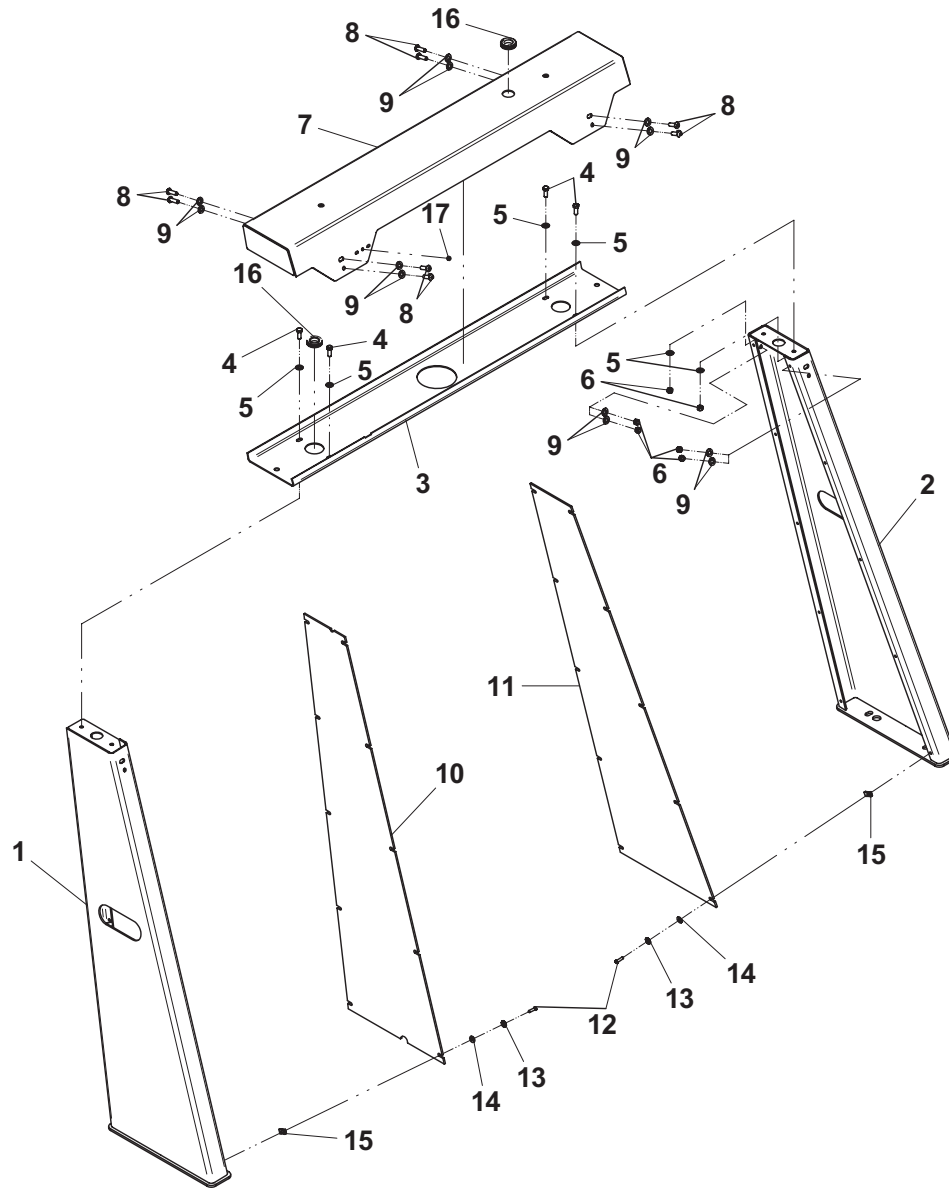

BODY LIGHT AND WIRING INSTALLATION

ITEM	PART NO.	DESCRIPTION	QTY	ITEM	PART NO.	DESCRIPTION	QTY
1	7590000204	Light	1	37	4811000289	Sheet	2
2	7590000205	Light	1	38	4811000364	Sheet	1
3	7552000167	Harness	1	39	7111140813	Screw, 0.25" - 20NC x 1.00"	24
4	7188000001	Bulb	2	40	7950140500	Lockwasher, 0.25" ID	24
5	7188000002	Bulb	2	41	7413000002	Nutset, 0.25" - 20NC	24
6	7661000024	Nut, #10 - 24NC	8	42	4811001378	Sheet	1
7	7114101210	Screw, #10 - 24NC x 1.50"	8				
8	7552000171	Harness	1				
9	7493000014	Grommet	2				
10	7493000017	Grommet	2				
11	7346000076	Gasket	2				
12	7590000104	Light	2				
13	7346000077	Guard	2				
14	7114100610	Screw, #10 - 24NC x 0.75"	8				
15	7661000002	Nut, #10 - 24NC	8				
16	7590000105	Light	1				
17	7178000025	License Plate Bracket	1				
18	7274000036	Clamp	2				
19	7114100618	Capscrew, #10 - 24NC x 0.75"	2				
20	7660102601	Nut, #10 - 24NC	2				
21	7552000168	Harness	1				
22	7552000169	Harness	2				
23	7346000019	Breaker	1				
24	7115140650	Capscrew, 0.25" - 20NC x 0.75"	2				
25	7950140151	Nut	2				
26	7660142601	Locknut, 0.25" - 20NC	2				
27	7345222202	Terminal	2				
28	7345242202	Terminal	1				
29	8977540200	Wire	3				
30	8594100003	Loom	3				
31	7790141656	Screw, 0.25" - 20NC x 1.00"	10				
32	7894000031	Cable	10				
33	7894000042	Tie Strap	22				
34	7590000094	Light	4				
35	7790100856	Screw, #10 x 0.50"	16				
36	7590000185	Light	2				

BODY LIGHT AND WIRING INSTALLATION

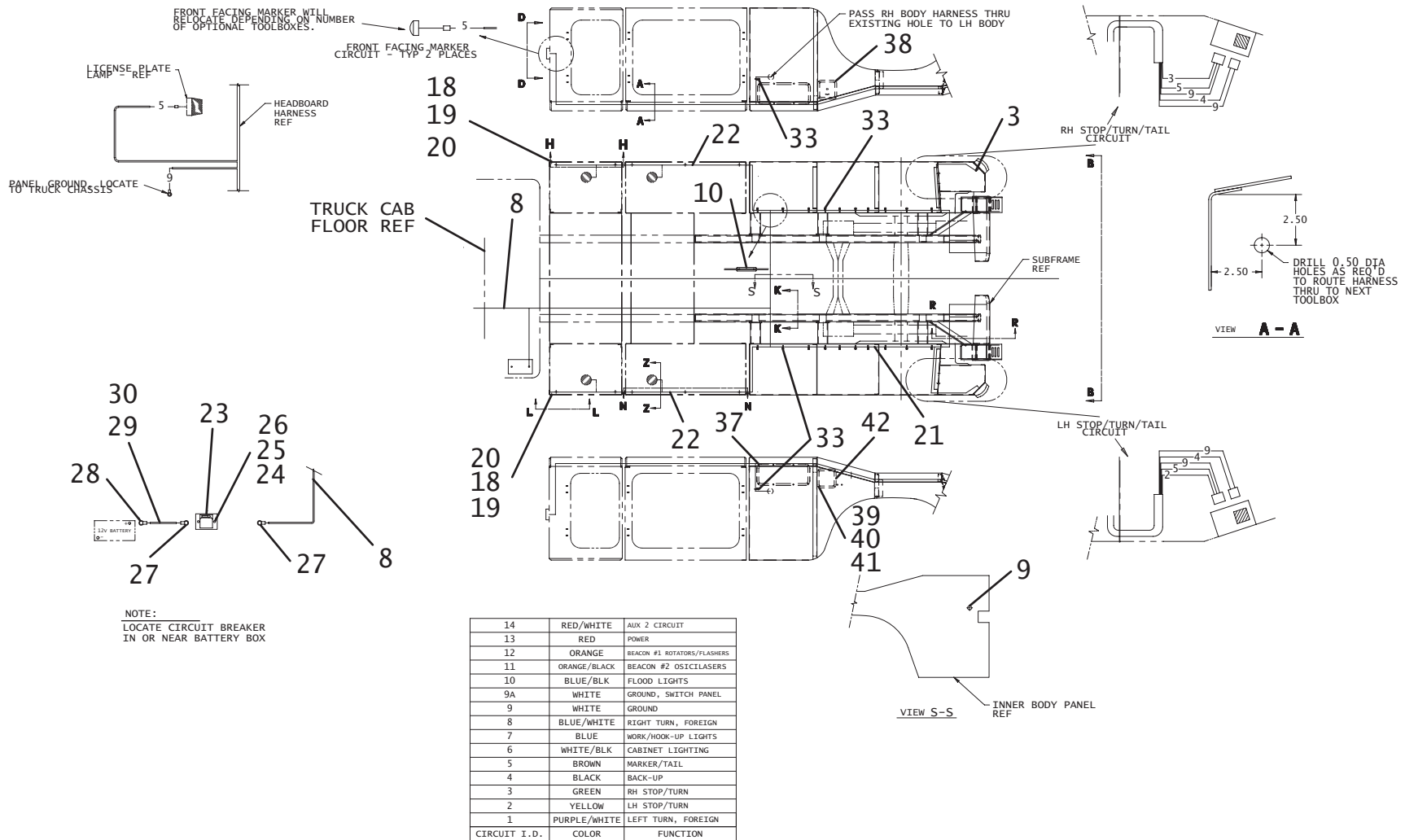

BODY LIGHT AND WIRING INSTALLATION

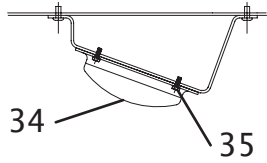

NOTE:
ONLY (1) REARMOST LIGHT
TO BE SUPPLIED PER BOX,
PER SIDE

SECTION **Z-Z**
SCALE: 0.38

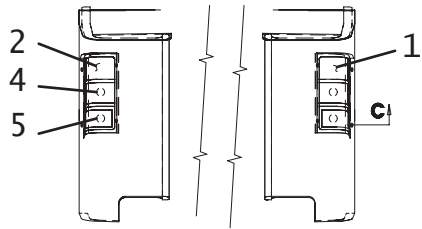

VIEW **B-B**

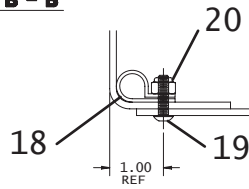

SECTION **M-M**

USING ITEMS 1 AND 2 AS
TEMPLATES DRILL 0.25 DIA
HOLES (TYP-8 PLACES) IN
BODY AND INSTALL ITEM 6

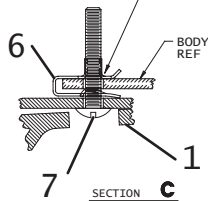

SECTION **C**

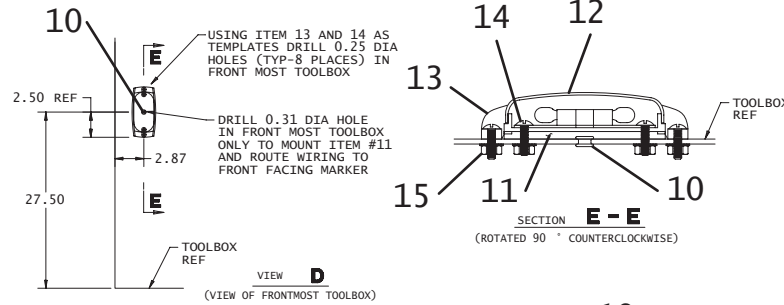

VIEW **D**
(VIEW OF FRONTMOST TOOLBOX)

USING ITEM 13 AND 14 AS
TEMPLATES DRILL 0.25 DIA
HOLES (TYP-8 PLACES) IN
FRONT MOST TOOLBOX

DRILL 0.31 DIA HOLE
IN FRONT MOST TOOLBOX
ONLY TO MOUNT ITEM #11
AND ROUTE WIRING TO
FRONT FACING MARKER

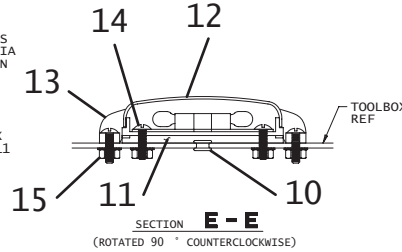

SECTION **E-E**
(ROTATED 90 ° COUNTERCLOCKWISE)

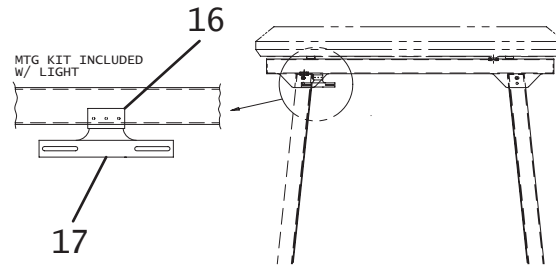

MTG KIT INCLUDED
W/ LIGHT

VIEW **K-K**

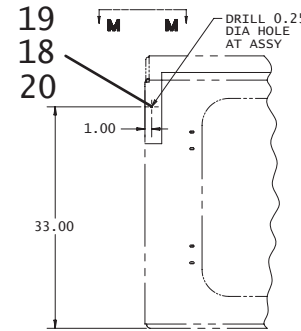

VIEW **L-L**

DRILL 0.25
DIA HOLE
AT ASSY

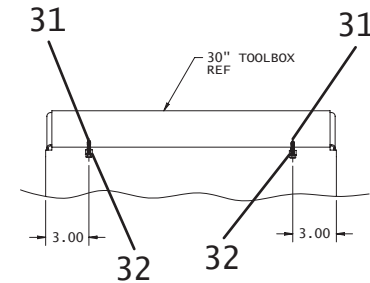

VIEW **H-H**
30" TOOLBOX ONLY

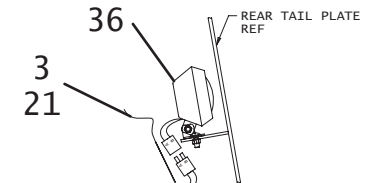

SECTION **R-R**

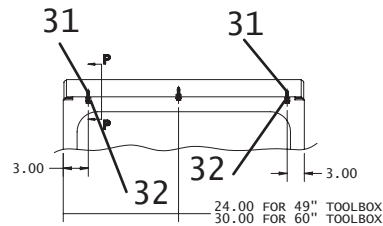

SECTION **N-N**
49" & 60" TOOLBOX'S ONLY

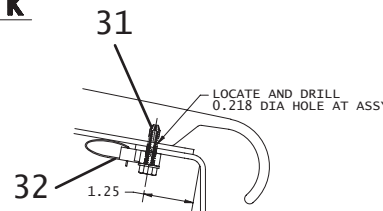

SECTION **P-P**

LOCATE AND DRILL
0.218 DIA HOLE AT ASSY

CAVITY	RH BODY CIRCUIT	FUNCTION
A	9	GROUND
B	7	WORK

CAVITY	LH BODY CIRCUIT	FUNCTION
A	9	GROUND
B	7	WORK

THIS PAGE INTENTIONALLY LEFT BLANK

HEADBOARD LIGHT AND WIRING INSTALLATION

ITEM	PART NO.	DESCRIPTION	QTY
1	7552000170	Harness	1
2	7590000127	Light, Dome 4"	1
3	7493000002	Grommet	1
4	70050214	Light	2
5	7493000014	Grommet	1
6	7115141450	Capscrew, 0.25" - 20NC x 1.75"	1
7	7894000031	Cable Tie	1
8	7660150230	Nut, 0.31" - 24NF	1
9	7493000026	Grommet	1

HEADBOARD LIGHT AND WIRING INSTALLATION

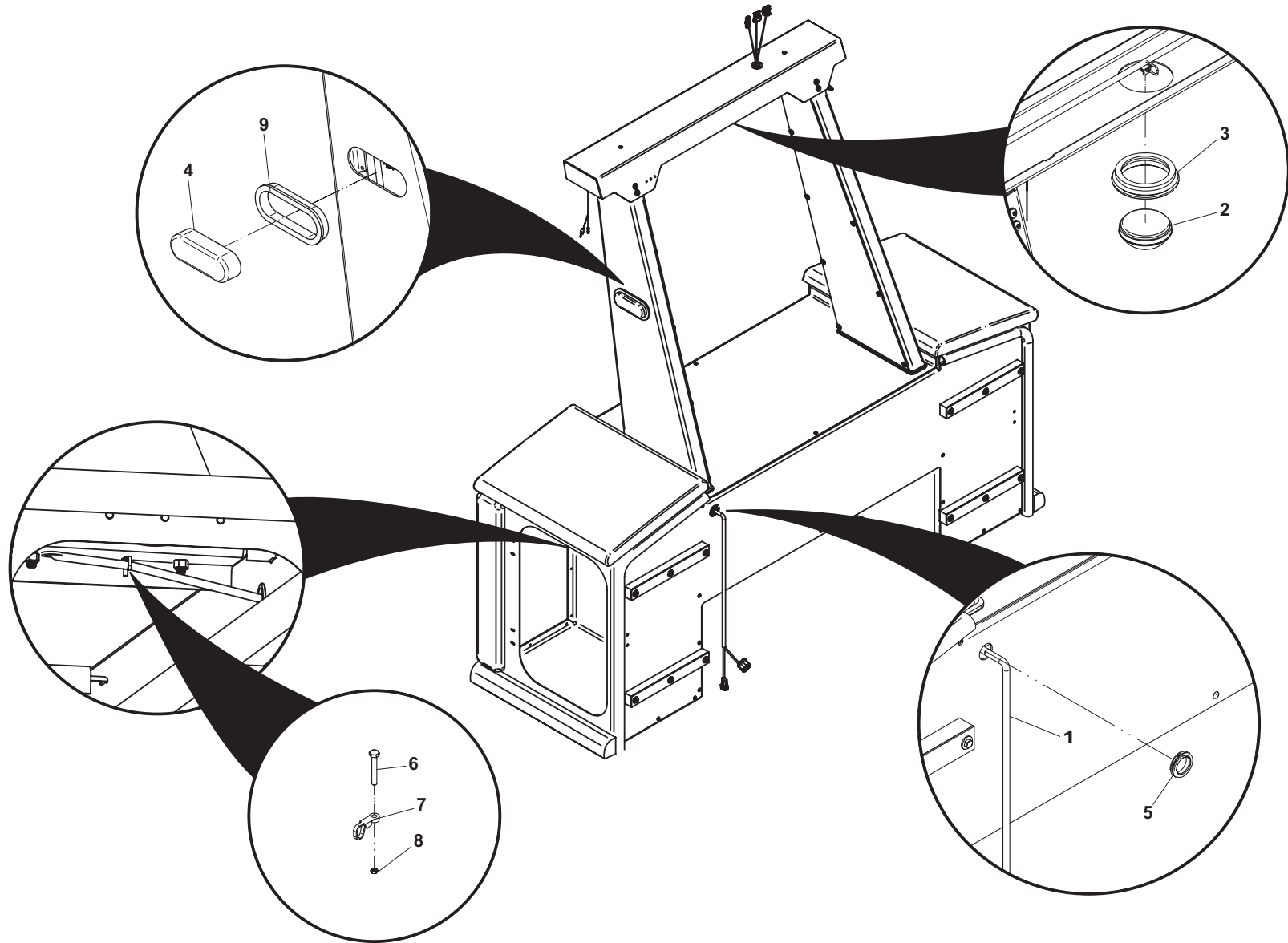

LIGHTBAR INSTALLATION

ITEM	PART NO.	DESCRIPTION	QTY
1	1001136990	Lamp, 58" Code 3 LED	1
	1001129872	Lamp, 60" Whelen LED	
2	4178000402	Bracket	2
3	4706001478	Plate	2
4	7660182601	Locknut, 0.50" - 13NC	2
5	7115181450	Capscrew, 0.50" - 13NC x 1.75"	2
6	7346000039	Tube, 0.25" Dia.	6in

LIGHTBAR INSTALLATION

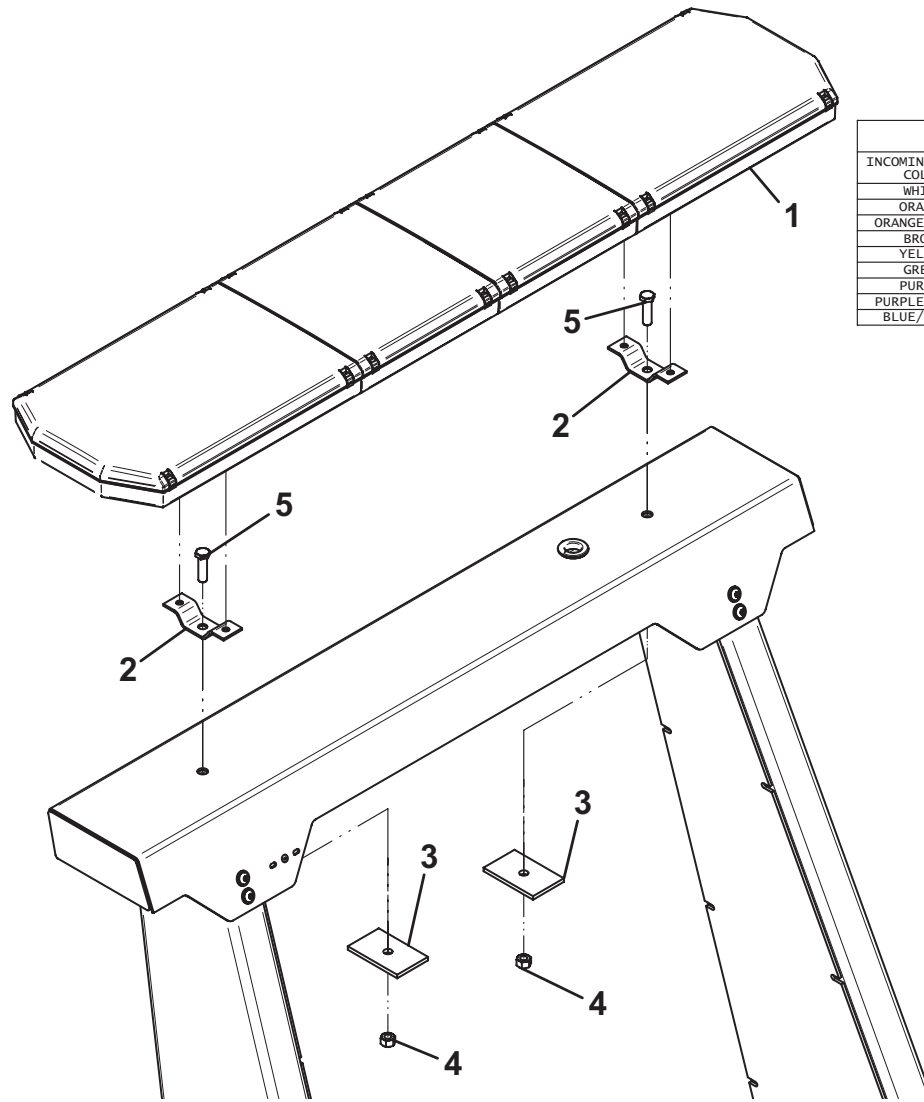

Item 6, not shown

WIRE HARNESS INFO.		
INCOMING CABLE COLOR	OPTION	WIRE INFO
WHITE	COMMON GROUND	10 GA. WIRE
ORANGE	BEACON 1	12 GA. WIRE
ORANGE/BLACK	BEACON 2	12 GA. WIRE
BROWN	MARKER/TAIL	16 GA. WIRE
YELLOW	LH STOP/TURN	16 GA. WIRE
GREEN	RH STOP/TURN	16 GA. WIRE
PURPLE	WORKLIGHT, LIGHTBAR	16 GA. WIRE
PURPLE/WHITE	LEFT TURN (FOREIGN)	16 GA. WIRE
BLUE/WHITE	RIGHT TURN (FOREIGN)	16 GA. WIRE

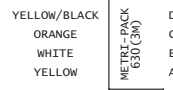
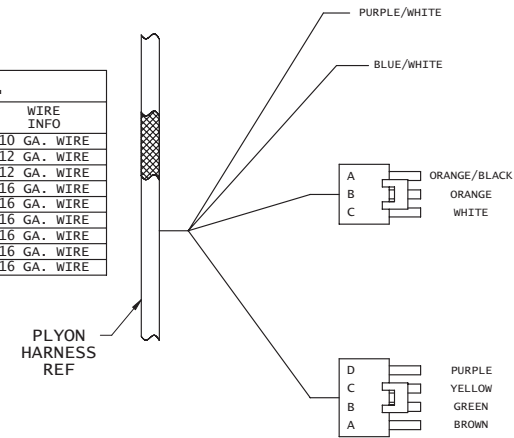

LIGHTBAR HARNESS REF

LIGHT BAR WIRE INFO.		
INCOMING CABLE COLOR	OPTION	WIRE INFO
BLACK	COMMON GROUND	10 GA. WIRE
RED	OUTBOARD LED	14 GA. WIRE
RED/BLACK	CENTER LED	14 GA. WIRE
YELLOW	TAIL-LIGHTS / D.O.T. STRIP	16 GA. WIRE
ORANGE	L.H. STOP/TURN	16 GA. WIRE
WHITE	R.H. STOP/TURN	16 GA. WIRE
YELLOW/BLACK	WORKLIGHTS	16 GA. WIRE
BLUE	NOT USED	16 GA. WIRE
BLUE/BLACK	NOT USED	16 GA. WIRE

LIGHTBAR - CODE 3 - 1001136990

ITEM	PART NO.	DESCRIPTION	QTY
1	9590310197	Lens, Clear Upper Outboard	2
2	9590310200	Lens, Clear Lower Outboard	2
3	9590310203	Lens, Clear Lower Center	2
4	9590310195	Lens, Clear Upper Center	2
5	1001126269	3 Light D.O. T. Strip	1
6	70050164	Worklight, LED	2
7	1001130702	Module, LED Stop/Tail/Turn	2
8	70050166	Bracket, Blank	4
9	9590310206	Module, Corner LED Amber & Bracket	4
10	9590310205	Module, LED Amber	6
11	9590310202	Bracket, Mounting	6
12	70050167	Controller, General	1
13	70050165	Cable, Jerr-Dan 9 Wire	1

LIGHTBAR - CODE 3 - 1001136990

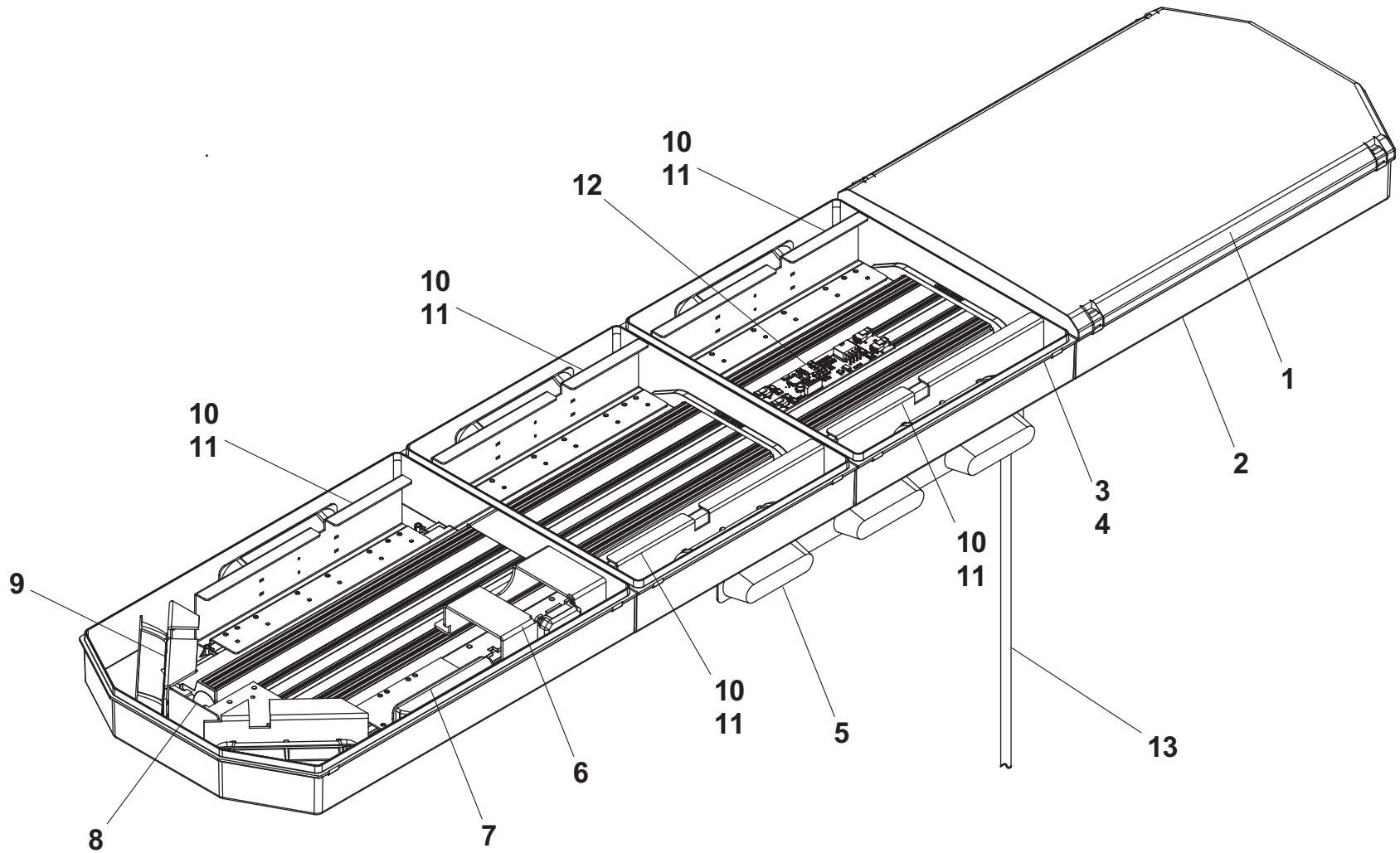

LIGHTBAR - WHELEN - 1001129872

ITEM	PART NO.	DESCRIPTION	QTY	ITEM	PART NO.	DESCRIPTION	QTY
1	70050168	Base	1	35	70050201	Assembly, Lens Divider	8
2	70050169	Grommet	1	36	70050202	Subassembly, End Cap Clear	2
3	70050170	Plug, Vent	2	37	70050203	Screw, #10-24NC x 1.25"	8
4	70050163	Assembly, HC I/O Liberty	1	38	70050204	Kit, Rotational Mtg. Adapter	2
5	70050171	Cable, 9-Wire	1	39	70050205	Label, "Front" Lightbar Assembly	1
6	70050172	Screw, #10-24NC x 1.00"	1	40	70050206	Label, Jerr-Dan Logo	1
7	70050173	Clamp, Cable	1	41	70050207	Label, Model & Serial Number	1
8	70050174	Wiz Nut, #10-24NC	1	42	70050208	Assembly, Housing	1
9	70050175	Housing, 6-Position Socket	2	43	70050209	Connector	1
10	70050176	Grommet	1	44	70050210	Housing, Lock	1
11	70050177	Subassembly, ICC Light Cluster	1	45	70050211	Housing	1
12	70050178	Harness, ICC Light	1				
13	70050179	Screw, #10-24NC x 0.50"	2				
14	70050180	Lockwasher, #10 ID	2				
15	70050181	Housing	1				
16	70050182	Housing, Lighthouse	12				
17	70050183	Subassembly, LR11 TD Single	2				
18	70050184	Harness	2				
19	70050185	Harness, Brake/Tail/Turn	1				
20	70050186	Harness, Take Down/Work	1				
21	70050187	Subassembly, 500 4-LED Amber	6				
22	70050188	Assembly, 500 BTT Max	2				
23	70050189	Panel, Filler	4				
24	70050190	Subassembly, End Support Bracket	2				
25	70050191	Insulator, Foam Pad	1				
26	70050192	Label, Wiring Schematic	1				
27	70050193	Top, Extruded	1				
28	70050194	Screw, #10-24NC x 0.38"	4				
29	70050195	Spacer, Corner	4				
30	70050196	Assembly, Corner 9-LED Amber	4				
31	70050197	Spacer, Corner Retention	4				
32	70050198	Lens, Clear Optic Center	2				
33	70050199	Lens, Clear-15.80"	4				
34	70050200	Lens, Clear-8.38"	4				

LIGHTBAR - WHELEN - 1001129872

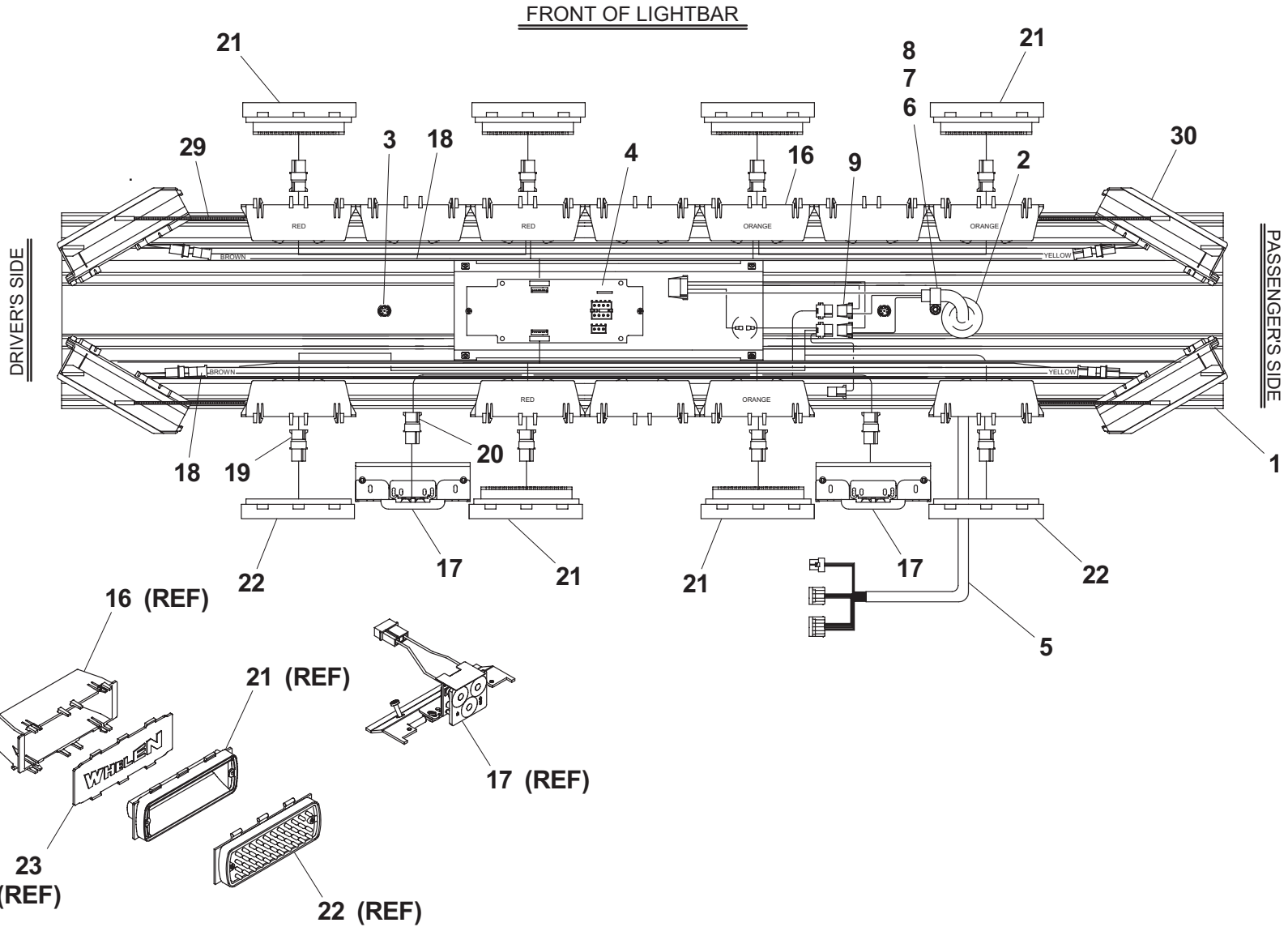

LIGHTBAR - WHELEN - 1001129872

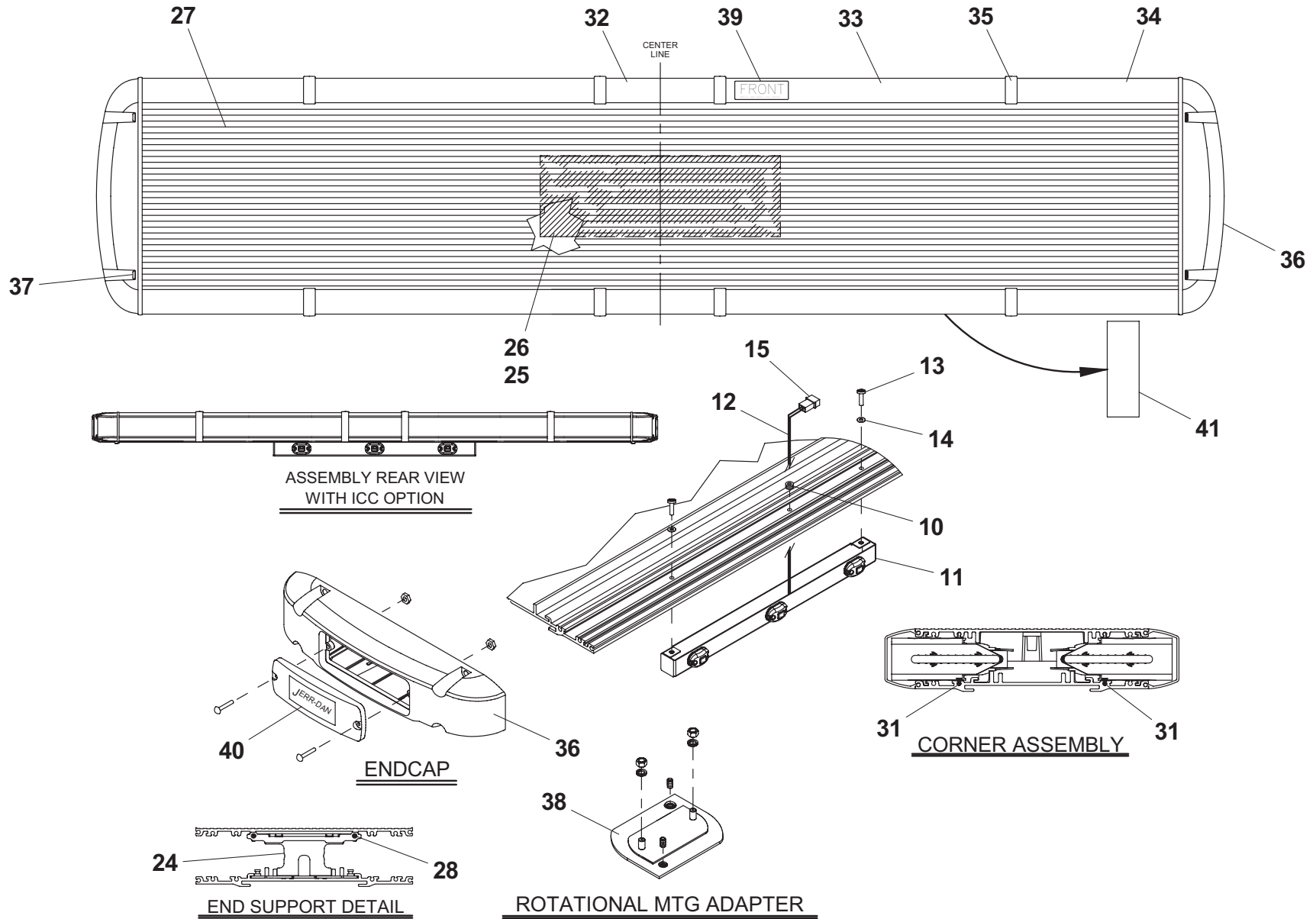

THIS PAGE INTENTIONALLY LEFT BLANK

SUPPLY PRESSURE AND RETURN ASSEMBLY

ITEM	PART NO.	DESCRIPTION	QTY
1	7650100137	Pipe Nipple	1
2	7935000116	Ball Valve	1
3	7444121271	Elbow, 1.50"	1
4	7443000254	Fitting	2
5	7274000028	Clamp	2
6	8565000026	Hose	12ft
7	7444121050	Reducer Bushing	1
8	4567132156	Hose	1
9	7445081243	Adapter	1
10	7445081245	Elbow	1
11	7247000040	Clamp	20
12	7274000071	Clamp	10
13	7115140850	Capscrew, 0.25" - 20NC x 1.00"	20
14	7950140152	Washer, 0.25" ID	20
15	7660142601	Locknut, 0.25" - 20NC	20
16	4706003844	Plate	10
17	4567130155	Hose	1
18	4178000349	Bracket	1
19	7950200161	Flatwasher, 0.63" ID	5
20	7660202601	Locknut, 0.63" - 11NC	1
21	7430000010	In-Tank Filter	1
22	7443000441	Fitting	1
23	7274000076	Clamp	10
24	7785152420	Setscrew, 0.31" - 18NC x 1.50"	10
25	7660152601	Locknut, 0.31" - 18NC	20
26	7115151050	Capscrew, 0.31" - 18NC x 1.25"	10
27	7950150161	Flatwasher, 0.31" ID	10
28	7724000024	Pump (CCW Rotation)	1
	7724000153	Pump (CW Rotation)	1
29	7865182065	Stud, 0.50" - 13NC x 2.50"	4
30	7950180000	Lockwasher, 0.50" ID	4
31	7660180000	Nut, 0.50" - 13NC	4
32	7445081645	Elbow	2
33	7445242403	Adapter	1
34	7443000254	Fitting	1

SUPPLY PRESSURE AND RETURN ASSEMBLY

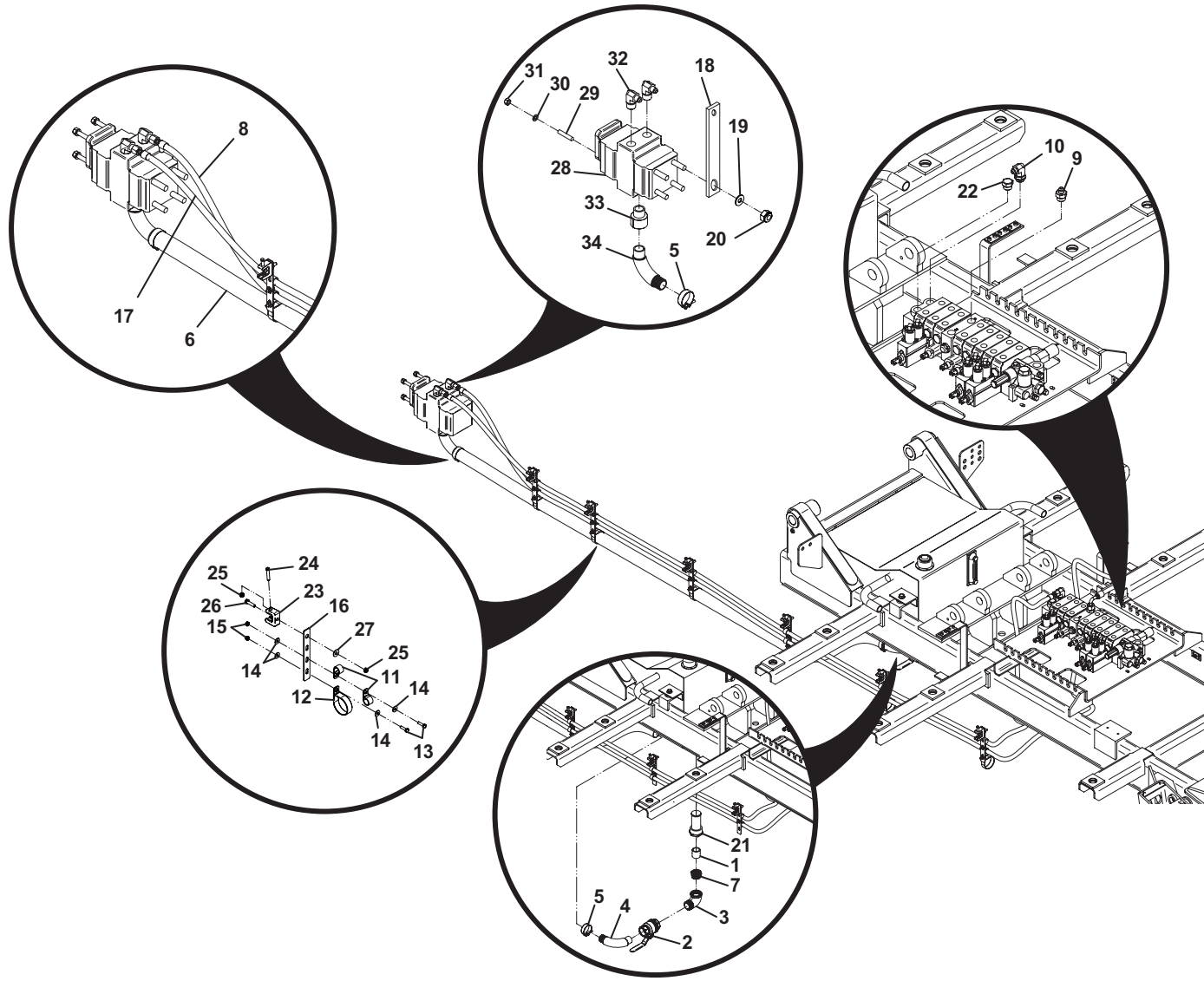

HYDRAULIC LINES AND FITTINGS

ITEM	PART NO.	DESCRIPTION	QTY	ITEM	PART NO.	DESCRIPTION	QTY
1	7445080843	Adapter	2	37	7445080845	Elbow	2
2	7445060645	Elbow	12	38	7819000005	Nylon Hose Sleeve, 6.00'	2
3	7445060646	Elbow	1	39	5526000553	Tie Strap	12
4	7445060643	Adapter	6	40	1001136447	Clamp	4
5	7935000308	Valve	4	41	7577000683^	Hydraulic Spade Hose Kit	1
6	7115151650	Capscrew, 0.31" - 18NC x 2.00"	10			Hydraulic Hose Kit - 7577000682	
7	7660152601	Locknut, 0.31" - 18NC	12	101	4567133026*	Hose Assembly	1
8	7950150161	Flatwasher, 0.31" ID	10	102	4567132026*	Hose Assembly	1
9	7445061043	Adapter	6	103	4567130031*	Hose Assembly	1
10	7445060637	Union	2	104	4567130032*	Hose Assembly	1
11	7445060647	Tee	3	105	4567122032*	Hose Assembly	1
12	7445040446	Elbow	2	106	4567120035*	Hose Assembly	1
13	7443000241	Fitting	2	107	4567122038*	Hose Assembly	1
14	7445040643	Adapter	2	108	4567122033*	Hose Assembly	1
15	7445060439	Reducer	4	109	4567123029*	Hose Assembly	1
16	7443000108	Restrictor	2	110	4567122027*	Hose Assembly	1
17	7935000307	Valve	2	111	4567120017*	Hose Assembly	2
18	7445040443	Adapter	4	112	4567120021*	Hose Assembly	2
19	7445040645	Elbow	8	113	4569121072*	Hose Assembly	2
20	7935000309	Valve	1	114	4569121073*	Hose Assembly	2
21	7118151620	Capscrew, 0.31" - 18NC x 2.00"	2	115	4567110046*	Hose Assembly	2
22	4706004511	Plate	1	116	4569121032*	Hose Assembly	3
23	7115151250	Capscrew, 0.31" - 18NC x 1.50"	2	117	4569121034*	Hose Assembly	1
24	7445060648	Tee	1	118	4569140031*	Hose Assembly	2
25	7445081045	Elbow	1	119	4569120025*	Hose Assembly	2
26	7443000240	Fitting	3	120	4569143023*	Hose Assembly	2
27	7445060845	Elbow	1	121	4567160042*	Hose Assembly	1
28	7443000231	Fitting	1	122	4567160053*	Hose Assembly	1
29	7445121245	Elbow	2	123	4567122035*	Hose Assembly	1
30	7445121619	Adapter	2			Hydraulic Tube Kit - 7577000683	
31	7445060219	Adapter	1	201	4567112074^	Hose Assembly	4
32	7443000158	Fitting	2	202	4567112023^	Hose Assembly	4
33	7470000002	Oil Filter Gauge	2			Hydraulic Hose Kit - 1001127064	
34	7430000004	Oil Filter Assembly	2	301	1001127060#	Tube Assembly	2
35	7577000682*	Hydraulic Hose Kit	1	302	7912000078#	Tube Assembly	3
36	1001127064#	Hydraulic Tube Kit	1	303	7912000175#	Tube Assembly	1

HYDRAULIC LINES AND FITTINGS

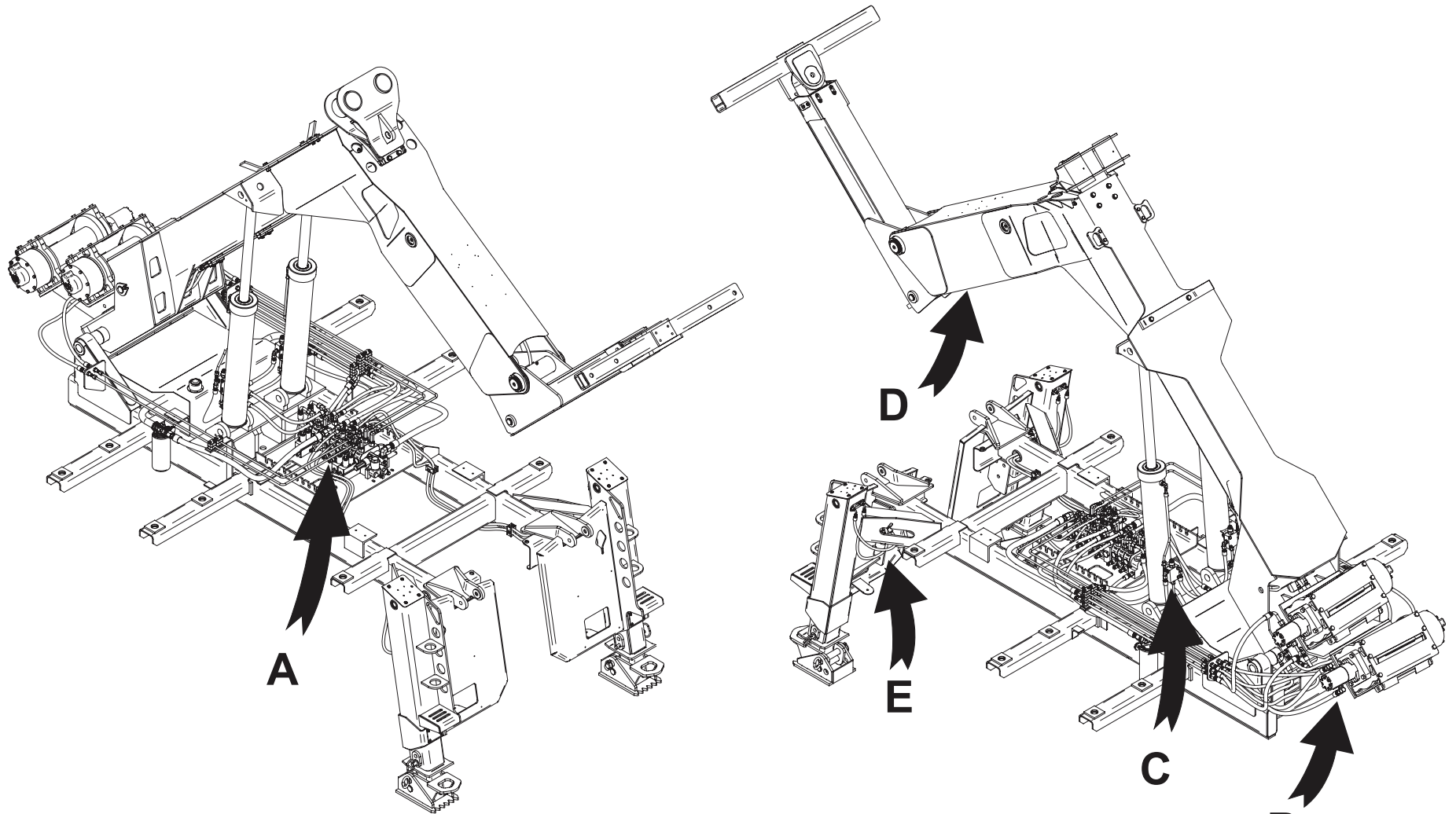

Items 35, 36, 41 are Hydraulic Hose and Tube Kits
Items 38 and 39 Not Shown

HYDRAULIC LINES AND FITTINGS

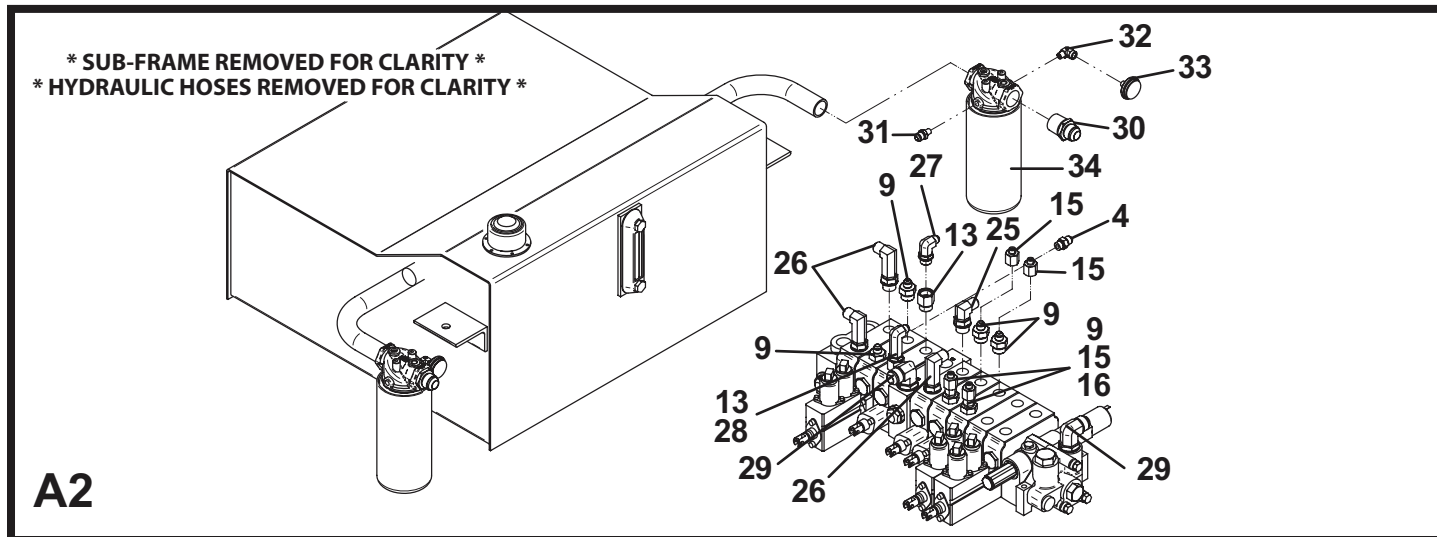
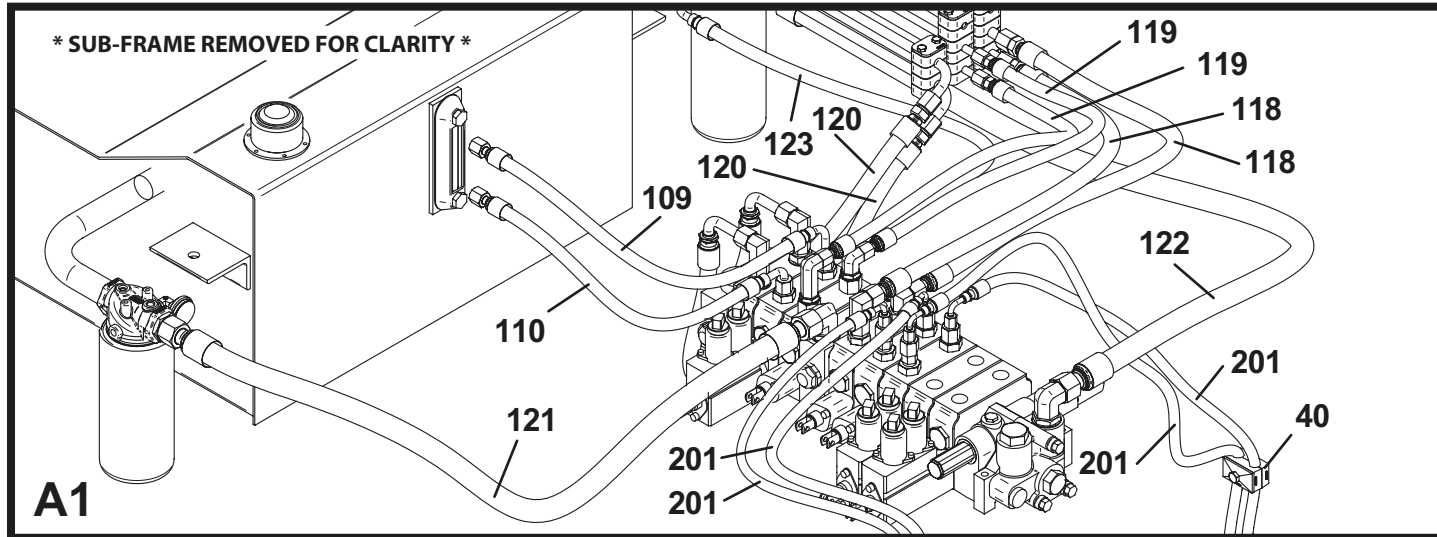

HYDRAULIC LINES AND FITTINGS

B1

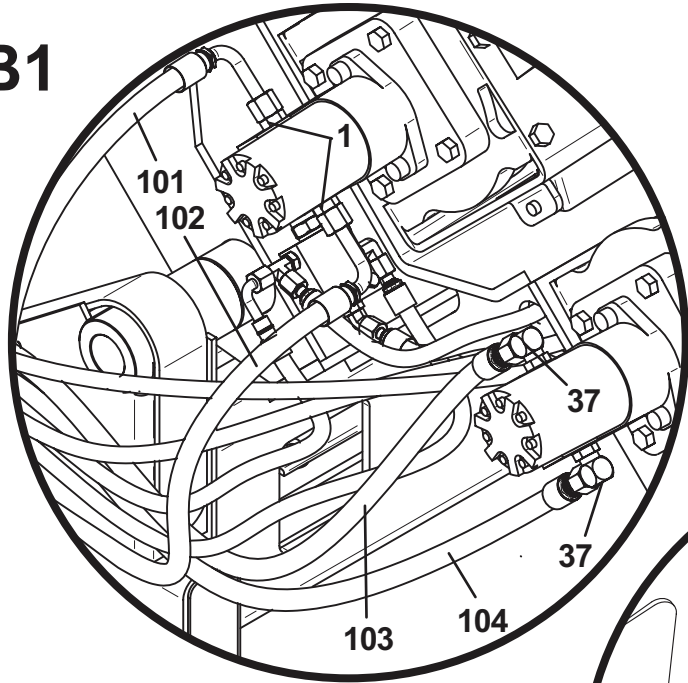

B2

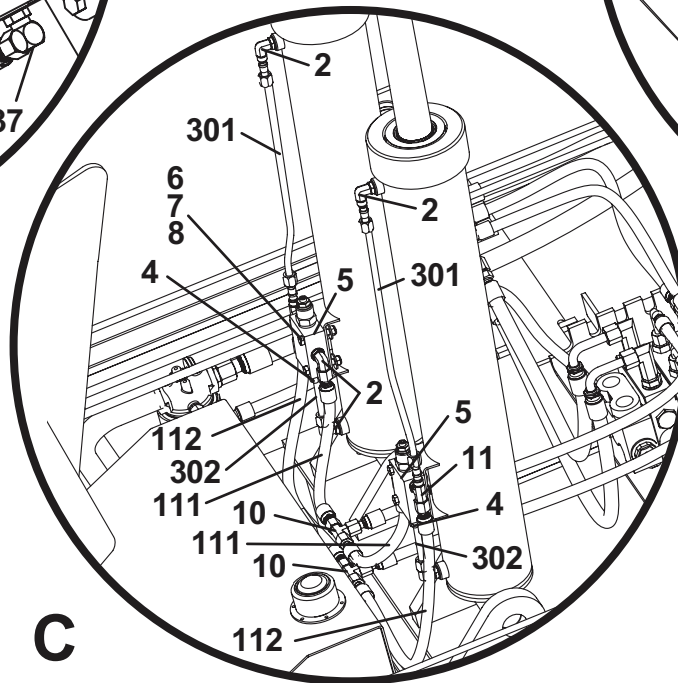
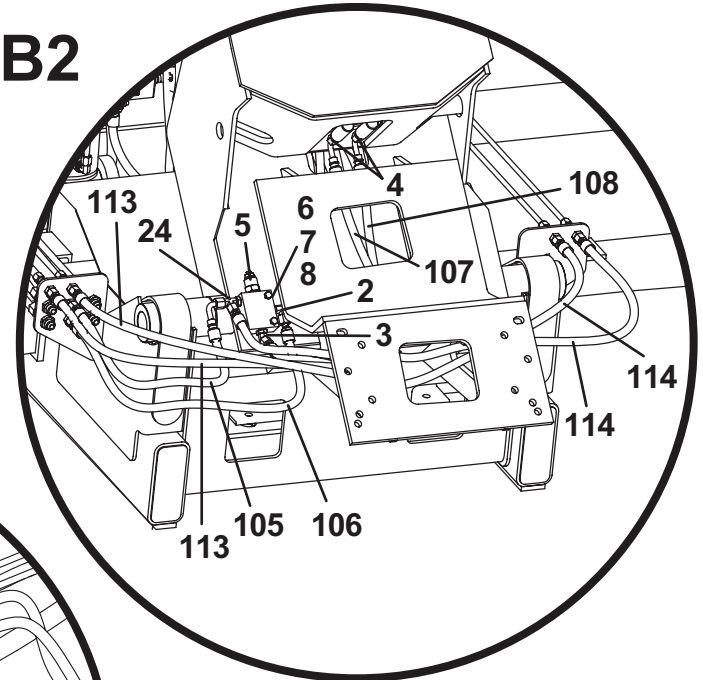

WINCHES REMOVED FOR CLARITY

HYDRAULIC LINES AND FITTINGS

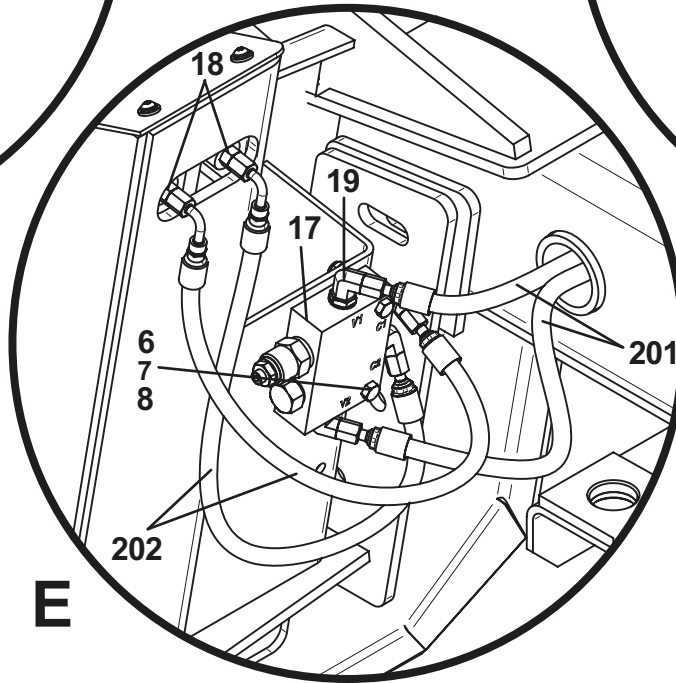
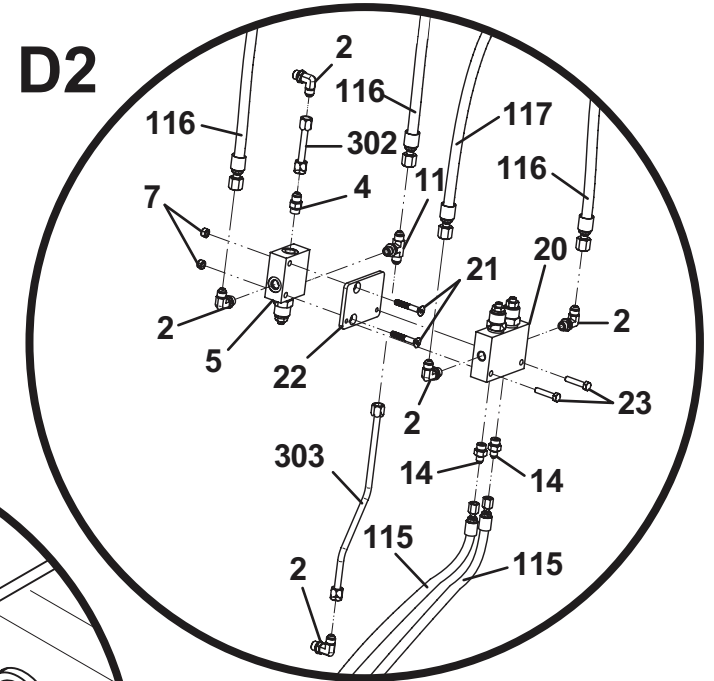
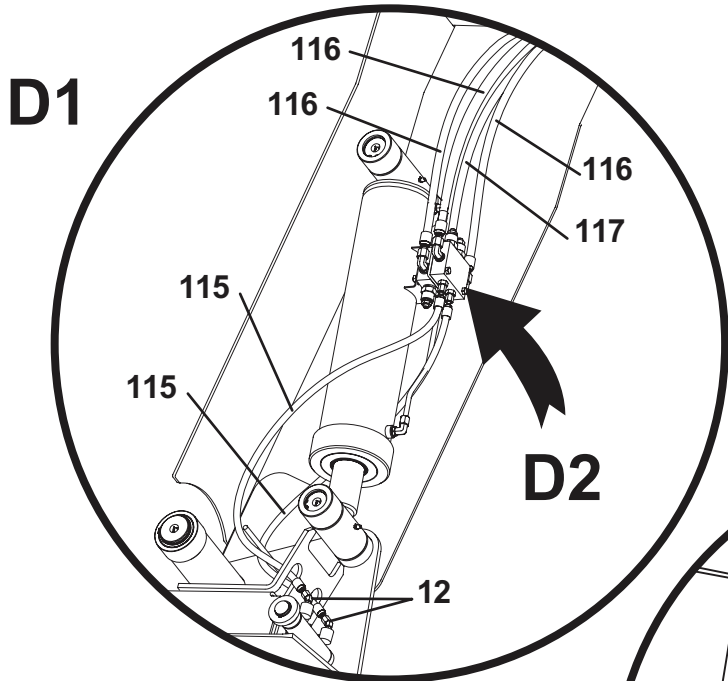

SIDE AND REAR PLATE REMOVED FOR CLARITY

HYDRAULIC LINES AND FITTINGS

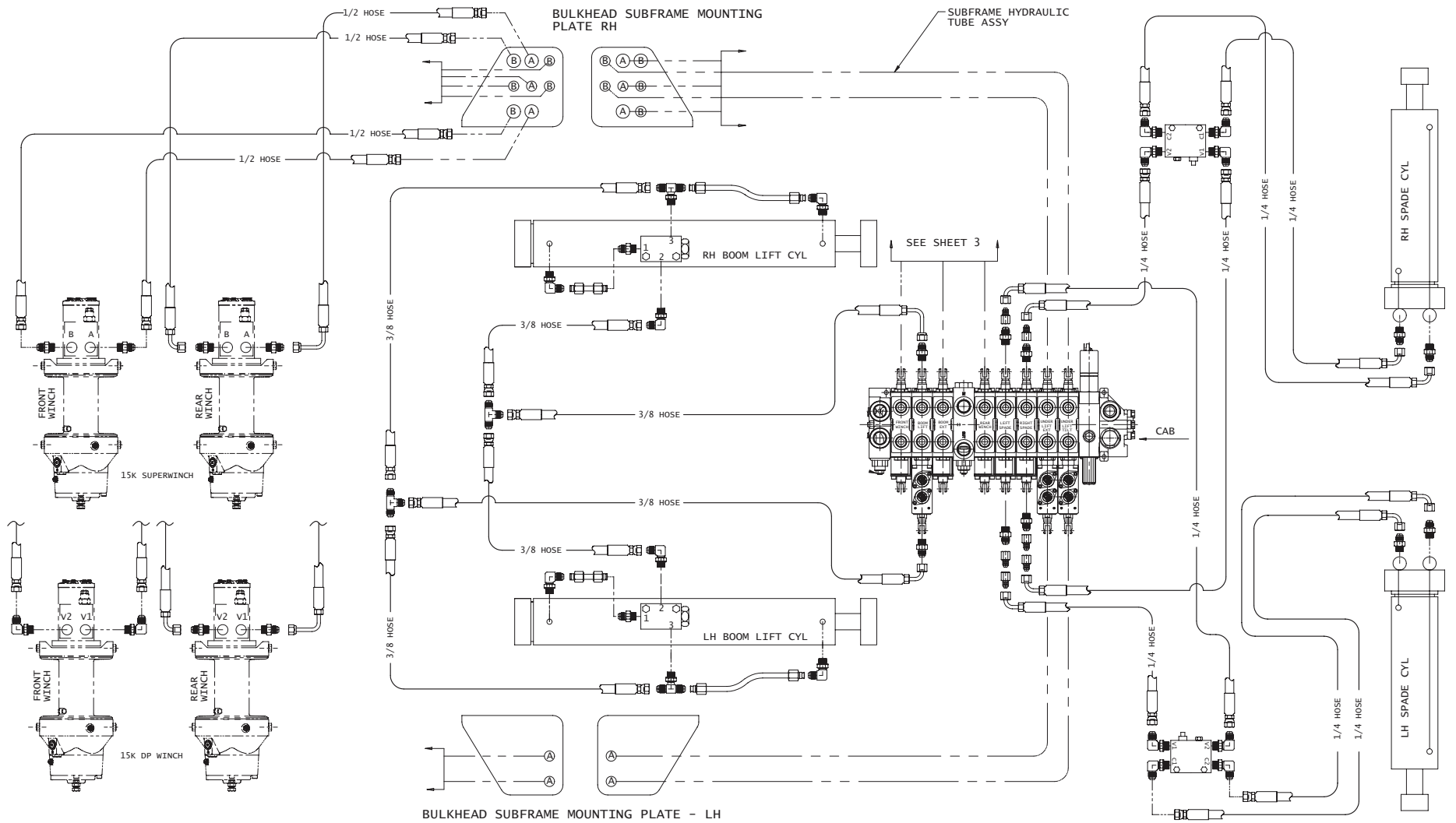

HYDRAULIC LINES AND FITTINGS

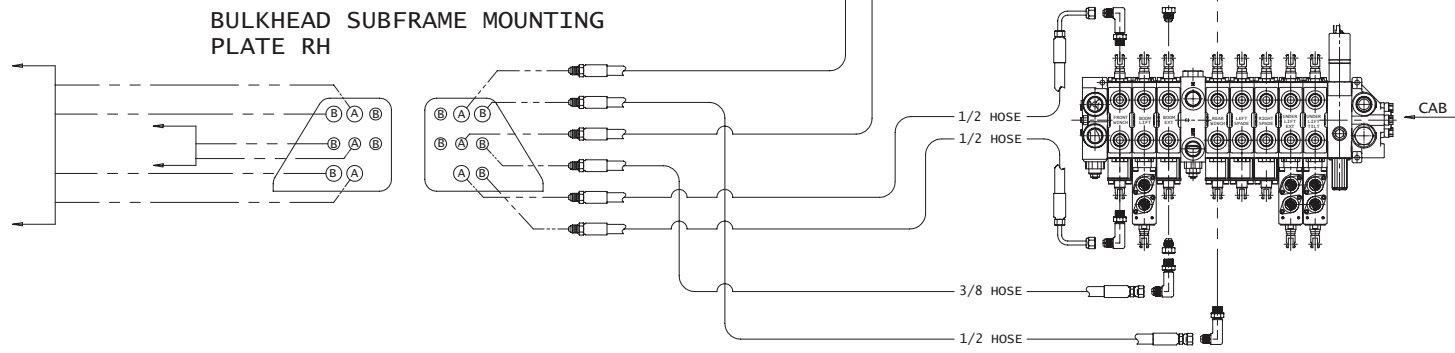
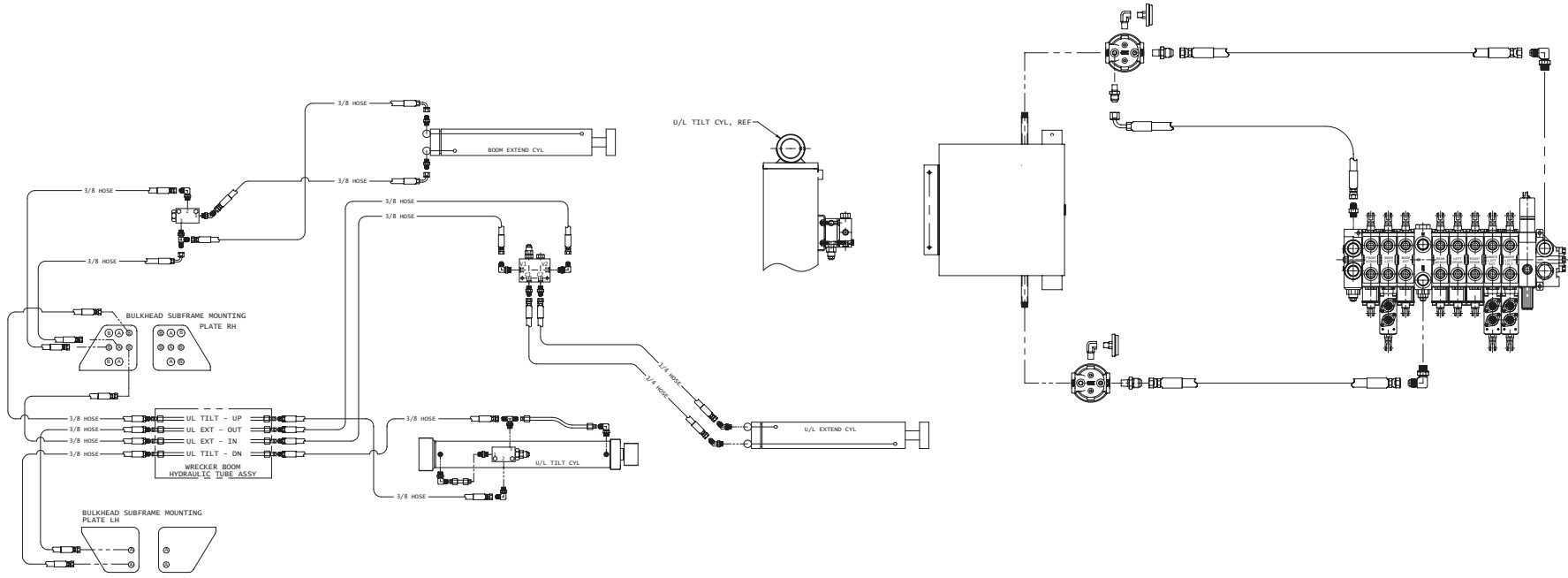

HYDRAULIC LINES AND FITTINGS

THIS PAGE INTENTIONALLY LEFT BLANK

CONTROLS AND VALVE ASSEMBLY

ITEM	PART NO.	DESCRIPTION	QTY	ITEM	PART NO.	DESCRIPTION	QTY
1	3178000284	Bracket, LH	1	37	7413000002	Nutsert, 0.25" - 20NC	12
2	3178000285	Bracket, RH	1	38	4706004056	Plate, RH	1
3	7115140650	Capscrew, 0.25" - 20NC x 0.75"	26	39	7330000859	Decal	1
4	7660142601	Locknut, 0.25" - 20NC	14	40	7950150161	Flatwasher, 0.31" ID	4
5	7115152450	Capscrew, 0.31" - 18NC x 3.00"	3	41	7115150850	Capscrew, 0.31" - 18NC x 1.00"	1
6	7660152601	Locknut, 0.31" - 18NC	3				
7	7935000293	Valve Assembly	1				
8	7248000061	Cables, 52"	10				
9	7660140234	Nut, 0.25" - 28NF	32				
10	4309000007	Cable Coupling, 5.38"	5				
11	4309000001	Cable Coupling, 1.56"	11				
12	7691000035	Pin, Clevis	32				
13	7691000036	Pin, Cotter	32				
14	7551000033	Handle, 9.38"	8				
15	7551000032	Handle, 7.83"	8				
16	7248000062	Cable, 56"	6				
17	4831000124	Spacer, 1.13"	4				
18	4831000122	Spacer, 1.94"	2				
19	7082000005	Bearing	8				
20	7691000066	Pin	4				
21	7754000009	Retaining Ring	8				
22	7990000003	End Yoke	16				
23	7950220161	Flatwasher, 0.75" ID	4				
24	4811000338	Sheet	1				
25	4811000339	Sheet	1				
26	7636000011	Plug	8				
27	7950140141	Flatwasher, 0.25" ID	30				
28	7950150000	Washer, 0.31" ID	1				
29	4706004055	Plate, LH	1				
30	7114100827	Capscrew, #10 - 24NC x 1.00"	8				
31	7950100143	Flatwasher, 0.19" ID	8				
32	7330000858	Decal, LH	1				
33	4811000348	Sheet	2				
34	7115140450	Capscrew, 0.25" - 20NC x 0.50"	6				
35	4493000003	Grommet	16				
36	7950140000	Lockwasher, 0.25"	6				

CONTROLS AND VALVE ASSEMBLY

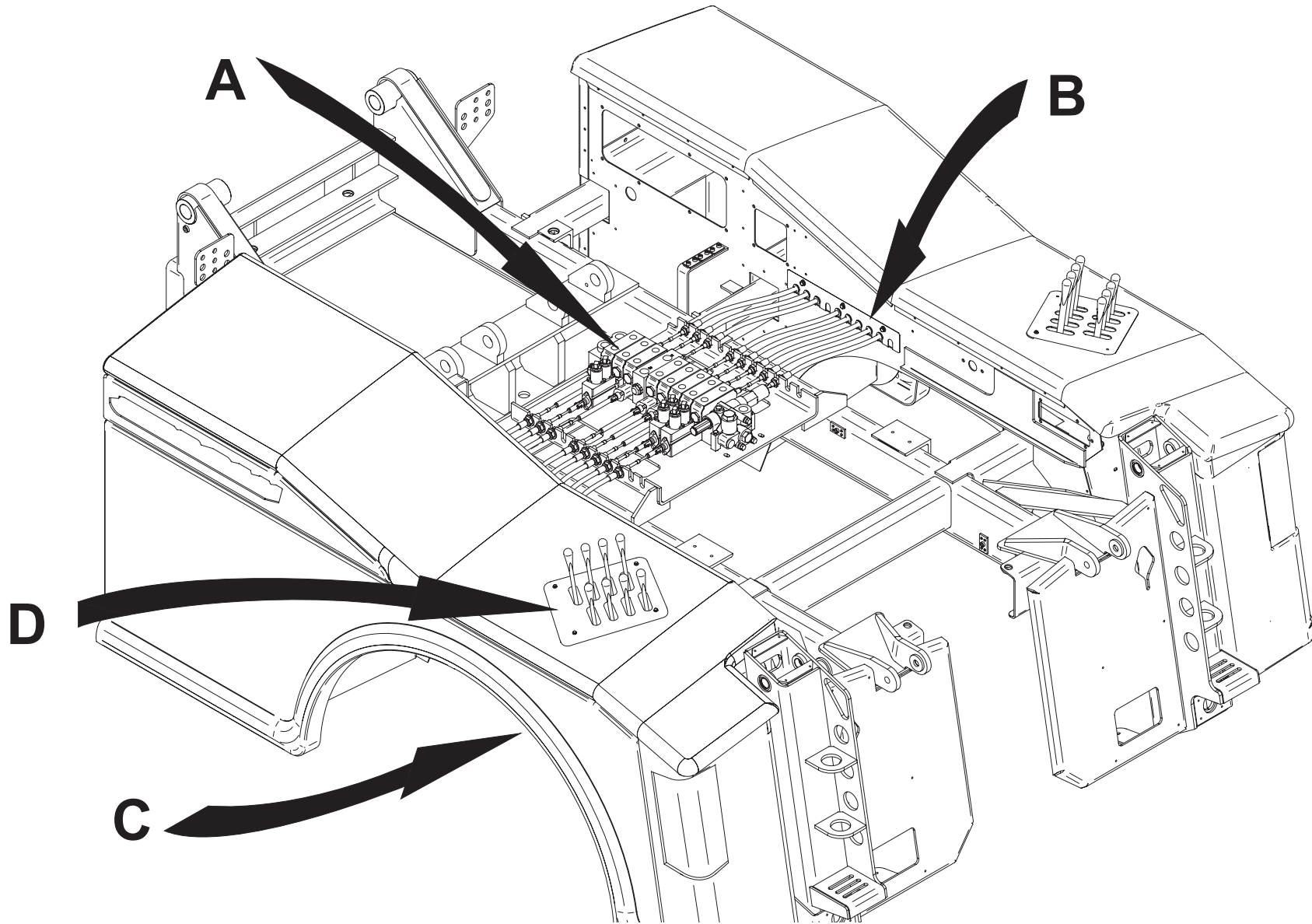

CONTROLS AND VALVE ASSEMBLY

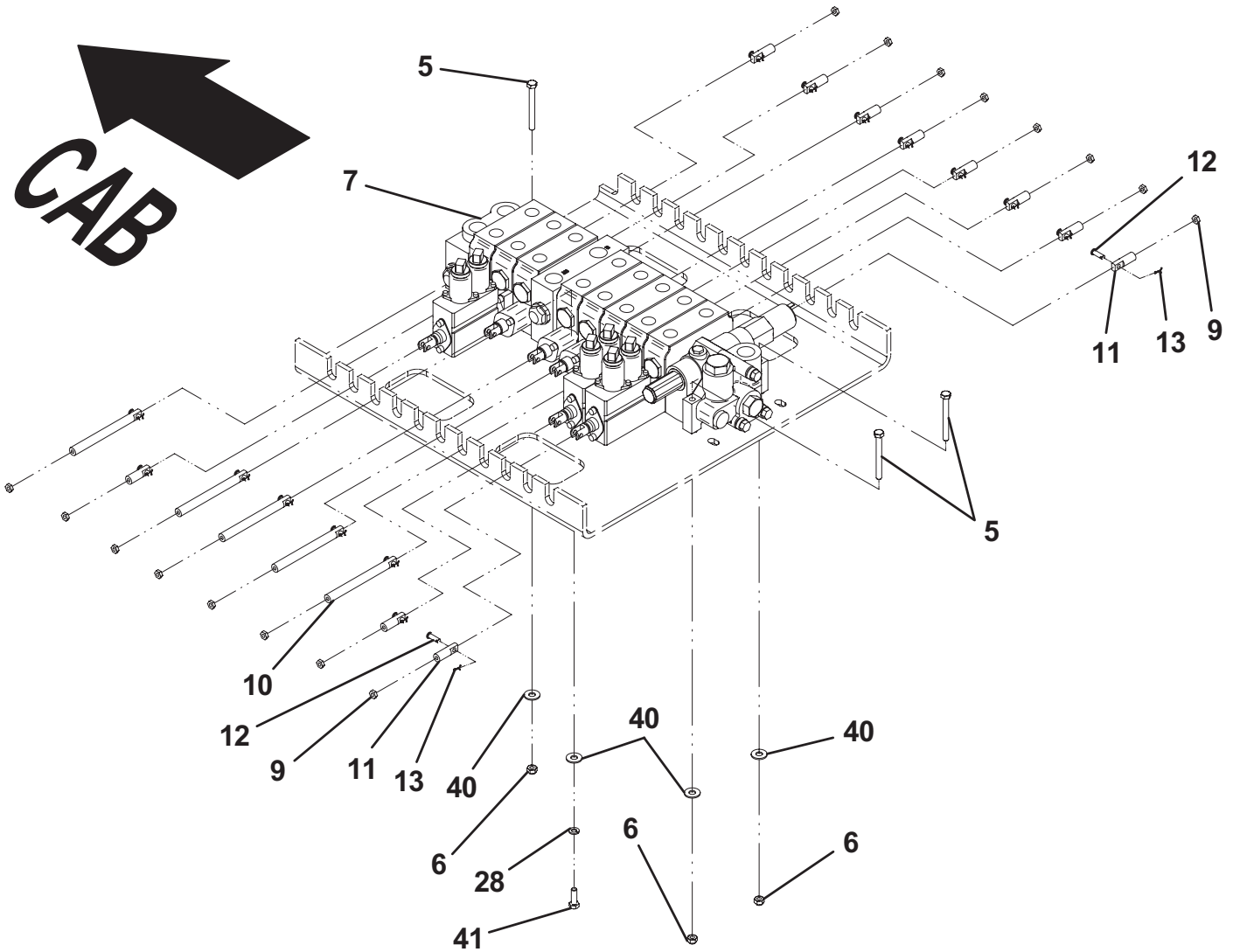

A

CONTROLS AND VALVE ASSEMBLY

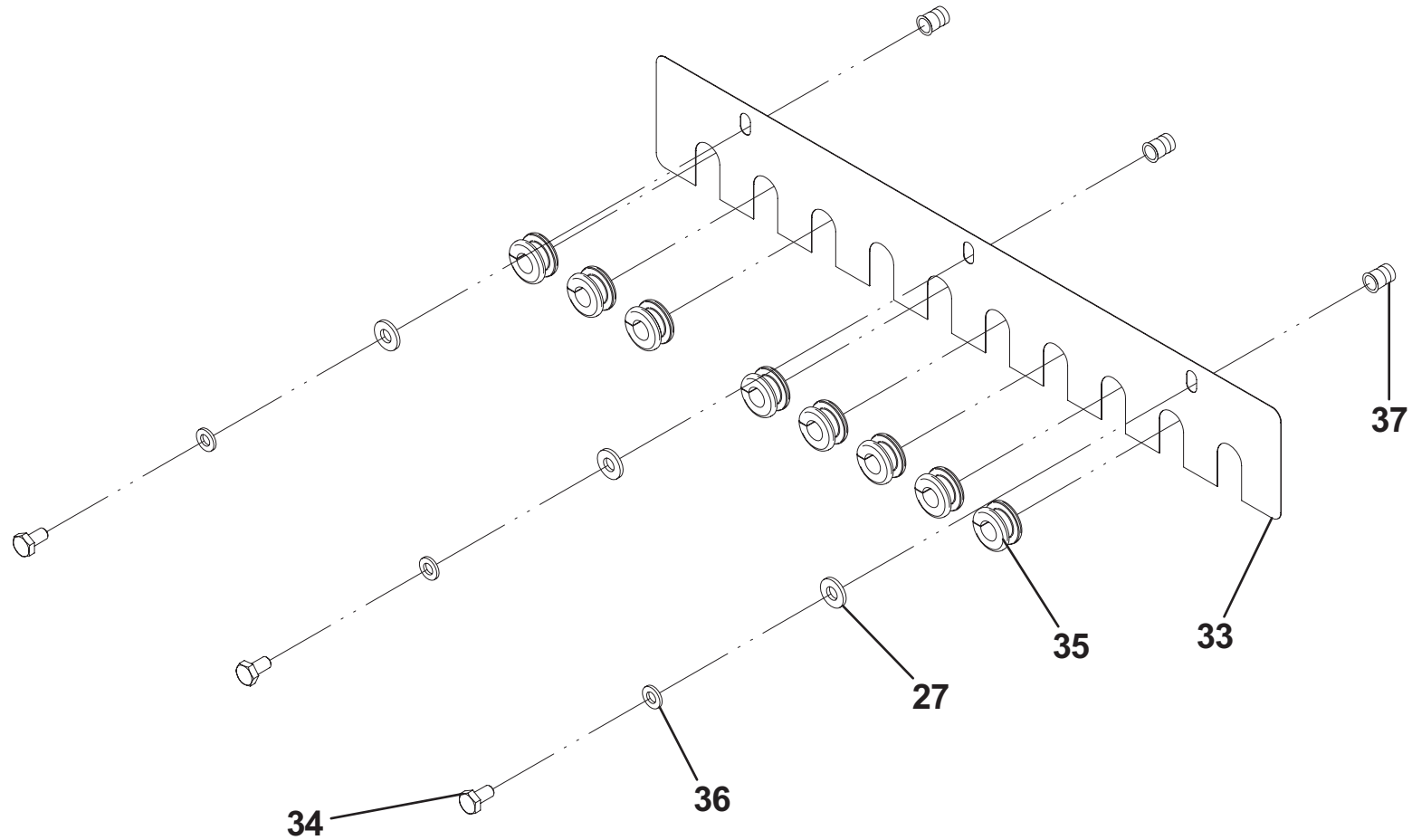

B

CONTROLS AND VALVE ASSEMBLY

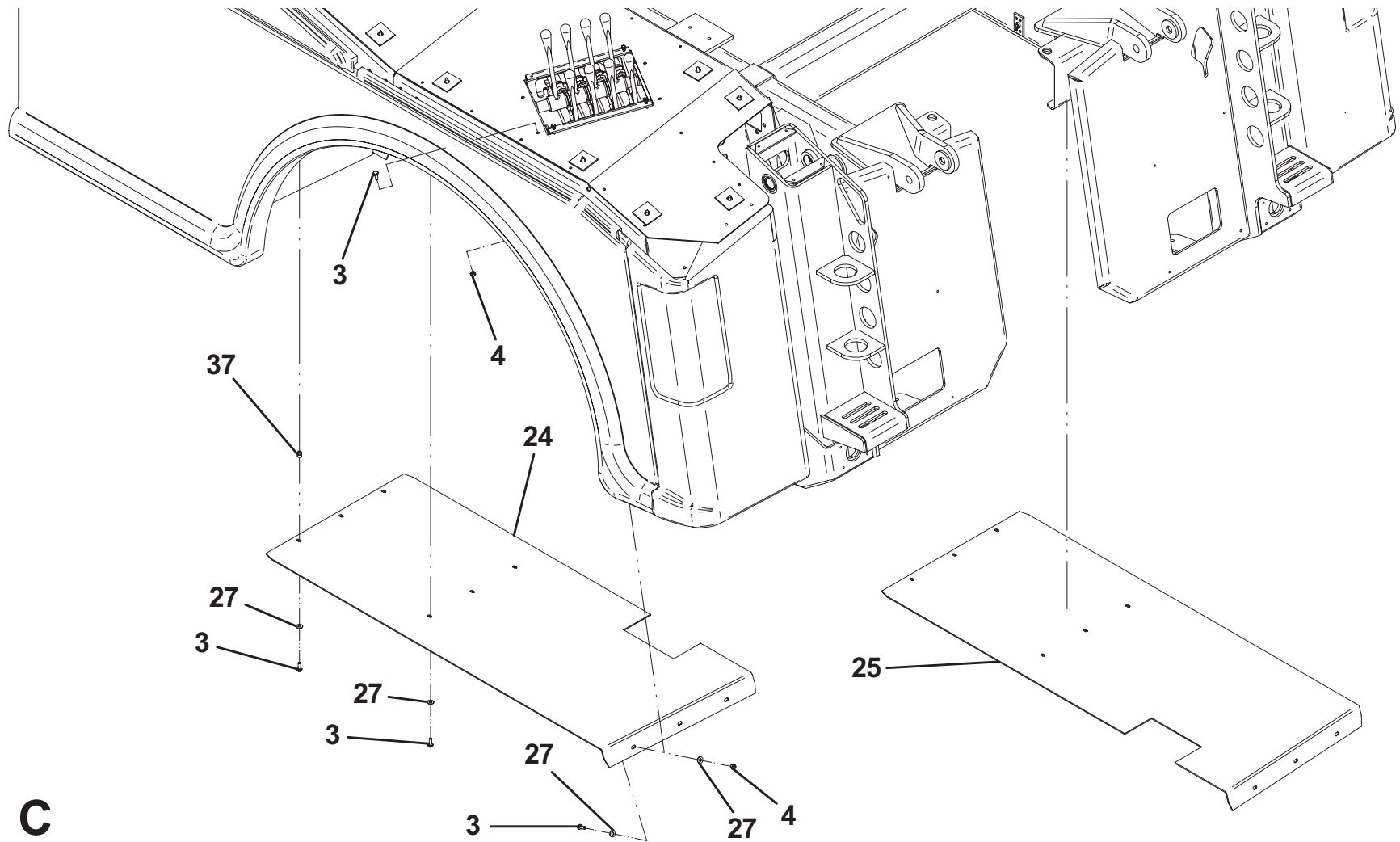

CONTROLS AND VALVE ASSEMBLY

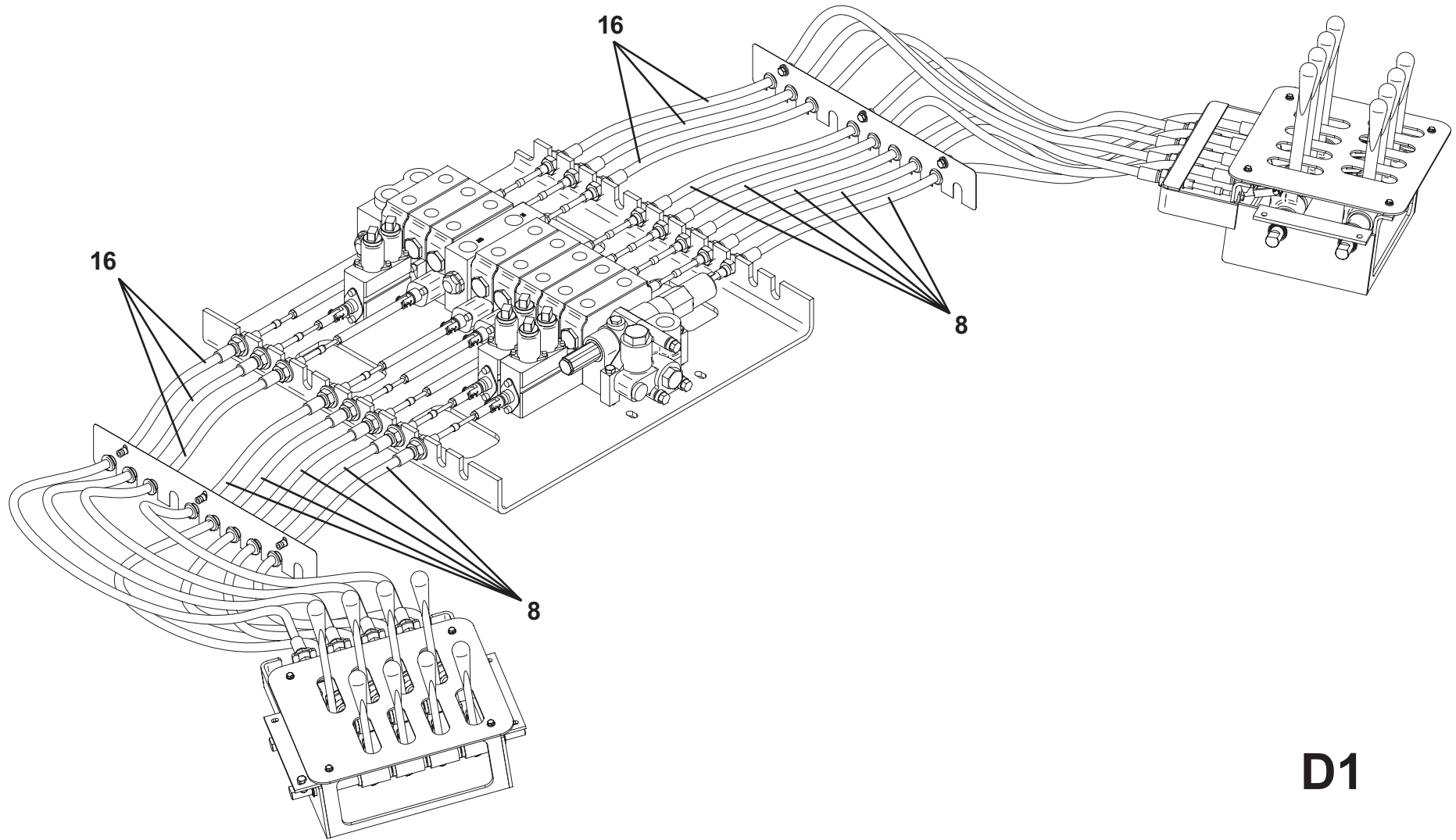

D1

CONTROLS AND VALVE ASSEMBLY

D-LH

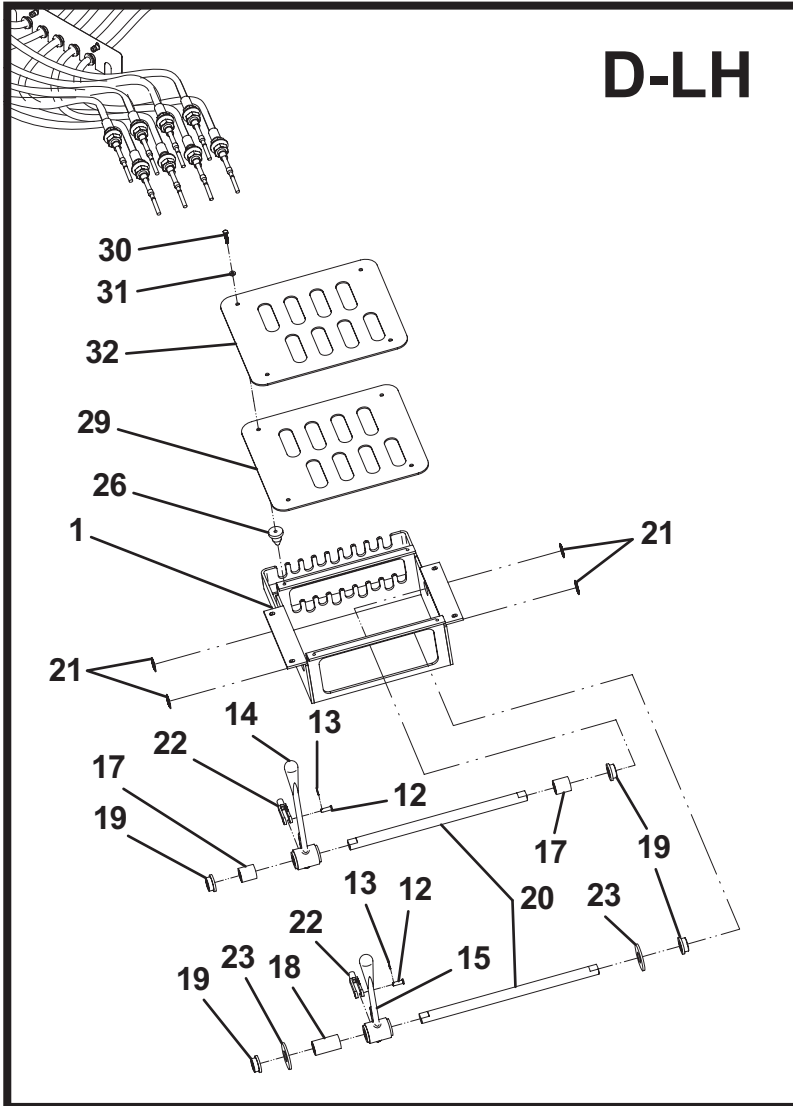

D-RH

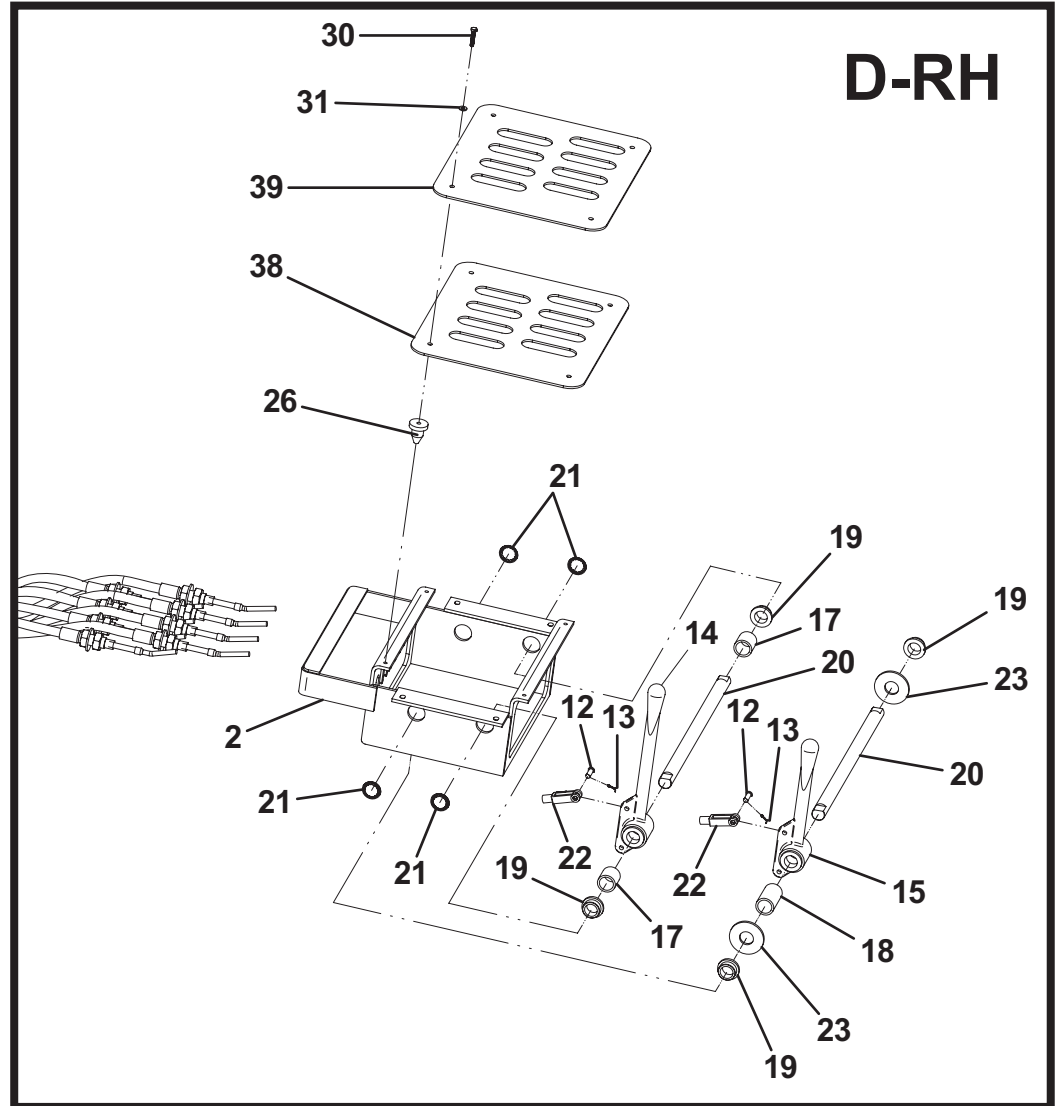

THIS PAGE INTENTIONALLY LEFT BLANK

VALVE ASSEMBLY - 7935000293

ITEM	PART NO.	DESCRIPTION	QTY
1	7935000315	Assembly, Inlet Cover	1
2	9935930122	Assembly, Work Section	2
3	9935930119	Assembly, Work Section	3
4	7935000320	Assembly, Work Section	3
5	7935000316	Mid-Inlet Section	1
6	7935000323	Utility Section	1
7	7935000317	Assembly, Outlet Cover	1
8	91084009	Valve, Relief	2
9	70050243	Plug, Load Check	4
10	91084010	Plug, Load Check	12
11	70050245	Plug, SAE #4	1
12	70050246	Plug, SAE #6	2
13	70050247	Plug, SAE #8	1
14	91084017	Plug, SAE #12	3
15	70050249	Plug, Gage	1
16	70050241	Valve, Pressure Relief	1
17	70050242	Valve, Pressure Relief	1
18	70050250	Seal, Spool	13
19	70050251	Seal, O-Ring	40
20	70050252	Seal, O-Ring	6
21	70050253	Kit, Seal	2
22	7029865	Kit, Seal	16
23	70050255	Kit, Seal	1
24	70050256	Kit, Seal	1
25	9346930086	Solenoid with Screw	6
26	70050240	Assembly, Section Seal	1
27	70050239	Assembly, Stud	1
28	70050257	Seal, Spool Wiper	16
29	70050260	Piston-V20-DSP	3
30	70050230	Bonnet	3

VALVE ASSEMBLY - 7935000293

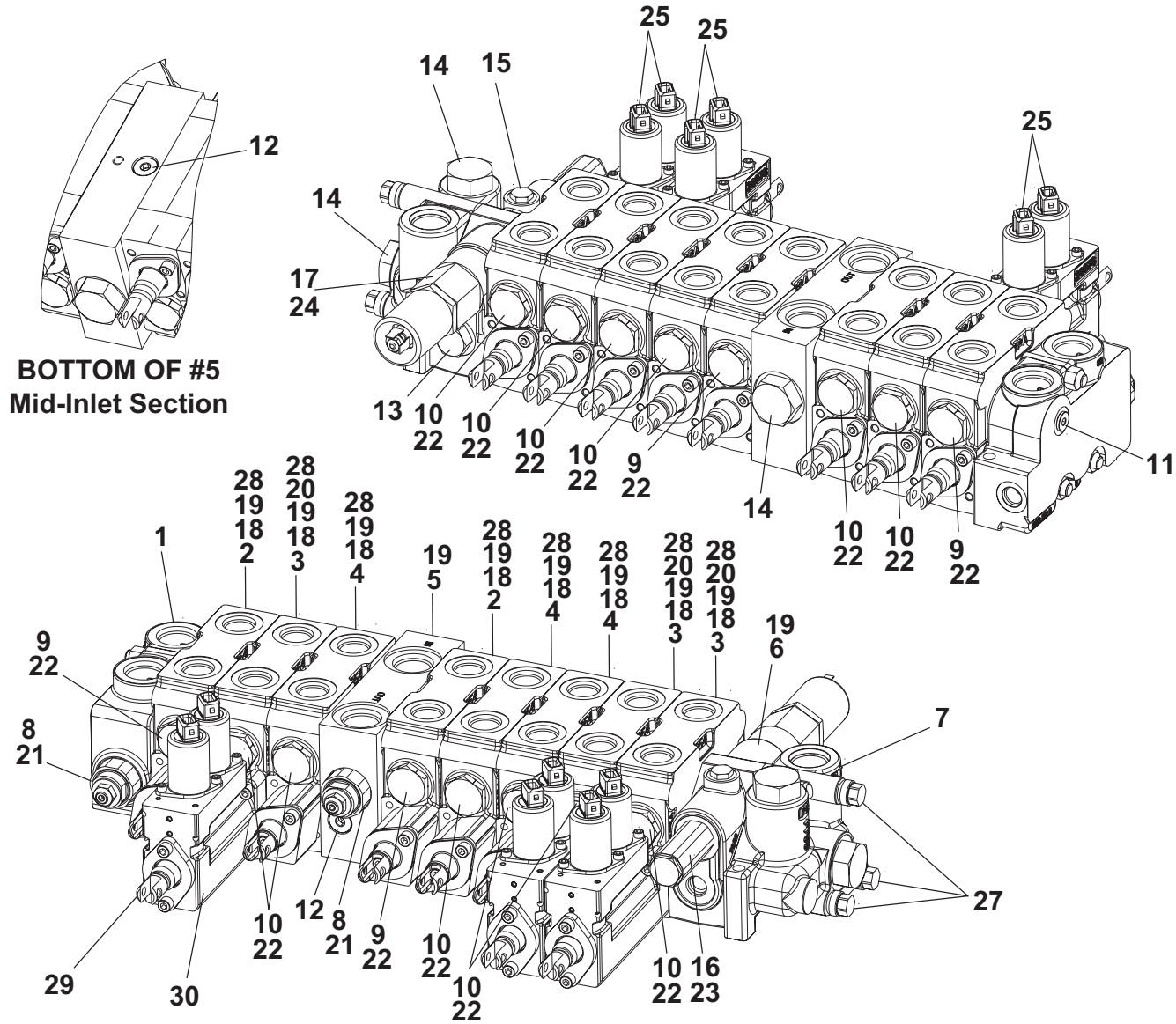

Item #26, not shown

SWITCH PANEL INSTALLATION 6 FUNCTION - 3870000005

ITEM	PART NO.	DESCRIPTION	QTY
1	7870000064	Switch Panel - 6 Function	1
2	7790141651	Screw, 0.25" x 1.00"	6
3	7950140141	Flatwasher, 0.25" ID	6
4	7493000003	Grommet	1
5	7346000039	Tubing, 0.25" Heat Shrink	24in
6	7345001914	Terminal	1

SWITCH PANEL INSTALLATION 6 FUNCTION - 3870000005

14	RED/WHITE	AUX 2 CIRCUIT
13	RED	POWER
12	ORANGE	BEACON #1 ROTATORS/FLASHERS
11	ORANGE/BLACK	BEACON #2 OSICILASERS
10	BLUE/BLK	FLOOD LIGHTS
9A	WHITE	GROUND, SWITCH PANEL
9	WHITE	GROUND
8	BLUE/WHITE	RIGHT TURN, FOREIGN
7	BLUE	WORK/HOOK-UP LIGHTS
6	WHITE/BLK	CABINET LIGHTING
5	BROWN	MARKER/TAIL
4	BLACK	BACK-UP
3	GREEN	RH STOP/TURN
2	YELLOW	LH STOP/TURN
1	PURPLE/WHITE	LEFT TURN, FOREIGN
CIRCUIT I.D.	COLOR	FUNCTION

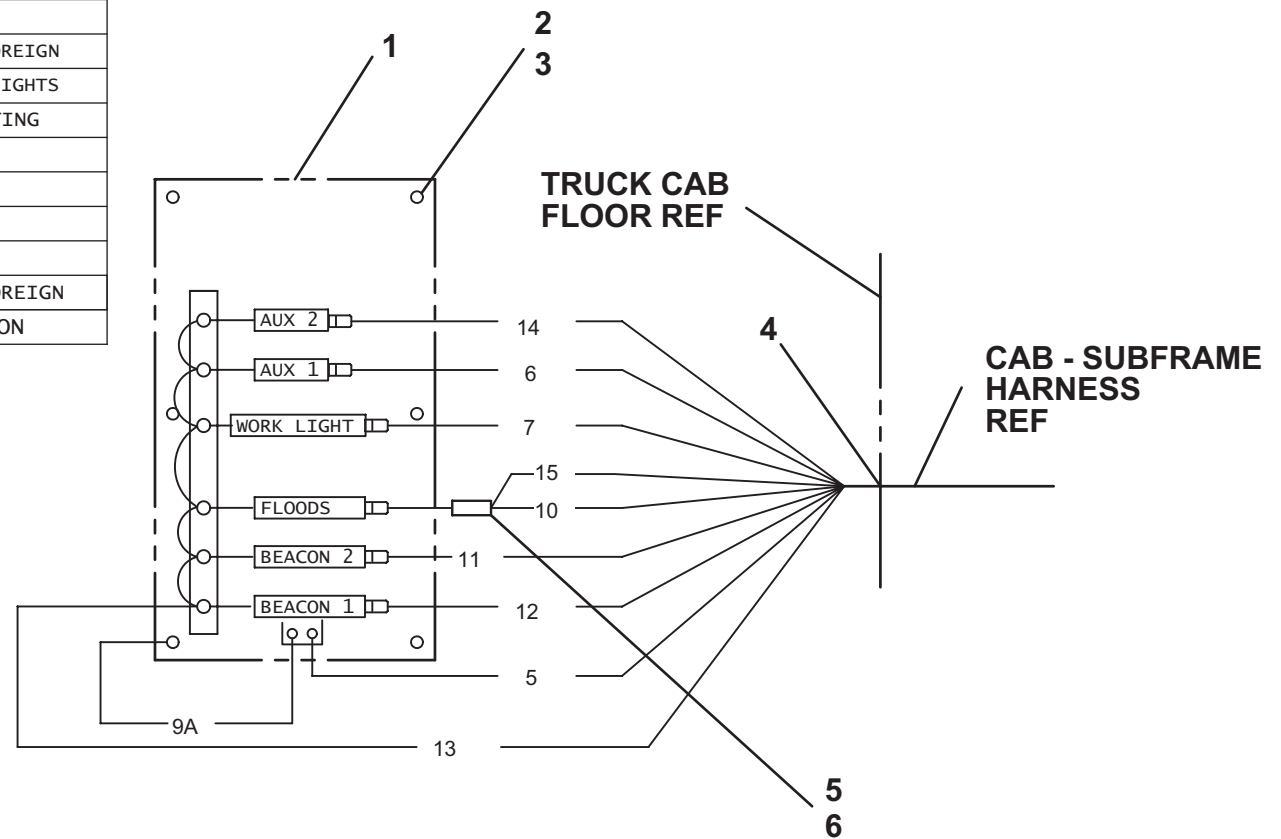

SWITCH PANEL INSTALLATION 6 FUNCTION, 3 UNDERLIFT - 3870000022

ITEM	PART NO.	DESCRIPTION	QTY
1	7870000068	Switch Panel	1
2	7790141651	Screw, 0.25" x 1.00"	6
3	7950140141	Flatwasher, 0.25" ID	6
4	7493000003	Grommet	2
5	7552000359	Harness	1
6	7345001914	Terminal	6
7	7345001714	Terminal	2
8	7346000039	Tubing, 0.25"	2
9	7345221702	Ring Terminal	2
10	7345001710	Tab Terminal	6

SWITCH PANEL INSTALLATION 6 FUNCTION, 3 UNDERLIFT - 387000022

14	RED/WHITE	AUX 2 CIRCUIT
13	RED	POWER
12	ORANGE	BEACON #1 ROTATORS/FLASHERS
11	ORANGE/BLACK	BEACON #2 OSCILASERS
10	BLUE/BLK	FLOOD LIGHTS
9A	WHITE	GROUND, SWITCH PANEL
9	WHITE	GROUND
8	BLUE/WHITE	RIGHT TURN, FOREIGN
7	BLUE	WORK/HOOK-UP LIGHTS
6	WHITE/BLK	CABINET LIGHTING
5	BROWN	MARKER/TAIL
4	BLACK	BACK-UP
3	GREEN	RH STOP/TURN
2	YELLOW	LH STOP/TURN
1	PURPLE/WHITE	LEFT TURN, FOREIGN
CIRCUIT I. D.		COLOR FUNCTION
HEADBOARD HARNESS		

FUNCTION	JD CIRCUIT	HARNESS COLOR
BOOM UP	1B	BLUE
TILT UP	2B	LT GREEN
WL BOOM OUT	3B	LT BLUE
BOOM DOWN	4B	BLUE/BLK
TILT DOWN	5B	LT GREEN/BLK
WL BOOM IN	6B	LT BLUE/BLK
PRESSURE	7B	BROWN/WHT

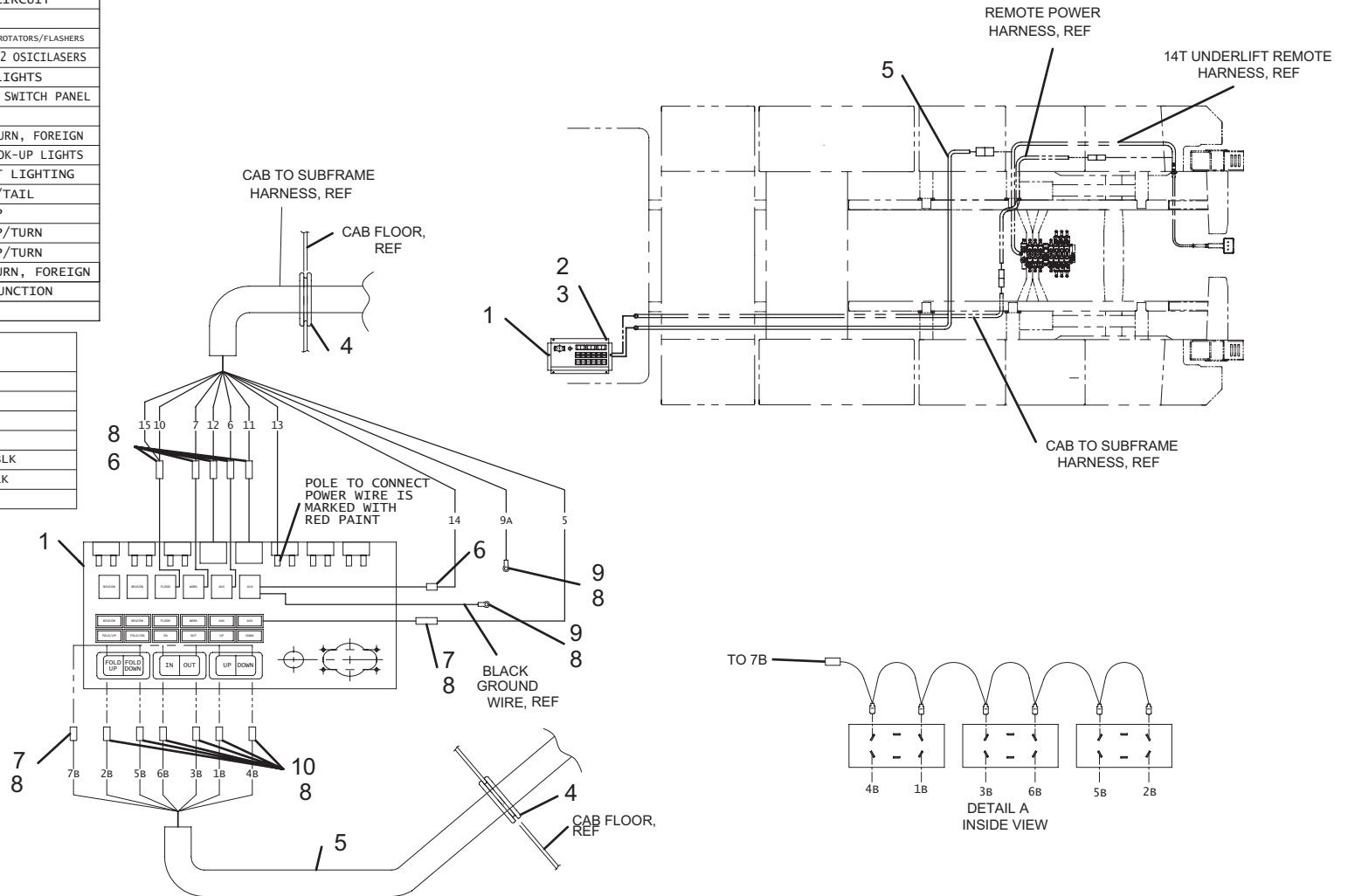

SWITCH PANEL INSTALLATION 9 FUNCTION - 3870000007

ITEM	PART NO.	DESCRIPTION	QTY
1	7870000075	Switch Panel	1
2	7790141651	Screw, 0.25" x 1.00"	6
3	7950140141	Flatwasher, 0.25" ID	6
4	7493000003	Grommet	2
5	7345001710	Terminal	4
6	7345001910	Terminal	2
7	7345001714	Terminal	3
8	7346000039	Tubing, 0.25"	24in

SWITCH PANEL INSTALLATION 9 FUNCTION- 387000007

14	RED/WHITE	AUX 2 CIRCUIT
13	RED	POWER
12	ORANGE	BEACON #1 ROTATORS/FLASHERS
11	ORANGE/BLACK	BEACON #2 OSICILASERS
10	BLUE/BLK	FLOOD LIGHTS
9A	WHITE	GROUND, SWITCH PANEL
9	WHITE	GROUND
8	BLUE/WHITE	RIGHT TURN, FOREIGN
7	BLUE	WORK/HOOK-UP LIGHTS
6	WHITE/BLK	CABINET LIGHTING
5	BROWN	MARKER/TAIL
4	BLACK	BACK-UP
3	GREEN	RH STOP/TURN
2	YELLOW	LH STOP/TURN
1	PURPLE/WHITE	LEFT TURN, FOREIGN
CIRCUIT I.D.	COLOR	FUNCTION
CAB TO SUBFRAME HARNESS		

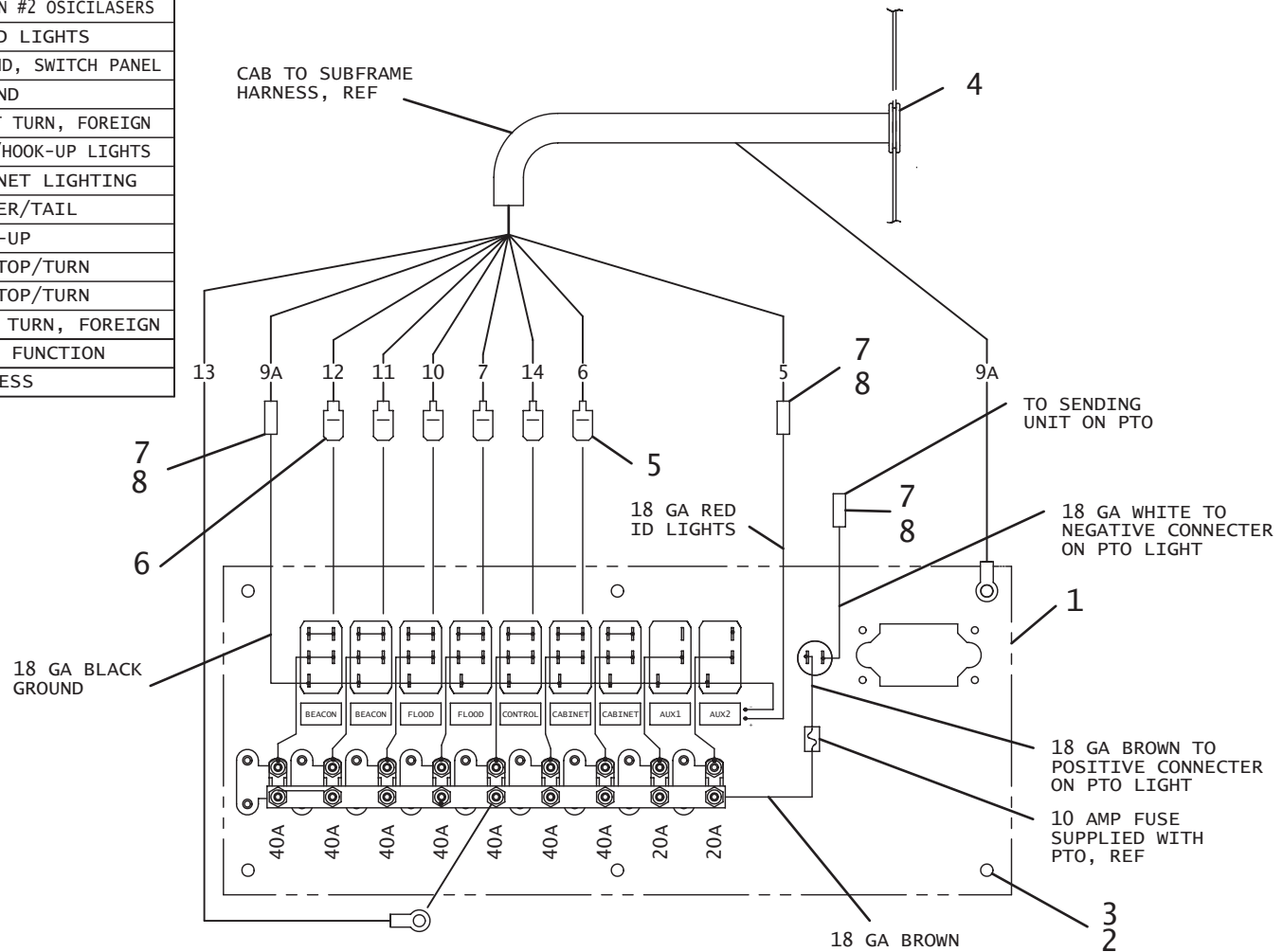

SWITCH PANEL INSTALLATION 9 FUNCTION, 3 UNDERLIFT - 3870000021

ITEM	PART NO.	DESCRIPTION	QTY
1	7870000058	Switch Panel	1
2	7493000003	Grommet	2
3	7790141651	Screw, 0.25" x 1.00"	4
4	7950140141	Flatwasher, 0.25" ID	4
5	7552000359	Harness	1
6	7345001710	Terminal	6
7	7346000039	Tubing, 0.25"	24in
8	7345001914	Terminal	9
9	7345001714	Terminal	1

SWITCH PANEL INSTALLATION 9 FUNCTION, 3 UNDERLIFT - 387000021

14	RED/WHITE	AUX 2 CIRCUIT
13	RED	POWER
12	ORANGE	BEACON #1 ROTATORS/FLASHERS
11	ORANGE/BLACK	BEACON #2 OSCILASERS
10	BLUE/BLK	FLOOD LIGHTS
9A	WHITE	GROUND, SWITCH PANEL
9	WHITE	GROUND
8	BLUE/WHITE	RIGHT TURN, FOREIGN
7	BLUE	WORK/HOOK-UP LIGHTS
6	WHITE/BLK	CABINET LIGHTING
5	BROWN	MARKER/TAIL
4	BLACK	BACK-UP
3	GREEN	RH STOP/TURN
2	YELLOW	LH STOP/TURN
1	PURPLE/WHITE	LEFT TURN, FOREIGN
CIRCUIT I.D. COLOR		FUNCTION
HEADBOARD HARNESS		

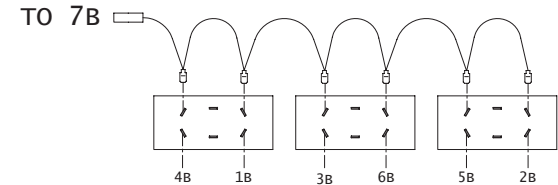
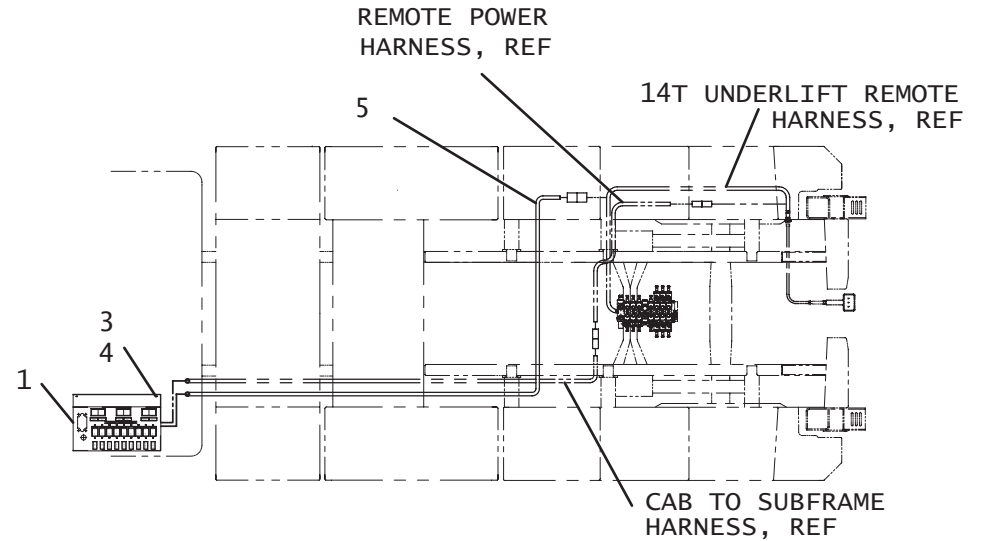
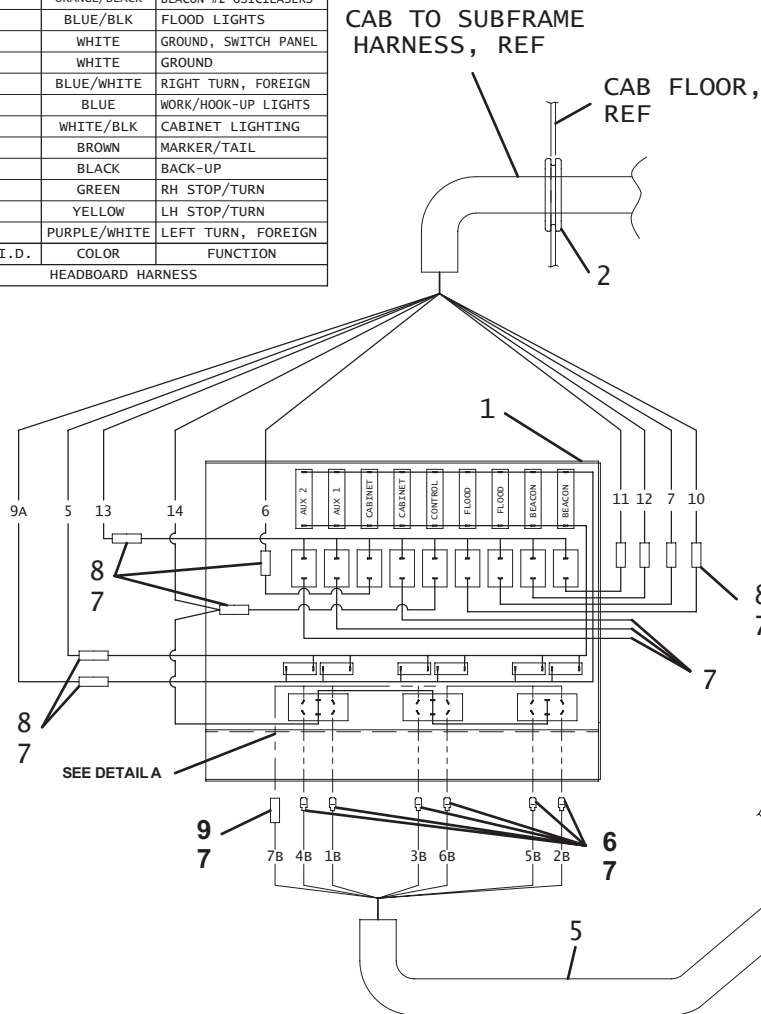

DETAIL A

FUNCTION	JD CIRCUIT	HARNES COLOR
BOOM UP	1B	BLUE
TILT UP	2B	LT GREEN
WL BOOM OUT	3B	LT BLUE
BOOM DOWN	4B	BLUE/BLK
TILT DOWN	5B	LT GREEN/BLK
WL BOOM IN	6B	LT BLUE/BLK
PRESSURE	7B	BROWN/WHT

SWITCH PANEL INSTALLATION 9 FUNCTION IN-DASH - 3870000009

ITEM	PART NO.	DESCRIPTION	QTY
1	7870000079	Switch Panel	1
2	7790080871	Screw, #8 x 0.50"	4
3	7493000003	Grommet	1
4	7345001713	Connector	2
5	7345221601	Terminal	2
6	4978000047	Wire, 16 Ga.	1
7	7345001710	Tab	1
8	7552000202	Harness	1
9	7346000039	Tubing	24"

SWITCH PANEL INSTALLATION 9 FUNCTION IN-DASH - 3870000009

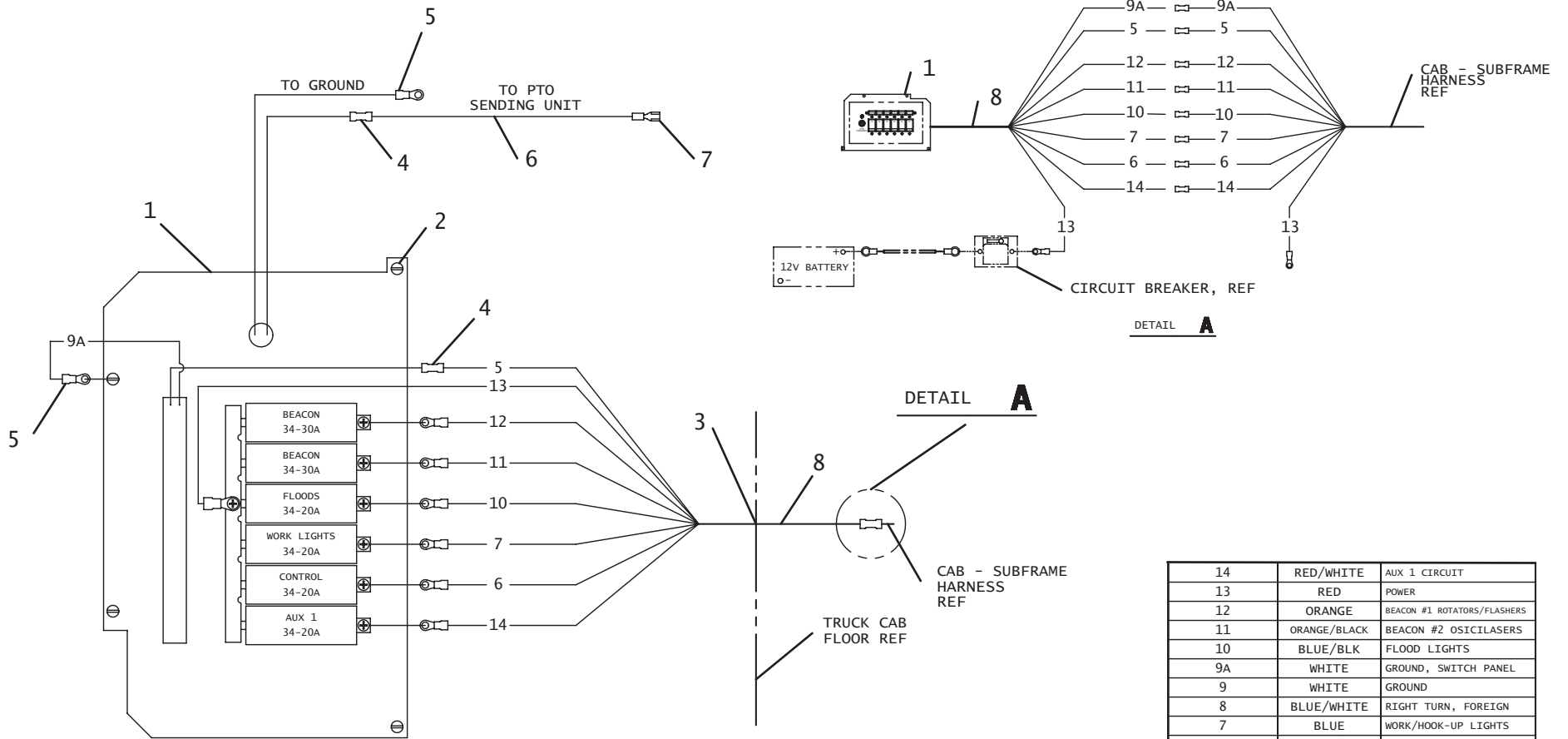

CIRCUIT I.D.	COLOR	FUNCTION
14	RED/WHITE	AUX 1 CIRCUIT
13	RED	POWER
12	ORANGE	BEACON #1 ROTATORS/FLASHERS
11	ORANGE/BLACK	BEACON #2 OSICILASERS
10	BLUE/BLK	FLOOD LIGHTS
9A	WHITE	GROUND, SWITCH PANEL
9	WHITE	GROUND
8	BLUE/WHITE	RIGHT TURN, FOREIGN
7	BLUE	WORK/HOOK-UP LIGHTS
6	WHITE/BLK	CONTROL
5	BROWN	MARKER/TAIL
4	BLACK	BACK-UP
3	GREEN	RH STOP/TURN
2	YELLOW	LH STOP/TURN
1	PURPLE/WHITE	LEFT TURN, FOREIGN
CIRCUIT I.D.	COLOR	FUNCTION

TRAILER TOWING PACKAGE

ITEM	PART NO.	DESCRIPTION	QTY
1	7312000015	Glad Hand	1
2	7312000016	Glad Hand	1
3	7446502518	Fitting, Bulkhead	2
4	7446382506	Connector, 0.38" Tube - 0.25" Male	4
5	7565000014	Airline Tubing 0.38" OD	50ft
6	7443000148	Bushing, 0.38" Male x 0.25" Female	2
7	7443000146	Elbow, 0.38" Male x 0.38" Female	2
8	7443000145	Bushing, 0.50" Male x 0.38" Female	2
9	7577000145	Seal Kit, Glad hands	1
10	7345000055	Electrical Receptacle, 7-way	1
11	7346000078	Electrical Boot, 7-way	1
12	7115150864	Bolt, 0.31"-18NC x 1.00"	2
13	7950150161	Flatwasher, 0.31" ID	2
14	7660152601	Locknut, 0.31"-18NC	2
15	7330000208	Decal, Service Air	1
16	7330000209	Decal, Supply Air	1

TRAILER TOWING PACKAGE

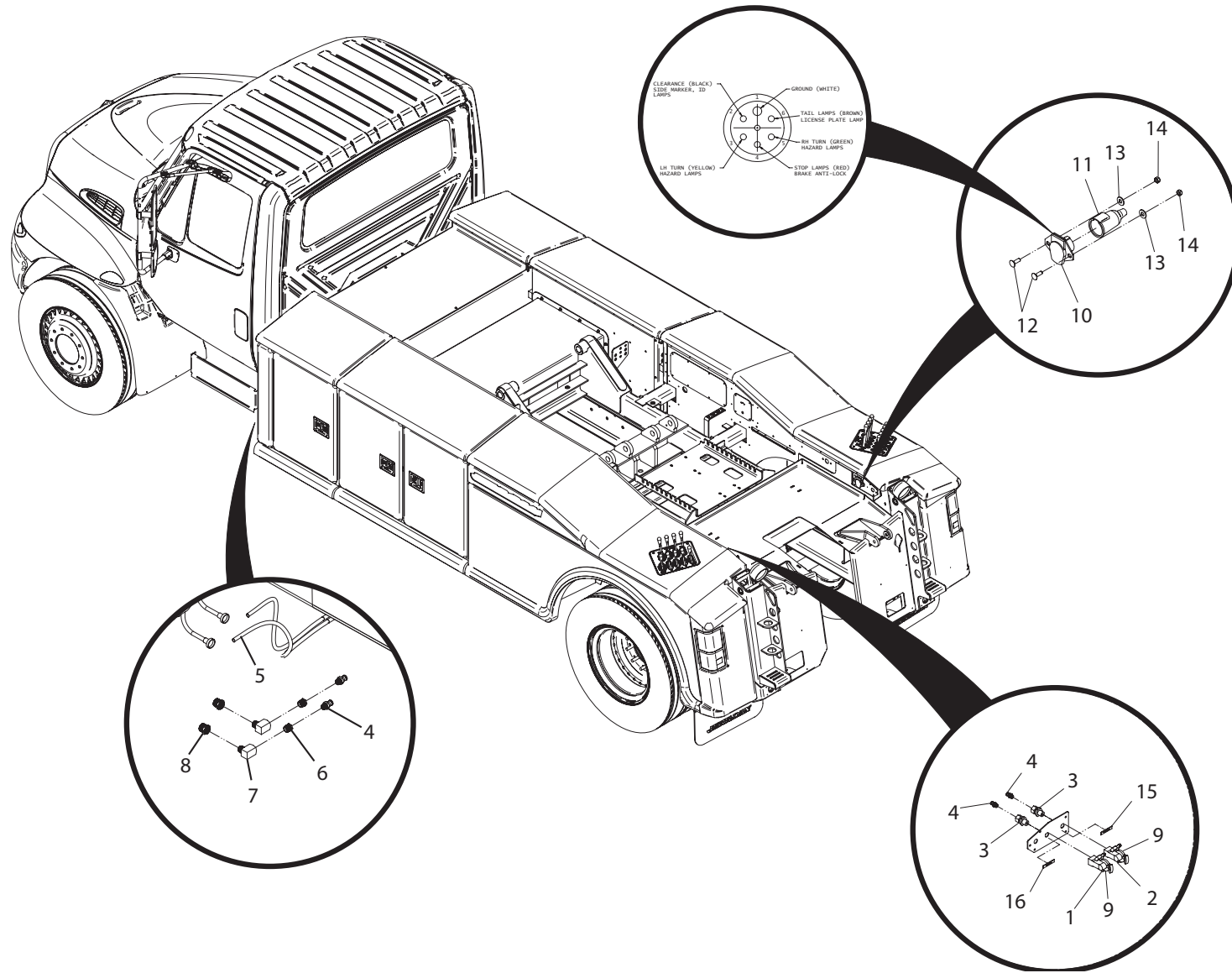

DECALS

ITEM	PART NO.	DESCRIPTION	QTY
1	7330000335	Decal, Lube Chart	1
2	1001132328	Decal, Serial Number Placard	1
3	7330000203	Decal, Power Line Warning	2
4	7330000199	Decal, Authorized Personnel	1
5	7330000200	Decal, Checklist	1
6	7330000253	Decal, Wire Rope Caution	1
7	7330000599	Decal, Pinch Point	1
8	7330000108	Decal, Jerr-Dan Logo	2
9	7330000034	Decal, Caution	1
10	7330000143	Decal, Made in the USA	1
11	7330000211	Decal, Safety Chain Warning	1
12	7330000122	Decal, Power Line Warning	2
13	1001132346	Patent Placard	1
14	7759000004	Pop Rivets	14
15	7330000262	Decal, Winch Warning	1
16	1001127220	Decal, Identification Tag	1
17	7330000337	Decal, Jerr-Dan Logo (Red)	1
	7330000528	Decal, Jerr-Dan Logo (White)	

DECALS

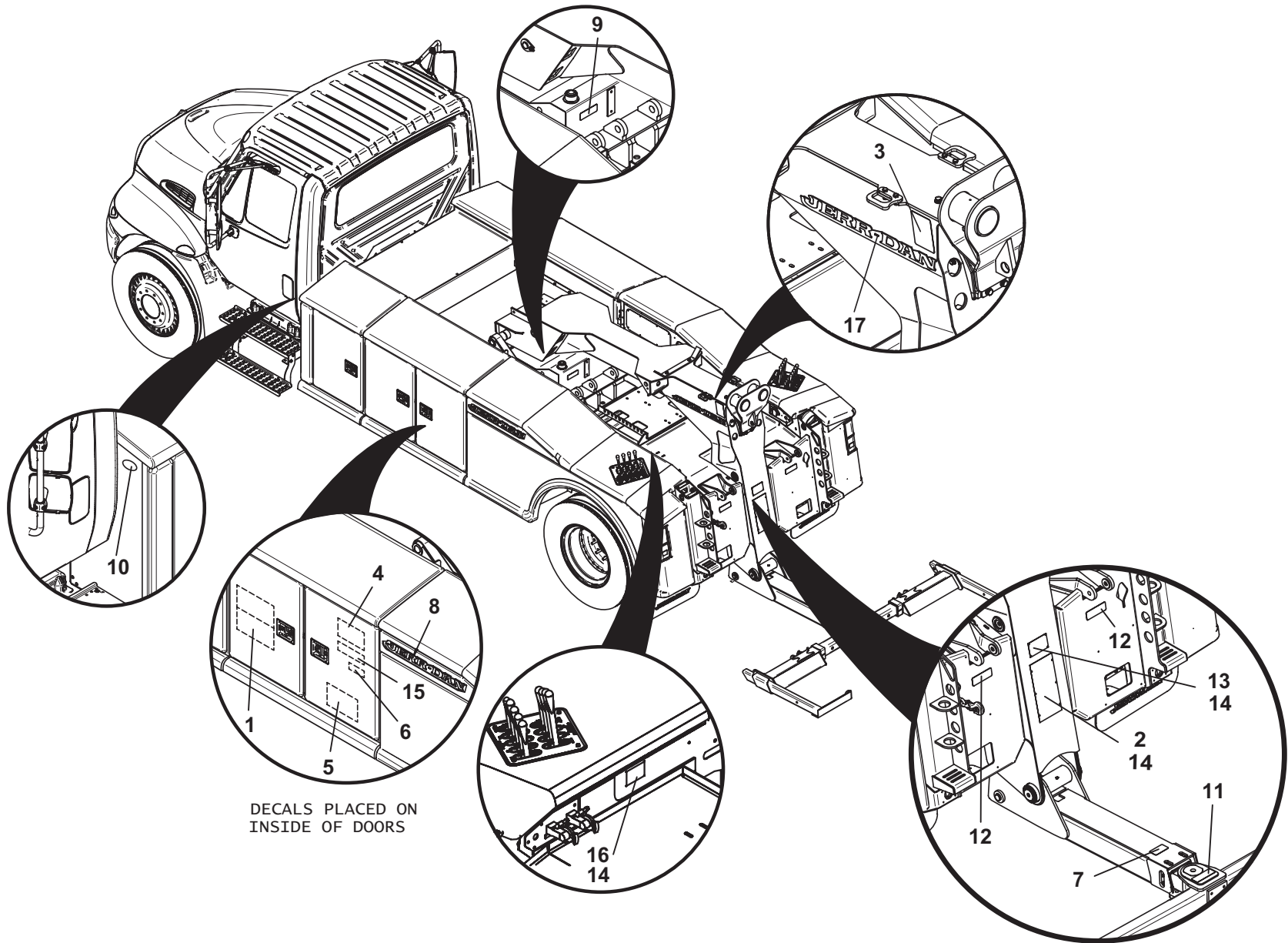

DECALS PLACED ON
INSIDE OF DOORS

THIS PAGE INTENTIONALLY LEFT BLANK



5376000161-0