

**STANDARD DUTY
LOW PROFILE CARRIER
PARTS MANUAL**

JERR-DAN[®]

An Oshkosh Corporation Company

13224 Fountainhead Plaza
Hagerstown, MD 21742
Phone (717) 597-7111
www.jerr-dan.com

5-376-000140
Rev 0 - August 01, 2010

© 2010 Jerr-Dan Corporation. All Rights Reserved.

This manual covers the following Jerr-Dan Models:

NGAF6T-LP	-	6 Ton Low Profile Aluminum Pioneer Fixed Rail	SRR6T-LP	-	6 Ton Low Profile Steel Removable Rail
NGADF6T-LP	-	6 Ton Low Profile Aluminum Pioneer Dual Angle Fixed Rail	SRRD6T-LP	-	6 Ton Low Profile Steel Shark
NGAR6T-LP	-	6 Ton Low Profile Aluminum Pioneer Removable Rail	STRB6T-LP	-	6 Ton Low Profile Steel B.I.C. Transporter
NGAT6T-LP	-	6 Ton Low Profile Aluminum Pioneer Transporter			

Jerr-Dan Corporation strives to provide information that is accurate, complete and useful. Descriptions and illustrative material contained within this manual are as accurate as known at the time of publication and are subject to change, without notice, as a result of continuous product improvements. Jerr-Dan reserves the right to amend the information in this document at any time without prior notice.

Information contained in this manual reflects how this vehicle was built at the factory. Modifications or additions by the distributor or owner are not reflected in this manual.

This parts manual does not include service parts information for the commercial chassis (IHC, Ford, GM, etc.). That information is provided by the chassis manufacturer.

When ordering parts, please refer to your unit's Serial Number and Model Number. This information is found on the aluminum tag riveted to the front left corner of the deck as shown below:

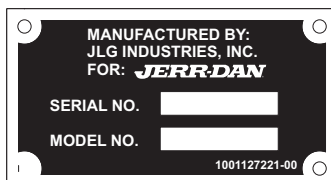

Additional or replacement manuals can be ordered by calling Jerr-Dan Parts at 717-597-7111. Price and availability will be quoted at time of the request.

Please report comments and/or errors by contacting Jerr-Dan Corporation's Technical Publications Department by e-mail at technicalpublications@jerr-dan.com or by FAX on 717-485-7162.

Manufactured under one or more of the following patents: 5,133,633; 5,575,606; 5,697,741; 5,951,235; 6,231,294 B1; 6,315,515 B1; 6,336,783 B1; 6,447,239 B2 and 7,264,305 B2 with other Patents Pending.

Jerr-Dan and the Jerr-Dan logo are registered trademarks and Run Hard is a service mark of Jerr-Dan Corporation, Greencastle, PA USA.

The material in this document is confidential and the property of Jerr-Dan Corporation. No part of this document may be photocopied, reproduced or translated to another language without the express written consent of Jerr-Dan Corporation.

THIS PAGE INTENTIONALLY LEFT BLANK

INDEX

DESCRIPTION	PAGE	DESCRIPTION	PAGE
Deck - 6 Ton Aluminum Fixed Rail Low Profile (NGAF6T-LP)	6 - 7	Manual L-Arm Wheel Lift Grid	100 - 101
Deck - 6 Ton Aluminum Dual Angle Fixed Rail Low Profile (NGADF6T-LP)	8 - 9	Manual T37 Pivoting Wheel Lift Grid	102 - 103
Deck - 6 Ton Aluminum Removable Rail Low Profile (NGAR6T-LP)	10 - 11	Hydraulic Rear Dock Stabilizer	104 - 105
Deck - 6 Ton Aluminum Transporter Low Profile (NGAT6T-LP)	12 - 13	Hydraulic Rear Dock Stabilizer w/ Reese Hitch Receiver	106 - 107
Deck - 6 Ton Steel Removable Rail Low Profile (SRR6T-LP)	14 - 15	Roll Cylinder Assembly	108 - 109
Deck - 6 Ton Steel Low Profile Shark (SRRD6T-LP)	16 - 17	Tilt Cylinder Assembly	110 - 111
Deck - 6 Ton Steel Transporter Low Profile (STRB6T-LP)	18 - 19	Wheel Lift Extend Cylinder Assembly	112 - 113
Adjustable Roll Cylinder Bracket - Deck	20 - 21	IRL/Stabilizer Cylinder Assembly.....	114 - 115
Standard Deck Mounted Headboard	22 - 23	Stabilizer Cylinder Assembly.....	116 - 117
Deluxe Deck Mounted Headboard	24 - 25	Lightbars	118 - 119
Bucket Rest Headboard	26 - 27	Switch Panels	120 - 121
Stationary Headboard	28 - 29	Work Lights	122 - 123
Worm Gear Winch	30 - 31	Bolt-On D-Rings	124 - 125
Worm Gear Winch Cable Roller Guide / Tensioner Plate	32 - 33	Remote Control Operation(s)	126 - 127
Manual Remote Free Spool - Deck Mounted Headboard	34 - 35	Remote Throttle Control	128 - 129
Manual Remote Free Spool - Stationary Headboard	36 - 37	Glad Hands and 7-Way Connector	130 - 131
Manual Remote Air Free Spool	38 - 39	Air Supply Disconnect	132 - 133
Subframe	40 - 41	Jump Start Kit	134 - 135
Hold Down	42 - 43	Folding Deck Ladder	136 - 137
Slide Pad	44 - 45	Chains and Straps	138 - 139
Mud Flap	46 - 47	Decals	140 - 141
Lightboxes	48 - 49	Accessory Equipment	142 - 143
Final Assembly	50 - 51	Hydraulic Schematic	144 - 148
Hydraulic Reservoir and Toolbox / Basket	52 - 57	Electrical Schematic	149
Toolbox	58 - 59		
Toolbox Shelf	60 - 61		
Toolbox Light	62 - 63		
Toolbox Top Stowage Tray and Marker Lights	64 - 65		
Dual Controls - 3 Bank	66 - 67		
Dual Controls - 4 Bank	68 - 69		
Dual Controls - 5 Bank	70 - 71		
Hydraulic Components - Standard	72 - 75		
Hydraulic Components - Standard (Hose Track)	76 - 77		
Hydraulic Components - Hose Routing / Mounting (Ford, GM & IHC)	78 - 79		
Hydraulic Components - IRL Wheel Lift with Manual Grids	80 - 81		
Hydraulic Components - Hydraulic Rear Dock Stabilizer	82 - 83		
Hydraulic Components - Stabilizer w/ Reese Hitch or Pintle Hitch Mtg Plate	84 - 85		
Electrical Components - Standard w/ Deck Mounted Headboard	86 - 87		
Electrical Components - Standard w/ Stationary Headboard	88 - 89		
Electrical Components - Optional (Tail Light Converter)	90 - 91		
Deck Marker Lights	92 - 93		
Headboard Side Marker Lights	94 - 95		
Additional Deck Marker Lights	96 - 97		
IRL Wheel Lift	98 - 99		

DECK - 6 TON ALUMINUM FIXED RAIL LOW PROFILE (NGAF6T-LP)

ITEM	PART NO.	DESCRIPTION	QTY
1	3097000675	21' Deck - 96" wide	1
	3097000676	21' Deck - 102" wide	
	3097000779	22' Deck - 96" wide	
	3097000780	22' Deck - 102" wide	
2	7679000017	Chain Tray Mat	2

DECK - 6 TON ALUMINUM FIXED RAIL LOW PROFILE (NGAF6T-LP)

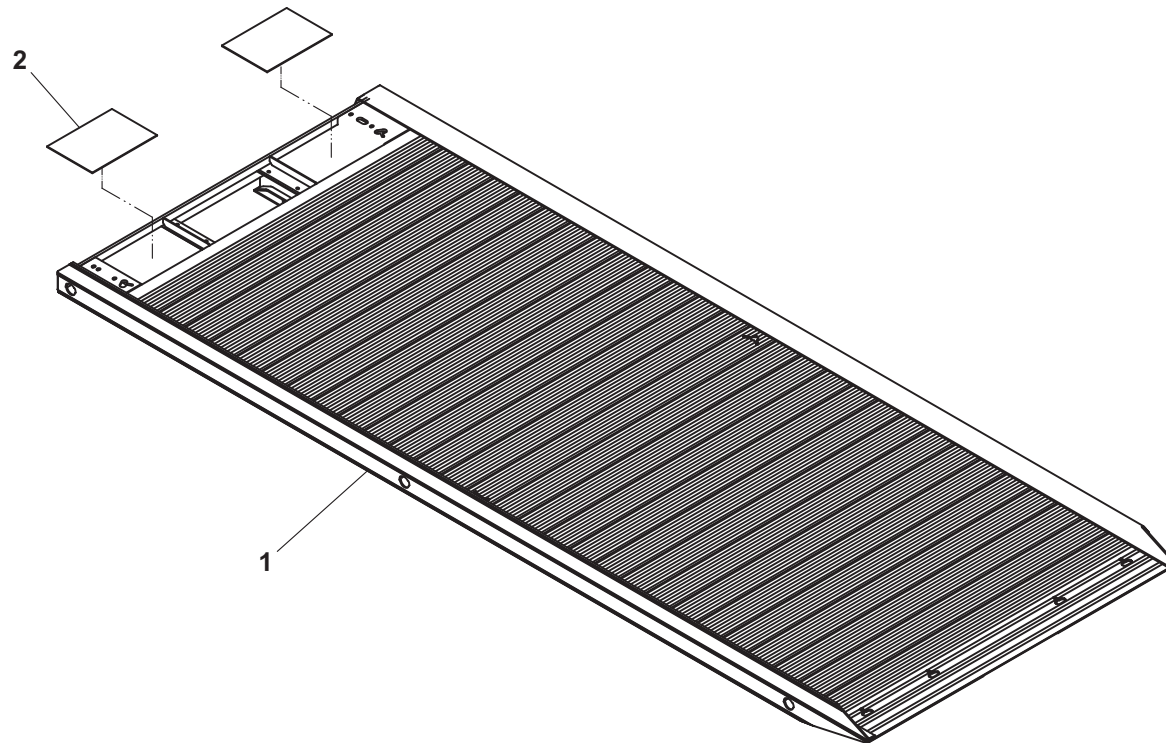

21' deck shown

DECK - 6 TON ALUMINUM DUAL ANGLE FIXED RAIL LOW PROFILE (NGADF6T-LP)

ITEM	PART NO.	DESCRIPTION	QTY
1	3097000681	21' Deck - 96" wide	1
	3097000682	21' Deck - 102" wide	
	3097000781	22' Deck - 96" wide	
	3097000782	22' Deck - 102" wide	
2	7679000017	Chain Tray Mat	2

DECK - 6 TON ALUMINUM DUAL ANGLE FIXED RAIL LOW PROFILE (NGADF6T-LP)

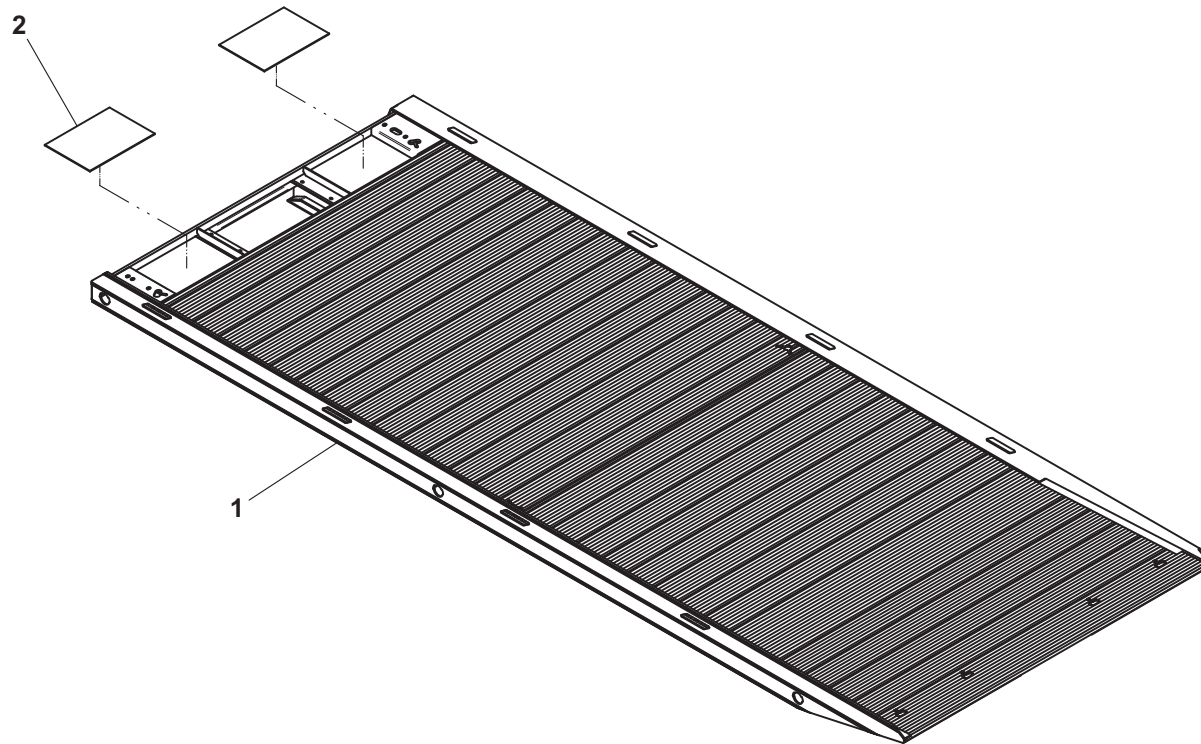

21' deck shown

DECK - 6 TON ALUMINUM REMOVABLE RAIL LOW PROFILE (NGAR6T-LP)

ITEM	PART NO.	DESCRIPTION	QTY	ITEM	PART NO.	DESCRIPTION	QTY
1	3097000673	21' Deck - 96" wide	1			<i>Standard Aluminum Removable Rails:</i>	
	3097000674	21' Deck - 102" wide					
	3097000777	22' Deck - 96" wide		10	3017000121	Angle Assembly LH Front	1
	3097000778	22' Deck - 102" wide		11	3017000122	Angle Assembly RH Front	1
2	7679000017	Chain Tray Mat	2	12	3017000129	Angle Assembly LH Rear (21' deck)	1
					3017000131	Angle Assembly LH Rear (22' deck)	
				13	3017000130	Angle Assembly RH Rear (21' deck)	1
					3017000132	Angle Assembly RH Rear (22' deck)	
				14	7120000005	Capscrew, 0.50"-13NC x 2.50"	10
						<i>Parts Breakdown of Angle Assemblies</i>	
				50	4017001699	Angle LH Front	1
				51	4017001700	Angle RH Front	
				52	4017001707	Angle LH Rear (21' deck)	1
					4017001709	Angle LH Rear (22' deck)	
				53	4017001708	Angle RH Rear (21' deck)	
					4017001710	Angle RH Rear (22' deck)	
				54	7115183664	Carriage Bolt, 0.50"-13NC x 4.50"	20
				55	8411080102	Extrusion	10
				56	4706006228	Plate	10
				57	7660182601	Locknut, 0.50"-13NC	20

DECK - 6 TON ALUMINUM REMOVABLE RAIL LOW PROFILE (NGAR6T-LP)

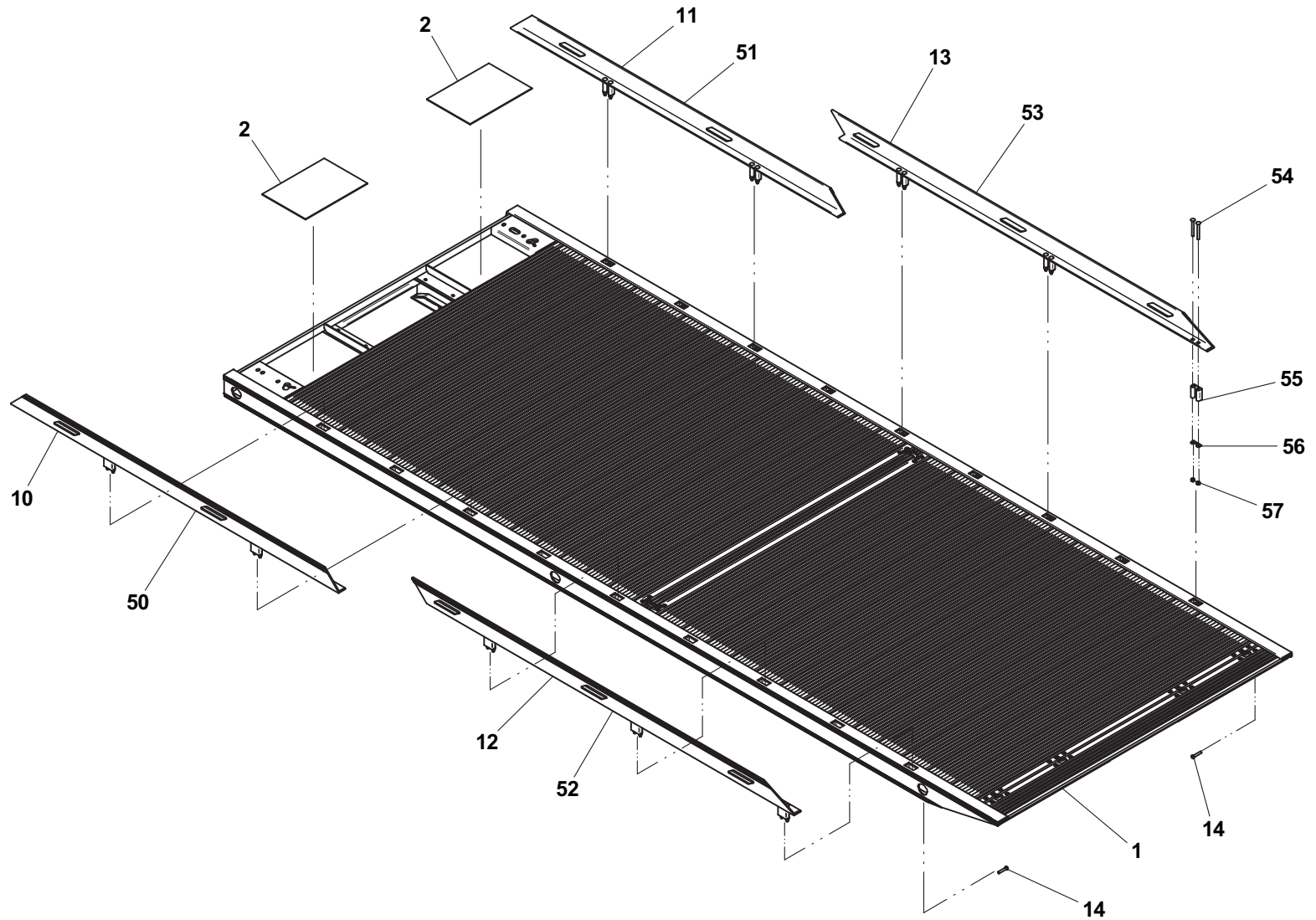

21' deck shown

DECK - 6 TON ALUMINUM TRANSPORTER LOW PROFILE (NGAT6T-LP)

ITEM	PART NO.	DESCRIPTION	QTY	ITEM	PART NO.	DESCRIPTION	QTY
1	3097000679	21' Deck - 95" wide	1			<i>Standard Aluminum Removable Rails:</i>	
	3097000680	21' Deck - 102" wide					
	3097000785	22' Deck - 95" wide		10	3017000121	Angle Assembly LH Front	1
	3097000786	22' Deck - 102" wide		11	3017000122	Angle Assembly RH Front	1
2	7679000017	Chain Tray Mat	2	12	3017000129	Angle Assembly LH Rear (21' deck)	1
3	Contact Parts	Keruing Board	A/R		3017000131	Angle Assembly LH Rear (22' deck)	
4	7786000007	Screw, 0.31"-18NC x 2.00"	A/R	13	3017000130	Angle Assembly RH Rear (21' deck)	1
					3017000132	Angle Assembly RH Rear (22' deck)	
				14	7120000005	Capscrew, 0.50"-13NC x 2.50"	10
						<i>Parts Breakdown of Angle Assemblies</i>	
				50	4017001699	Angle LH Front	1
				51	4017001700	Angle RH Front	
				52	4017001707	Angle LH Rear (21' deck)	1
					4017001709	Angle LH Rear (22' deck)	
				53	4017001708	Angle RH Rear (21' deck)	
					4017001710	Angle RH Rear (22' deck)	
				54	7115183664	Carriage Bolt, 0.50"-13NC x 4.50"	20
				55	8411080102	Extrusion	10
				56	4706006228	Plate	10
				57	7660182601	Locknut, 0.50"-13NC	20

DECK - 6 TON ALUMINUM TRANSPORTER LOW PROFILE (NGAT6T-LP)

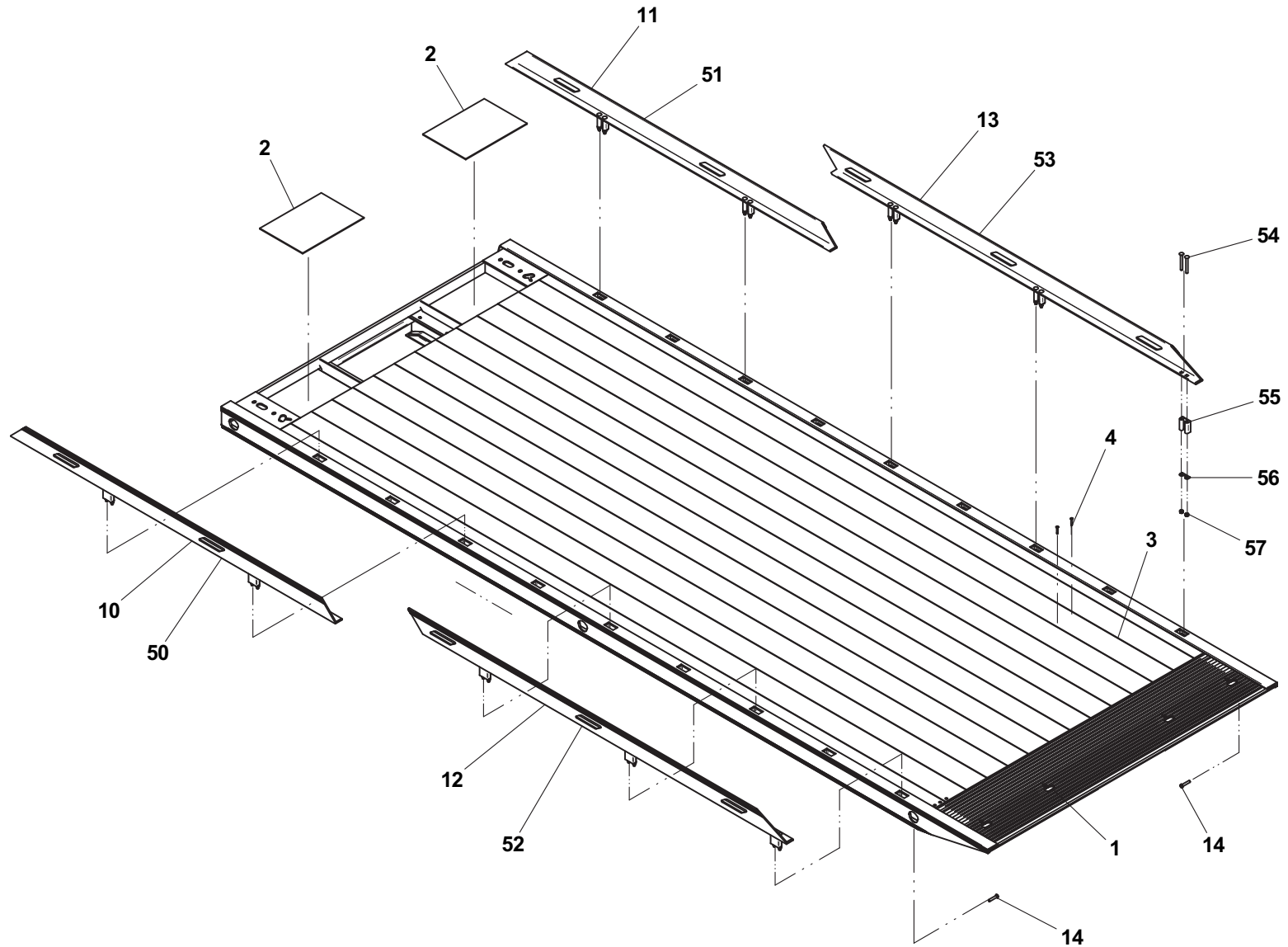

21' deck shown

DECK - 6 TON STEEL REMOVABLE RAIL LOW PROFILE (SRR6T-LP)

ITEM	PART NO.	DESCRIPTION	QTY	ITEM	PART NO.	DESCRIPTION	QTY
1	3097000745	21' Deck - 95" wide	1			<i>Standard Steel Tubular Removable Rails:</i>	
	3097000649	21' Deck - 102" wide					
	3097000773	22' Deck - 95" wide		10	3729000282	Rail Weldment Front	2
	3097000774	22' Deck - 102" wide		11	3729000283	Rail Weldment Rear	2
				12	7115181050	Capscrew, 0.50"-13NC x 1.25"	10
				13	7701000033	End Cap	4
						<i>Optional Aluminum Removable Rails:</i>	
				20	3017000121	Angle Assembly LH Front	1
				21	3017000122	Angle Assembly RH Front	1
				22	3017000129	Angle Assembly LH Rear (21' deck)	1
					3017000131	Angle Assembly LH Rear (22' deck)	
				23	3017000130	Angle Assembly RH Rear (21' deck)	1
					3017000132	Angle Assembly RH Rear (22' deck)	
				24	7120000005	Capscrew, 0.50"-13NC x 2.50"	10
						<i>Parts Breakdown of Angle Assemblies</i>	
				50	4017001699	Angle LH Front	1
				51	4017001700	Angle RH Front	
				52	4017001707	Angle LH Rear (21' deck)	1
					4017001709	Angle LH Rear (22' deck)	
				53	4017001708	Angle RH Rear (21' deck)	
					4017001710	Angle RH Rear (22' deck)	
				54	7115183664	Carriage Bolt, 0.50"-13NC x 4.50"	20
				55	8411080102	Extrusion	10
				56	4706006228	Plate	10
				57	7660182601	Locknut, 0.50"-13NC	20

DECK - 6 TON STEEL REMOVABLE RAIL LOW PROFILE (SRR6T-LP)

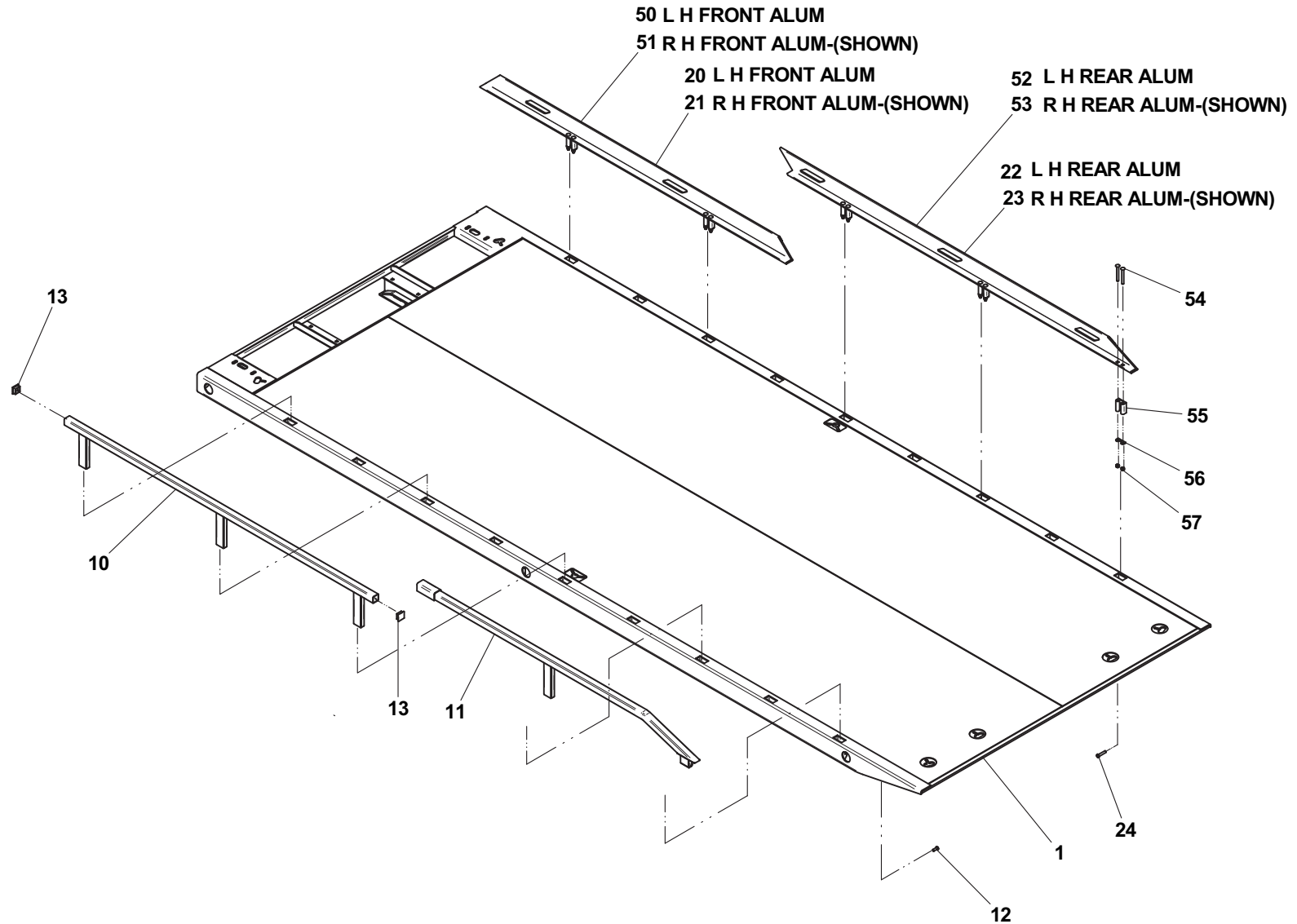

21' deck shown with standard removable steel rails on left side and optional aluminum removable rails on right side

DECK - 6 TON STEEL LOW PROFILE SHARK (SRRD6T-LP)

ITEM	PART NO.	DESCRIPTION	QTY	ITEM	PART NO.	DESCRIPTION	QTY
1	3097000751	21' Deck - 95" wide	1				
	3097000723	21' Deck - 102" wide					
	3097000775	22' Deck - 95" wide					
	3097000776	22' Deck - 102" wide					
2	3017000139	Angle Assembly LH (21' deck)	1				
	3017000142	Angle Assembly LH (22' deck)					
3	3017000140	Angle Assembly RH (21' deck)	1				
	3017000143	Angle Assembly RH (22' deck)					
4	7120000005	Capscrew, 0.50"-13NC x 2.50"	10				
		<i>Parts Breakdown of Angle Assemblies</i>					
50	4017001717	Angle LH (21' deck)	1				
	4017001740	Angle LH (22' deck)					
51	4017001718	Angle RH (21' deck)	1				
	4017001741	Angle RH (22' deck)					
52	7115183664	Carriage Bolt, 0.50"-13NC x 4.50"	20				
53	8411080102	Extrusion	10				
54	4706006228	Plate	10				
	7660182601	Locknut, 0.50"-13NC	20				

DECK - 6 TON STEEL LOW PROFILE SHARK (SRRD6T-LP)

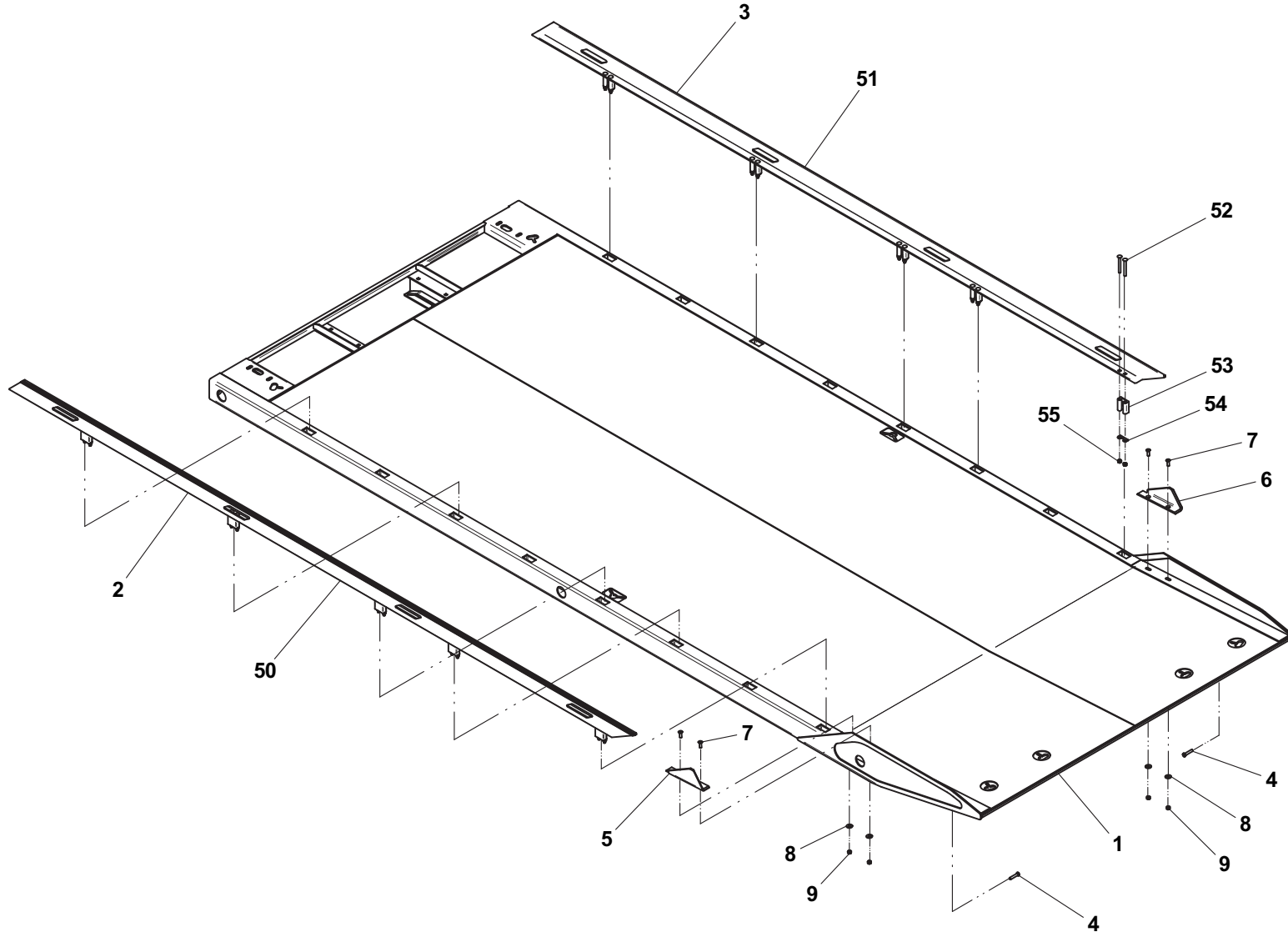

21' deck shown

DECK - 6 TON STEEL TRANSPORTER LOW PROFILE (STRB6T-LP)

ITEM	PART NO.	DESCRIPTION	QTY	ITEM	PART NO.	DESCRIPTION	QTY
1	3097000728	21' Deck - 95" wide	1			<i>Standard Steel Tubular Removable Rails:</i>	
	3097000729	21' Deck - 102" wide					
	3097000783	22' Deck - 95" wide		10	3729000282	Rail Weldment Front (21' & 22' decks)	2
	3097000784	22' Deck - 102" wide		11	3729000283	Rail Weldment Rear (21' & 22' decks)	2
2	Contact Parts	Keruing Board	A/R	12	7115181050	Capscrew, 0.50"-13NC x 1.25"	10
3	7786000007	Screw, 0.31"-18NC x 2.00"	A/R	13	7701000033	End Cap	4
						<i>Optional Aluminum Removable Rails:</i>	
				20	3017000121	Angle Assembly LH Front	1
				21	3017000122	Angle Assembly RH Front	1
				22	3017000129	Angle Assembly LH Rear (21' deck)	1
					3017000131	Angle Assembly LH Rear (22' deck)	
				23	3017000130	Angle Assembly RH Rear (21' deck)	1
					3017000132	Angle Assembly RH Rear (22' deck)	
				24	7120000005	Capscrew, 0.50"-13NC x 2.50"	10
						<i>Parts Breakdown of Angle Assemblies</i>	
				50	4017001699	Angle LH Front	1
				51	4017001700	Angle RH Front	
				52	4017001707	Angle LH Rear (21' deck)	1
					4017001709	Angle LH Rear (22' deck)	
				53	4017001708	Angle RH Rear (21' deck)	
					4017001710	Angle RH Rear (22' deck)	
				54	7115183664	Carriage Bolt, 0.50"-13NC x 4.50"	20
				55	8411080102	Extrusion	10
				56	4706006228	Plate	10
				57	7660182601	Locknut, 0.50"-13NC	20

DECK - 6 TON STEEL TRANSPORTER LOW PROFILE (STRB6T-LP)

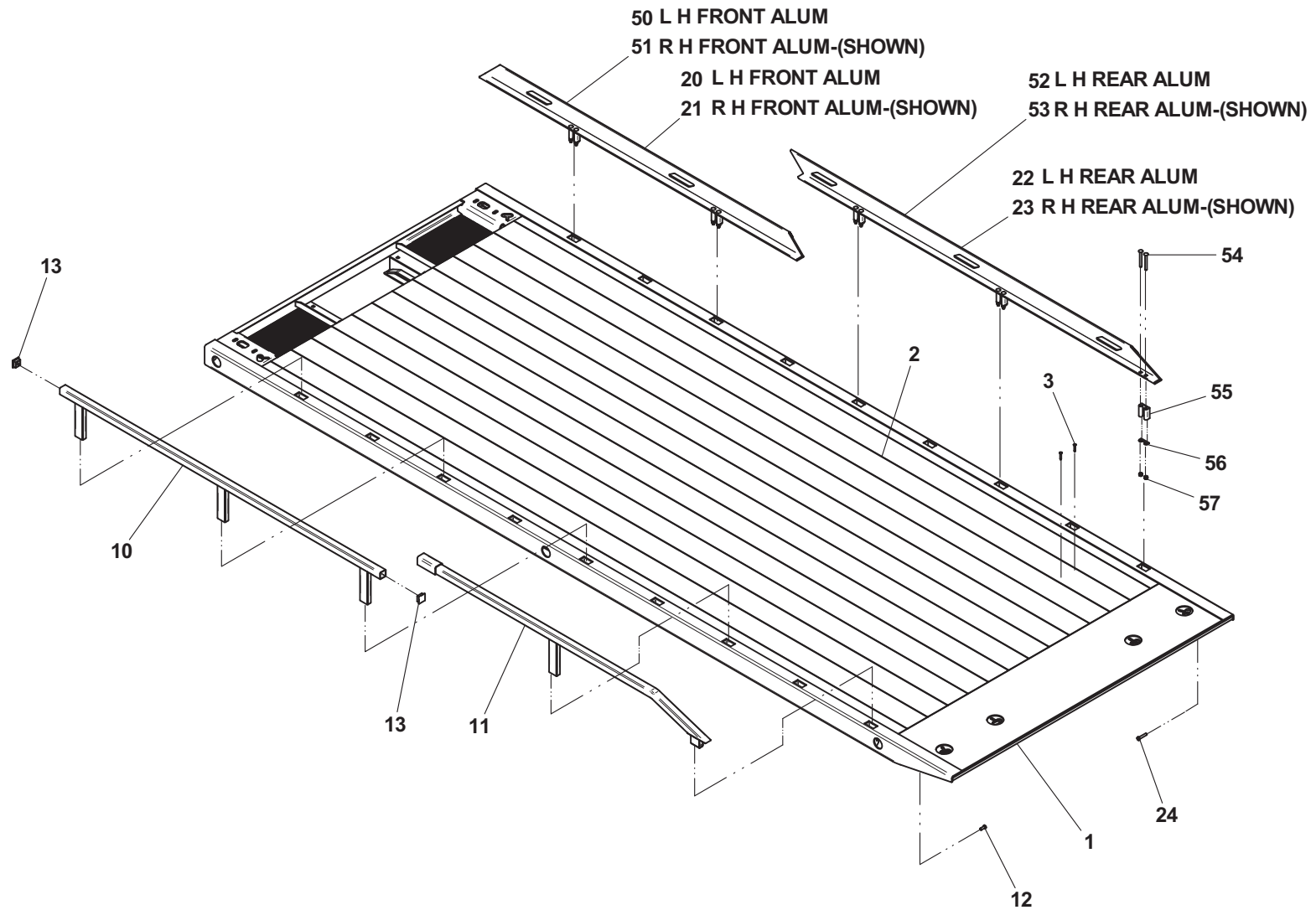

21' deck shown with optional removable steel rails on left side and optional aluminum removable rails on right side

ADJUSTABLE ROLL CYLINDER BRACKET - DECK

ITEM	PART NO.	DESCRIPTION	QTY
1	3017000104	Roll Cylinder Angle	1
2	7115221650	Capscrew, 0.75"-10NC x 2.00"	4
3	7660222601	Nut, 0.75"-10NC, Nyloc	4

ADJUSTABLE ROLL CYLINDER BRACKET - DECK

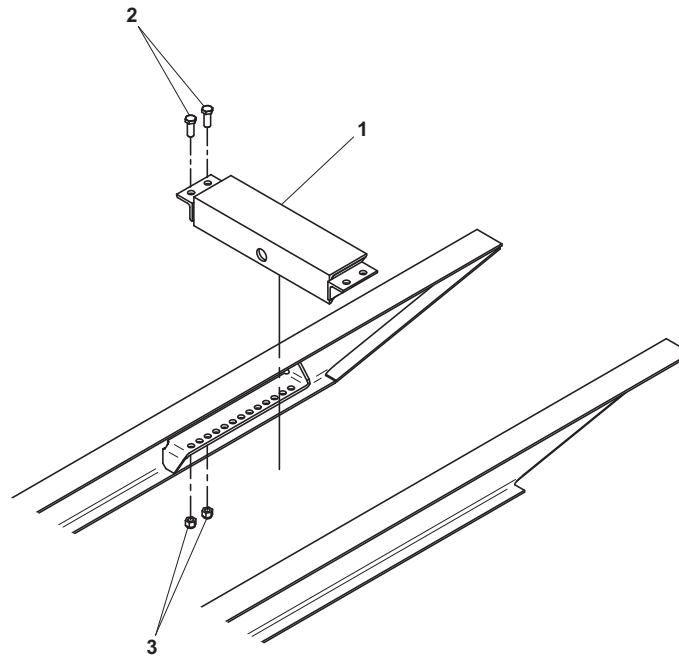

STANDARD DECK MOUNTED HEADBOARD

ITEM	PART NO.	DESCRIPTION	QTY	ITEM	PART NO.	DESCRIPTION	QTY
1	1001129136	Standard Headboard Weld - 36.50" Black Paint (w/ std remote free spool)	1	6	4686000295*	Panel (36.50" or 45.50" headboard w/ std remote free spool)	1
	1001129137	Standard Headboard Weld - 36.50" Silver Paint (w/ std remote free spool)			4686000296*	Panel (50.50" or 57.50" headboard w/std remote free spool)	
	1001129138	Standard Headboard Weld - 45.50" Black Paint (w/ std remote free spool)			4686000301*	Panel (45.50" headboard w/ air remote free spool)	
	1001129139	Standard Headboard Weld - 45.50" Silver Paint (w/ std remote free spool)			4686000302*	Panel (50.50" or 57.50" headboard w/ air remote free spool)	
	1001129144	Standard Headboard Weld - 45.50" Black Paint (w/ air remote free spool)		7	4892000008*	Tape (36.50" or 45.50" headboard)	4
	1001129145	Standard Headboard Weld - 45.50" Silver Paint (w/ air remote free spool)		8	7759000022*	Pop Rivet	8
	1001129140	Standard Headboard Weld - 50.50" Black Paint (w/ std remote free spool)					
	1001129141	Standard Headboard Weld - 50.50" Silver Paint (w/ std remote free spool)					
	1001129146	Standard Headboard Weld - 50.50" Black Paint (w/ air remote free spool)					
	1001129148	Standard Headboard Weld - 50.50" Silver Paint (w/ air remote free spool)					
	1001129142	Standard Headboard Weld - 57.50" Black paint (w/ std remote free spool)					
	1001129143	Standard Headboard Weld - 57.50" Black paint (w/ std remote free spool)					
	1001129149	Standard Headboard Weld - 57.50" Black Paint (w/ air remote free spool)					
	1001129150	Standard Headboard Weld - 57.50" Silver Paint (w/ air remote free spool)					
2	4796000037	Gasket	2				
3	7105201650	Capscrew, 0.63"-18NF x 2.00"	4				
4	7950200152	Flatwasher, 0.63" ID	4				
5	7660200035	Nut, 0.63"-18NF	2				

* included with Standard Headboard Weld

STANDARD DECK MOUNTED HEADBOARD

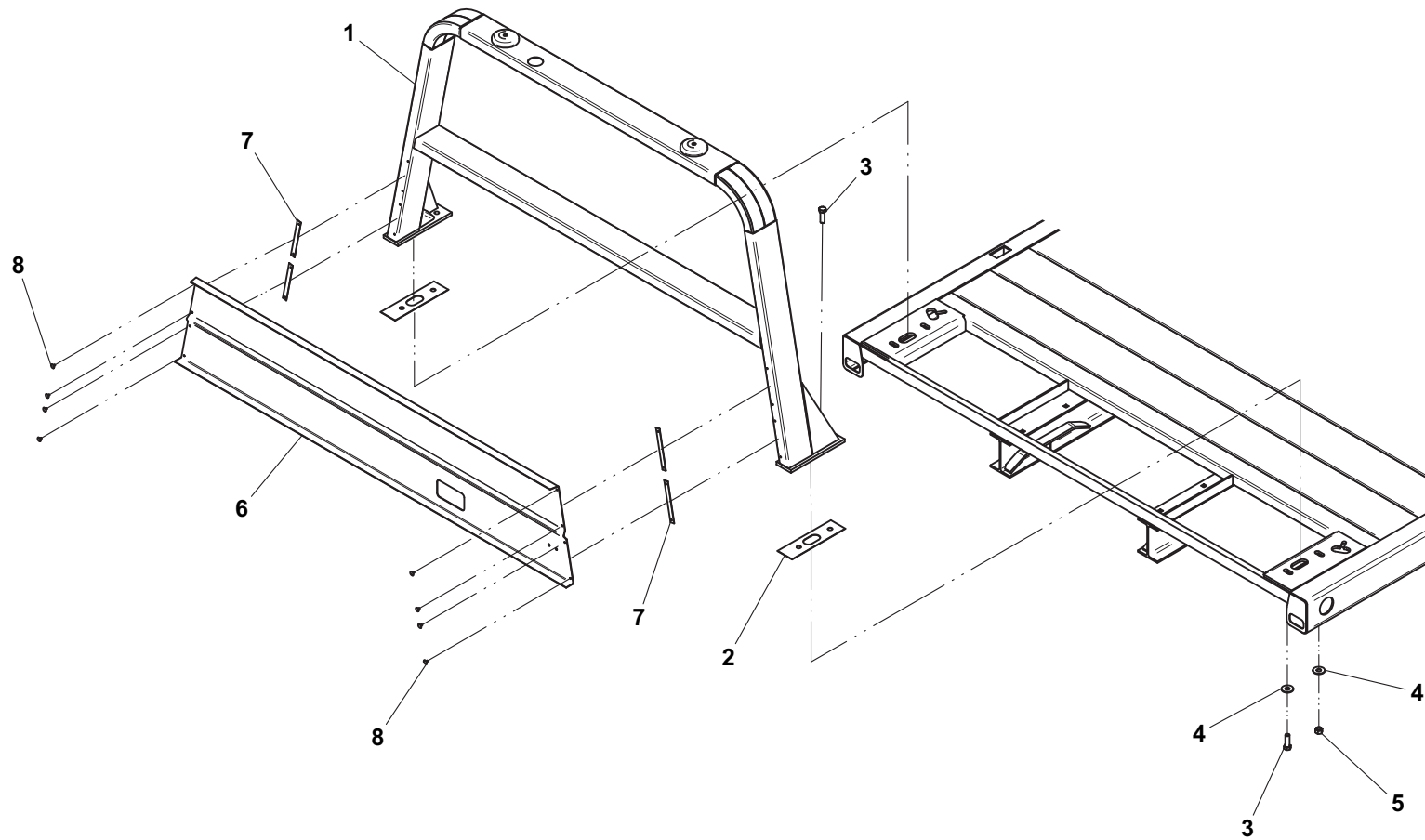

DELUXE DECK MOUNTED HEADBOARD

ITEM	PART NO.	DESCRIPTION	QTY	ITEM	PART NO.	DESCRIPTION	QTY
1	1001129151	Deluxe Headboard Weld - 36.50" Black Paint (w/ std remote free spool)	1	6	4686000295*	Panel (36.50" or 45.50" headboard w/ std remote free spool)	1
	1001129152	Deluxe Headboard Weld - 36.50" Silver Paint (w/ std remote free spool)			4686000296*	Panel (50.50" or 57.50" headboard w/ std remote free spool)	
	1001129153	Deluxe Headboard Weld - 45.50" Black Paint (w/ std remote free spool)			4686000301*	Panel (45.50" headboard w/ air remote free spool)	
	1001129154	Deluxe Headboard Weld - 45.50" Silver Paint (w/ std remote free spool)			4686000302*	Panel (50.50" or 57.50" headboard w/ air remote free spool)	
	1001129159	Deluxe Headboard Weld - 45.50" Black Paint (w/ air remote free spool)		7	4892000008*	Tape (36.50" or 45.50" headboard)	4
	1001129160	Deluxe Headboard Weld - 45.50" Silver Paint (w/ air remote free spool)		8	4892000009*	Tape (50.50" or 57.50" headboard)	
	1001129155	Deluxe Headboard Weld - 50.50" Black Paint (w/ std remote free spool)		8	7759000022*	Pop Rivet	8
	1001129156	Deluxe Headboard Weld - 50.50" Silver Paint (w/ std remote free spool)		9	3391000020	Screen Weld (36.50" headboard)	1
	1001129161	Deluxe Headboard Weld - 50.50" Black Paint (w/ air remote free spool)		9	3391000021	Screen Weld (45.50" headboard)	
	1001129162	Deluxe Headboard Weld - 50.50" Silver Paint (w/ air remote free spool)			3391000017	Screen Weld (50.50" headboard)	
	1001129157	Deluxe Headboard Weld - 57.50" Black Paint (w/ std remote free spool)			3391000022	Screen Weld (57.50" headboard)	
	1001129158	Deluxe Headboard Weld - 57.50" Silver Paint (w/ std remote free spool)		10	4796000003	Gasket	1
	1001129163	Deluxe Headboard Weld - 57.50" Black Paint (w/ air remote free spool)		11	7759000015	Rivet	6
	1001129164	Deluxe Headboard Weld - 57.50" Silver Paint (w/ air remote free spool)					
2	4796000037	Gasket	2				
3	7105201650	Capscrew, 0.63"-18NF x 2.00"	4				
4	7950200152	Flatwasher, 0.63" ID	4				
5	7660200035	Nut, 0.63"-18NF	2				

* included with Deluxe Headboard Weld

DELUXE DECK MOUNTED HEADBOARD

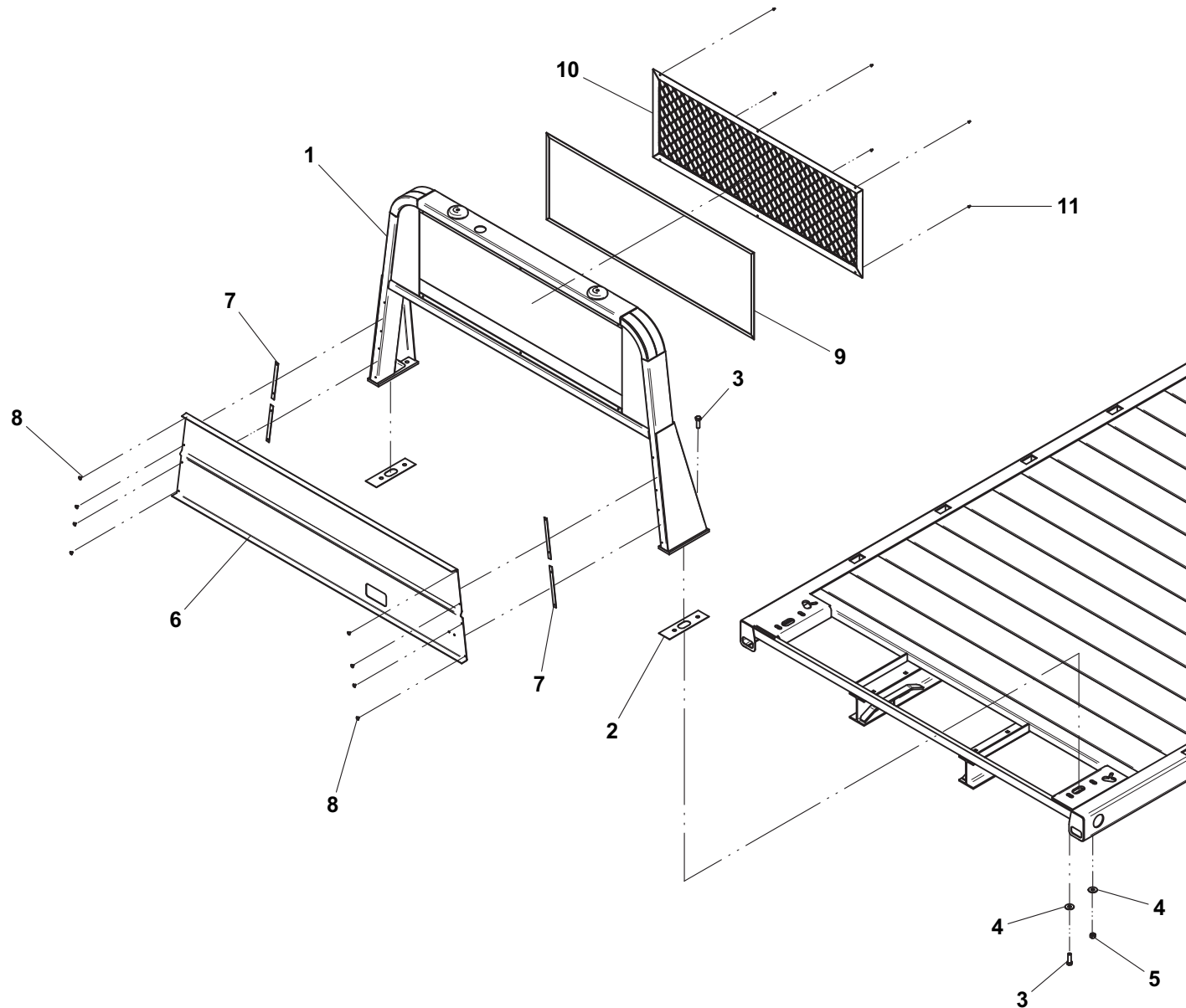

BUCKET REST HEADBOARD

ITEM	PART NO.	DESCRIPTION	QTY
1	3636000078	Lightbar Mount	2
2	7115161050	Capscrew, 0.38"-16NC x 1.25"	4
3	7660161600	Locknut, 0.38"-16NC	4
4	7950160160	Flatwasher, 0.38" ID	4

BUCKET REST HEADBOARD

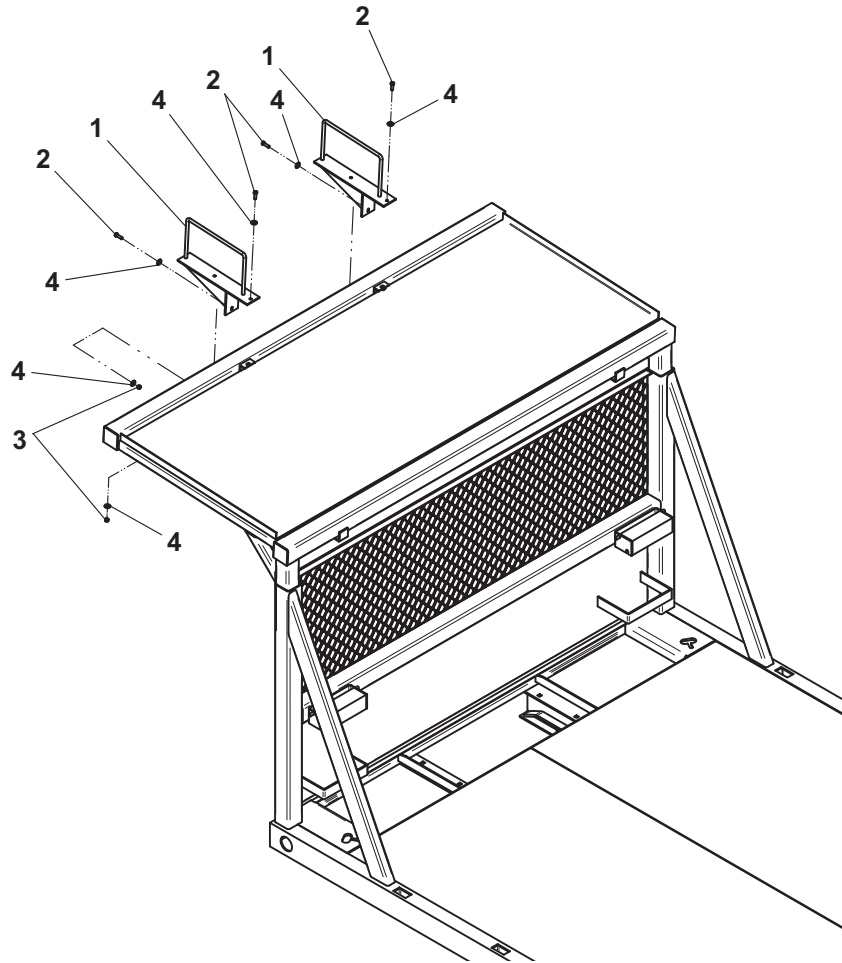

STATIONARY HEADBOARD

ITEM	PART NO.	DESCRIPTION	QTY
1	1001129165	Stationary Headboard Weld - 57.00" Black Paint	1
	1001129166	Stationary Headboard Weld - 57.00" Silver Paint	
	1001129167	Stationary Headboard Weld - 62.00" Black Paint	
	1001129168	Stationary Headboard Weld - 62.00" Silver Paint	
	1001129169	Stationary Headboard Weld - 69.00" Black Paint	
	1001129170	Stationary Headboard Weld - 69.00" Silver Paint	
2	7105181650	Capscrew, 0.50"-20NF x 2.00"	8
3	7950180153	Flatwasher, 0.50" ID	8
4	7660182333	Locknut, 0.50"-20NF	8
5	3391000014	Screen Weld (57.00" headboard)	1
	3391000017	Screen Weld (62.00" headboard)	
	3391000018	Screen Weld (69.00" headboard)	
6	4796000003	Gasket	1
7	7759000015	Rivet	6
8	4705000607	Shim - 0.25"	A/R
9	4705000608	Shim - 0.12"	A/R

STATIONARY HEADBOARD

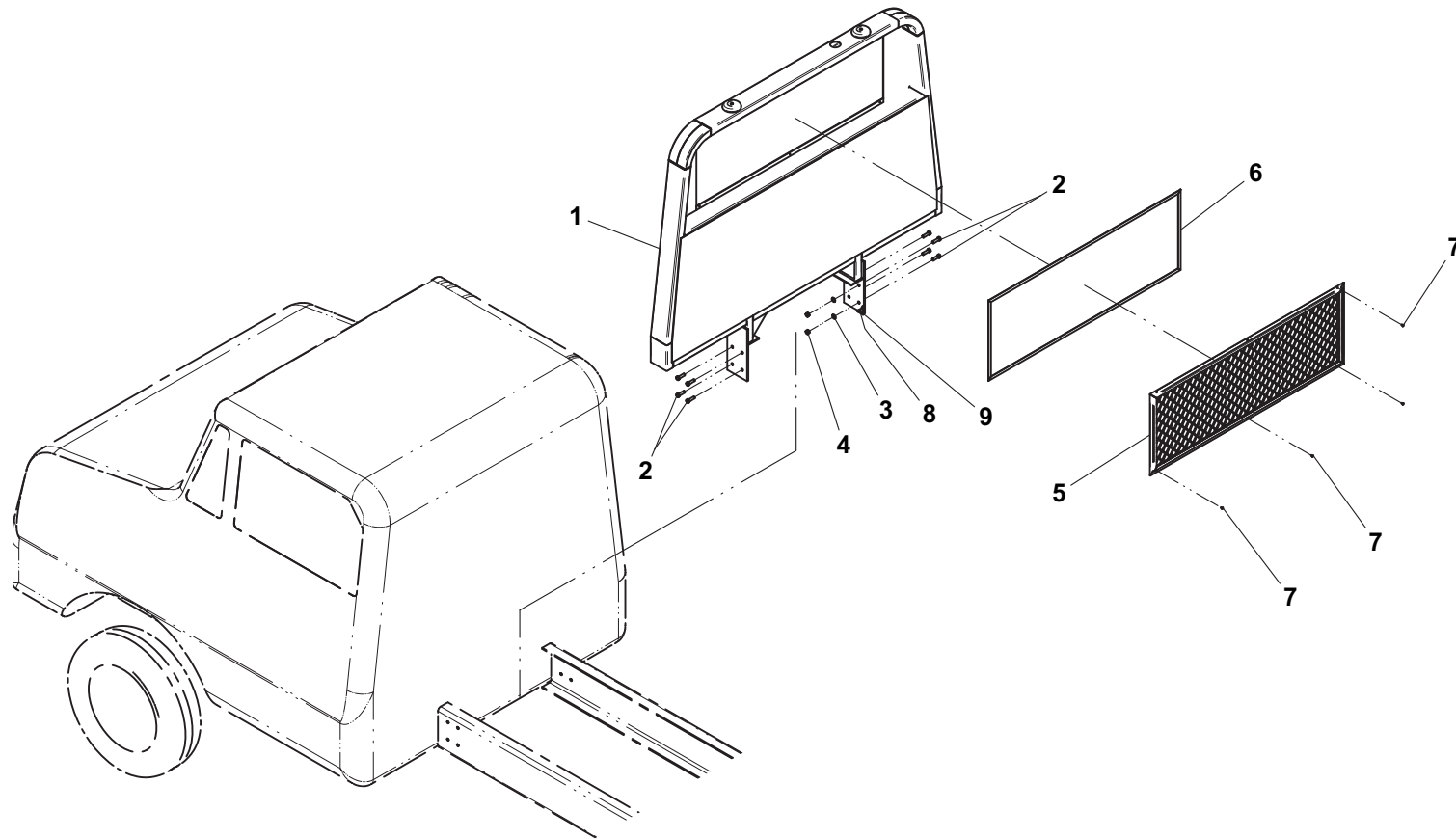

WORM GEAR WINCH

ITEM	PART NO.	DESCRIPTION	QTY
1	7970000121	Winch - 8,000 lb Worm Gear (w/ std remote free spool)	1
	7970000142	Winch - 8,000 lb Worm Gear (w/ air remote free spool)	
	7970000123	Winch - 10,000 lb Worm Gear (w/ std remote free spool)	
	7970000140	Winch - 10,000 lb Worm Gear (w/ air remote free spool)	
2	7626000014	Orbit Motor	1
3	7115181250	Capscrew, 0.50"-13NC x 1.50"	2
4	7950180400	Lockwasher, 0.50" ID	2
5	7115181464	Carriage Bolt, 0.50"-13NC x 1.75" (steel decks)	3
	7115182864	Carriage Bolt, 0.50"-13NC x 3.5" (steel transporters)	
	7115181864	Carriage Bolt, 0.50"-13NC x 2.25" (aluminum decks)	
	7115183264	Carriage Bolt, 0.50"-13NC x 4.00" (aluminum transporters)	
6	7115181864	Carriage Bolt, 0.50"-13NC x 2.25" (steel decks)	1
	7115183264	Carriage, 0.50"-13NC x 4.00" (steel transporters)	
	7115182264	Carriage Bolt, 0.50"-13NC x 2.75" (aluminum decks)	
	7115183664	Capscrew, 0.50"-13NC x 4.50" (aluminum transporters)	
7	7950180153	Flatwasher, 0.50" ID	4
8	7660182601	Locknut, 0.50"-13NC	4
9	4062000318	Bar (transporters only)	2
10	7248000063	Cable, 0.38" dia x 56' (8,000lb winch)	1
	7248000064	Cable, 0.44" dia x 56' (10,000lb winch)	

Refer to manufacturer's manual for winch parts list

WORM GEAR WINCH

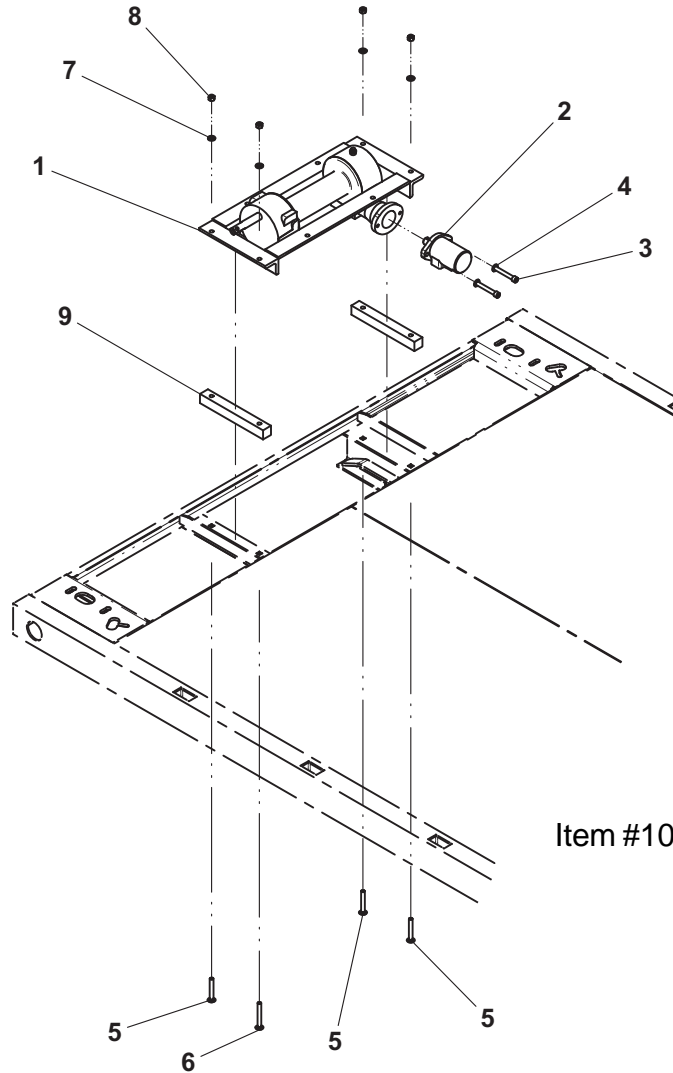

Item #10, Winch Cable, not shown

8,000 lb winch shown on transporter deck

WORM GEAR WINCH CABLE ROLLER GUIDE / TENSIONER PLATE

ITEM	PART NO.	DESCRIPTION	QTY
1	3178000433*	Bracket Weld	1
2	7115181464	Carriage Bolt, 0.50"-13NC x 1.75"	4
3	7950180153	Flatwasher, 0.50" ID	4
4	7660182601	Locknut, 0.50"-13NC	4
5	4706003766	Plate	1
6	7843000035	Spring	2
7	4912000130*	Roller	1
8	4806000014*	Shaft	1
9	4912000394*	Roller	2
10	4806000011*	Shaft	2
11	7209000011*	Bushing	6
12	7949000034*	Spacer	4
13	7754000022*	Retaining Ring	6

* also available in Cable Guide / Tensioner Assembly, P/N 2249000017

WORM GEAR WINCH CABLE ROLLER GUIDE / TENSIONER PLATE

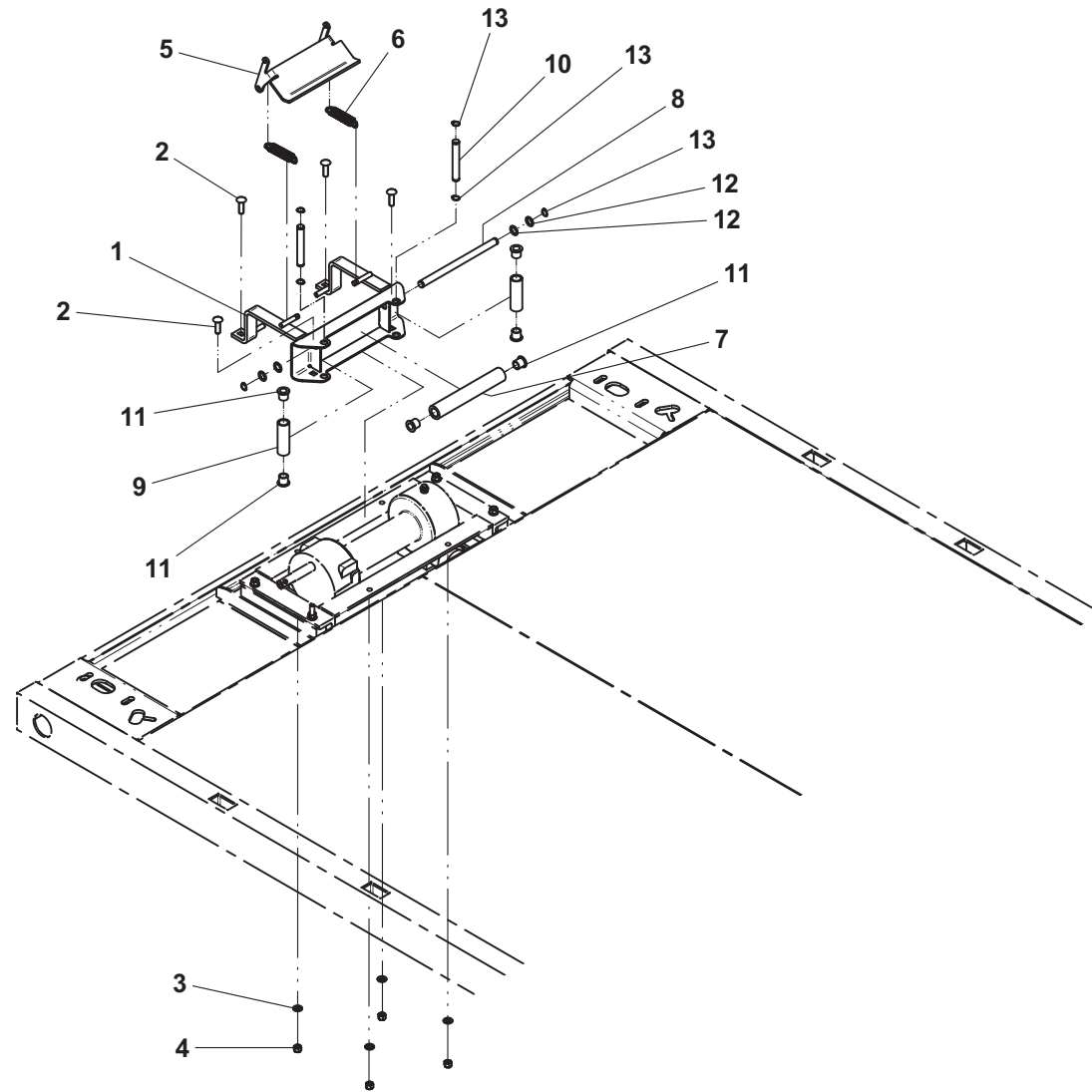

8,000 lb winch shown

MANUAL REMOTE FREE SPOOL - DECK MOUNTED HEADBOARD

ITEM	PART NO.	DESCRIPTION	QTY
1	4587000004*	Lever	1
2	4209000328*	Bushing	1
3	7082000010*	Nylon Washer	2
4	7950180161*	Flatwasher, 0.50" ID	1
5	7309000002*	Coupling	1
6	7691000046*	Clevis Pin	1
7	7660182631*	Locknut, 0.50"-20NF	1
8	7950180143*	Flatwasher, 0.50" ID	2
9	4763000348*	Rod	1
10	7660180234*	Nut, 0.50"-20NF	1
11	4178000673*	Bracket	1
12	7115150850*	Capscrew, 0.31"-18NC x 1.00"	2
13	7950150161*	Flatwasher, 0.31" ID	4
14	7660152601*	Locknut, 0.31"-18NC	2
15	4209000147*	Bushing (worm gear winch)	1
	4209000145*	Bushing (planetary gear winch)	
16	7690051274*	Pin	2
17	7949000030*	Nylon Washer	1
18	7843000027*	Spring	1
19	7551000017*	Knob	1
20	4632000009*	Trim Lok	1

* also available in complete Remote Free Spool Installation:

P/N 2970000021 for 8,000 / 10,000 lb worm gear winch

P/N 2970000019 for 8,000 lb planetary gear winch

MANUAL REMOTE FREE SPOOL - DECK MOUNTED HEADBOARD

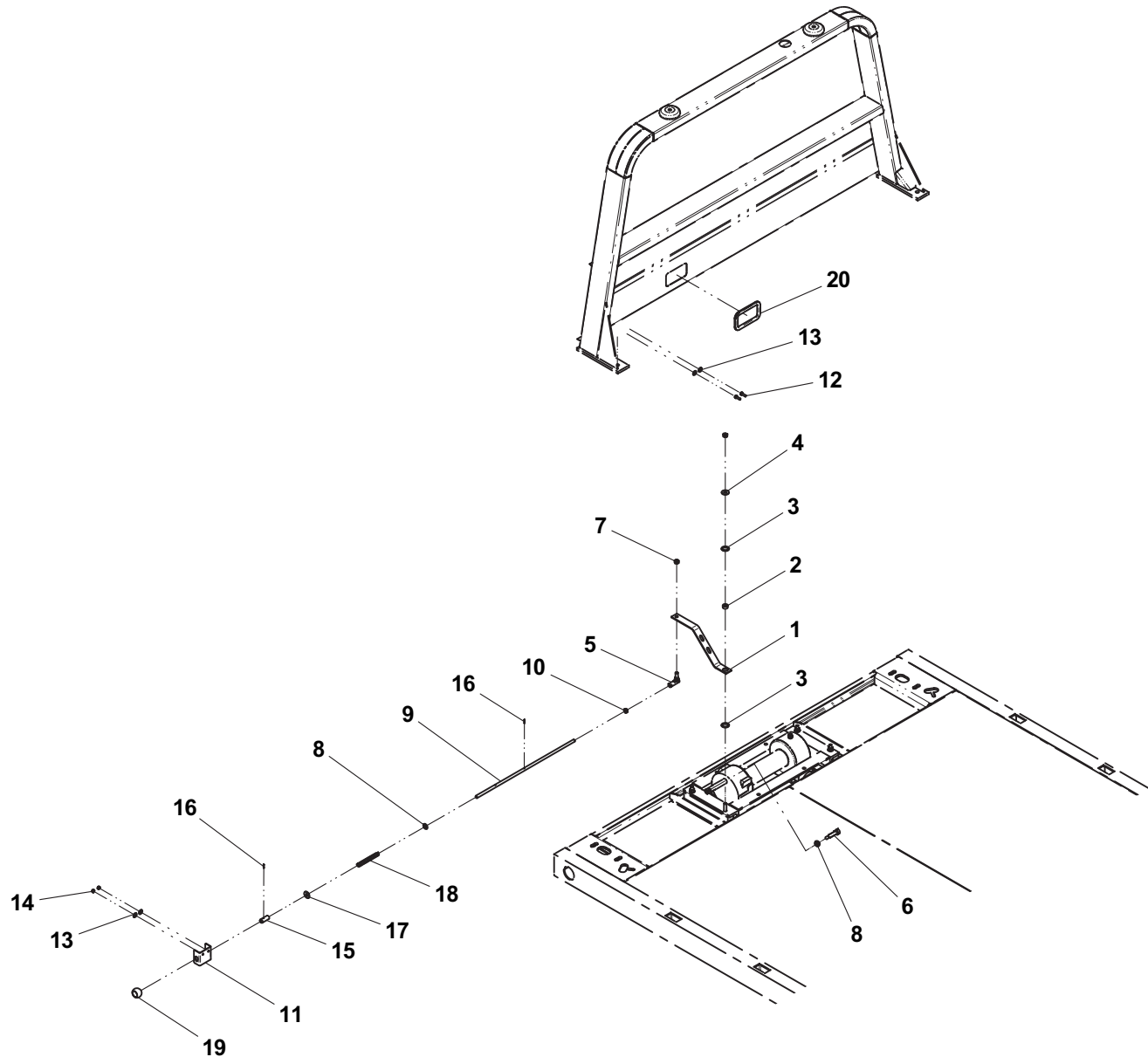

MANUAL REMOTE FREE SPOOL - STATIONARY HEADBOARD

ITEM	PART NO.	DESCRIPTION	QTY
1	4587000005*#	Lever	1
2	4209000328*#	Bushing	1
3	7082000010*#	Nylon Washer	2
4	7950180161*#	Flatwasher, 0.50" ID	1
5	7309000002*#	Coupling	1
6	7691000046*#	Clevis Pin	1
7	7660182631*#	Locknut, 0.50"-20NF	1
8	7950180143*#	Flatwasher, 0.50" ID	2
9	4763000348*#	Rod	1
10	7660180234*#	Locknut, 0.50"-20NF	1
11	4178000674*	Bracket (steel decks)	1
	4017001499#	Bracket (aluminum decks)	
12	4178000673*#	Bracket	1
13	7115150850*#	Capscrew, 0.31"-18NC x 1.00"	2
14	7950150161*#	Flatwasher, 0.31" ID	4
15	7660152601*#	Locknut, 0.31"-18NC	2
16	4209000147*#	Bushing (worm gear winch)	1
	4209000145*#	Bushing (planetary gear winch)	
17	7690051274*#	Pin	2
18	7949000030*#	Nylon Washer	1
19	7843000027*#	Spring	1
20	7551000017*#	Knob	1

also available in complete Remote Free Spool Installation - aluminum deck :
P/N 2970000053 for 8,000 / 10,000 lb worm gear winch
P/N 2970000051 for 8,000 lb planetary gear winch

* also available in complete Remote Free Spool Installation - steel deck:
P/N 2970000052 for 8,000 / 10,000 lb worm gear winch
P/N 2970000050 for 8,000 lb planetary gear winch

MANUAL REMOTE FREE SPOOL - STATIONARY HEADBOARD

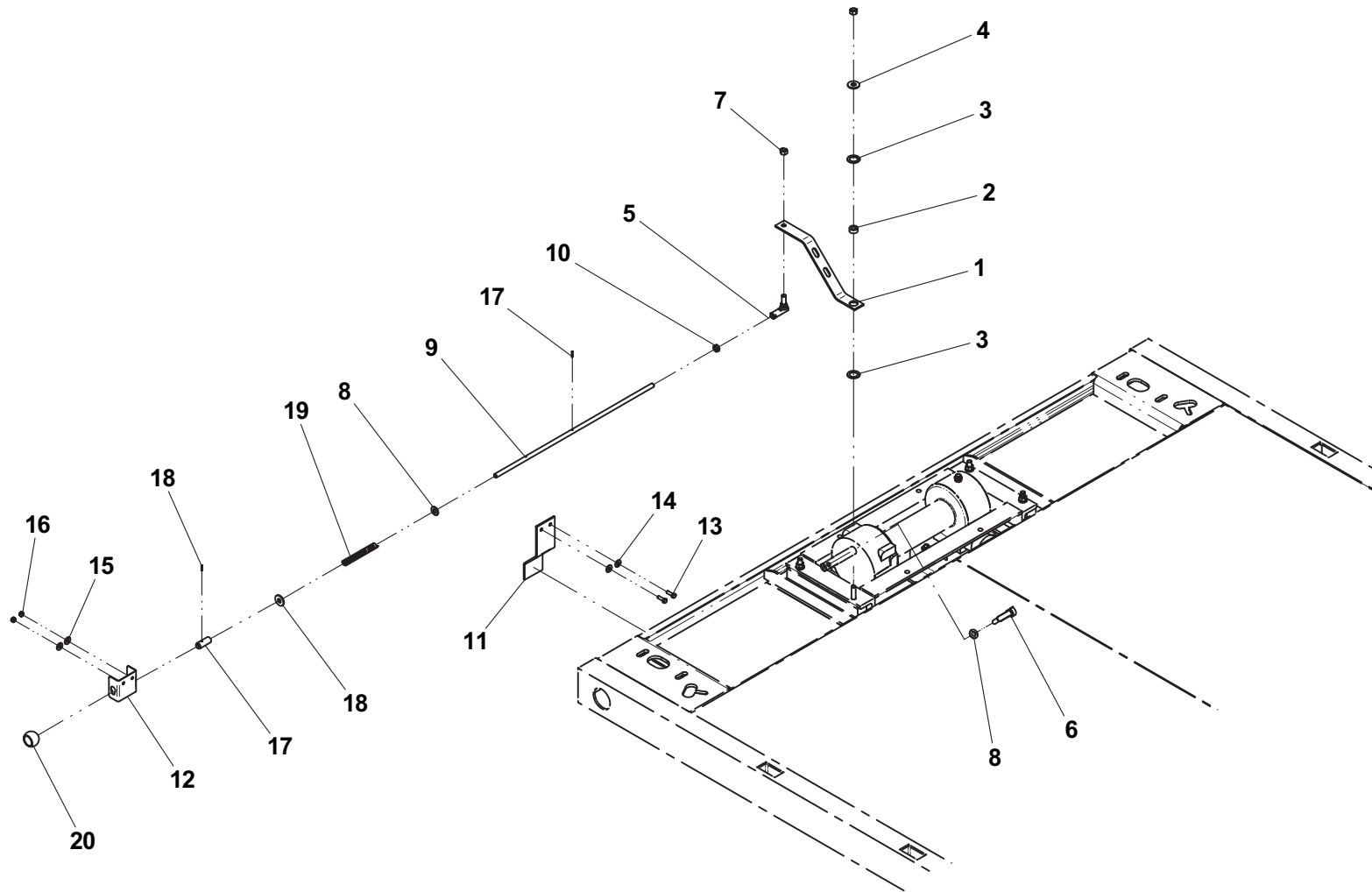

MANUAL REMOTE AIR FREE SPOOL

ITEM	PART NO.	DESCRIPTION	QTY
1	7565000014	Air line Tubing	*
2	7935000182	Air Valve	2
3	7443000364	Fitting	5
4	7640000002	Air Exhaust Muffler	2
5	7443000154	Fitting	1
6	7443000111	Fitting	1
7	7443000156	Nipple	2
8	7935000120	Pressure Protection Valve	1
9	7443000152	Plug	1
10	7443000366	Fitting	1
11	7935000248	Air Regulator	1
12	7443000371	Tee	1
13	7443000365	Fitting	2
14	8597650001	Loom	*
15	7935000229	Shuttle Valve	1
16	7894000004	Tie Strap	*
17	7443000443	Union	1
18	7565000016	Airline Tubing	*

* - Quantity varies depending on deck length and chassis

MANUAL REMOTE AIR FREE SPOOL

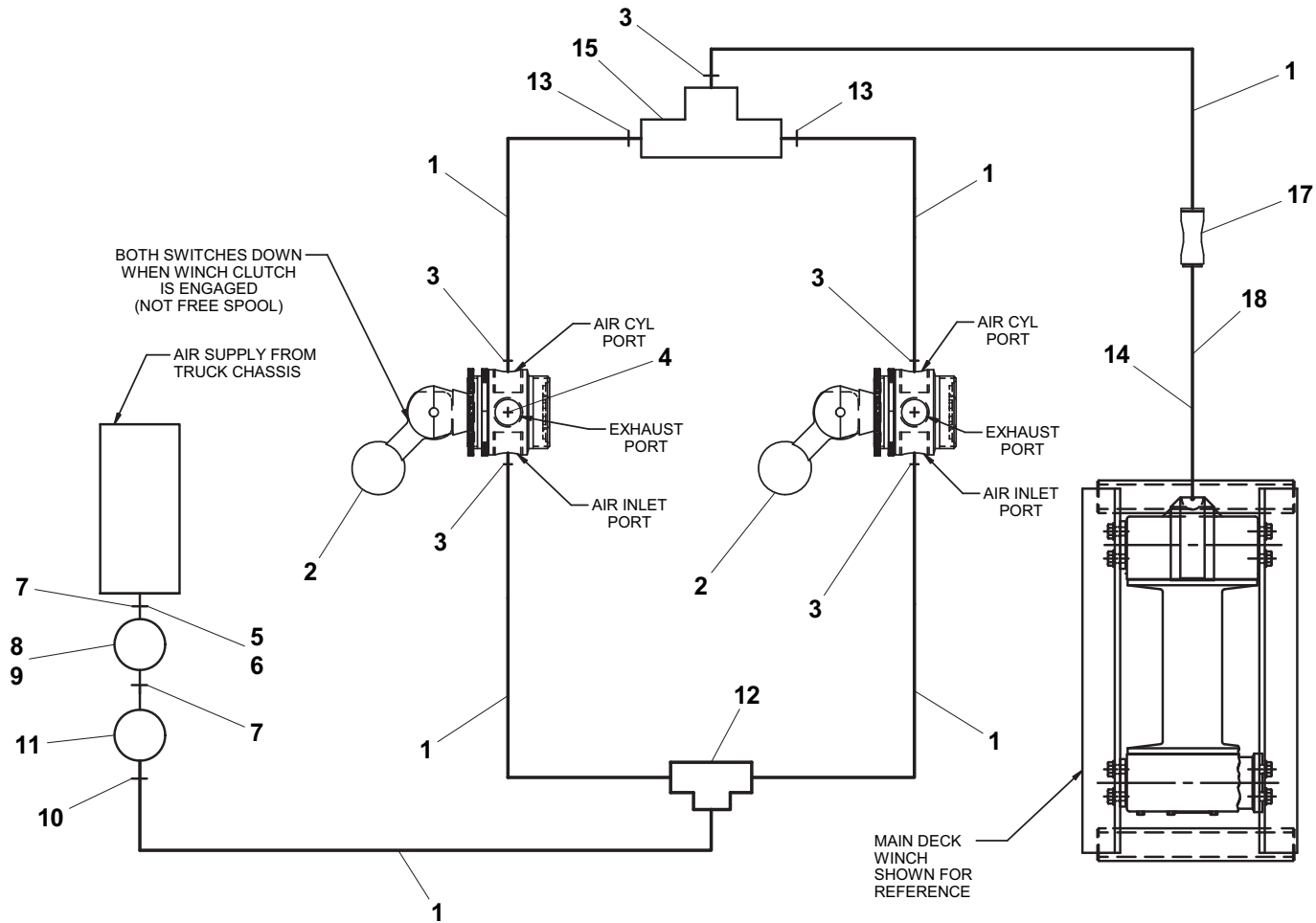

SUBFRAME

ITEM	PART NO.	DESCRIPTION	QTY	ITEM	PART NO.	DESCRIPTION	QTY
1	3868000316	Subframe Weld - Standard	1	31	7950200242	Flatwasher, 0.63 ID	8
	3868000318	Subframe Weld - Galvanized		32	7105201850	Capscrew, 0.63"-18NF x 2.25"	8
2	3905000014	Trunnion Weld	1	33	4209000358	Bushing	2
3	7950160161	Flatwasher, 0.38 ID	1	34	7115181464	Carriage Bolt, 0.50"-13NC x 1.75"	4
4	3320000238	Roll Cylinder Assembly	1	35	7660182601	Locknut, 0.50"-13NC	8
5	3320000122	Tilt Cylinder Assembly	2				
6	4178000805	Bracket	2				
7	7949000008	Washer, 2.25" ID	2				
8	4691000573	Pin	2				
9	7115162450	Capscrew, 0.38"-16NC x 3.00"	2				
10	7660162601	Locknut, 0.38"-16NC	7				
11	7118161026	Capscrew, 0.38"-16NC x 1.25"	1				
12	7189000026	Bumper, Polyurethane	4				
13	7114141450	Capscrew, 0.25"-20NC x 1.75"	2				
14	7660142604	Locknut, 0.25"-20NC	2				
15	7950140143	Flatwasher, 0.25" ID	6				
16	4178000912	Bracket	2				
17	3691000166	Pin Weld	2				
18	7115221650	Capscrew, 0.75"-10NC x 2.00"	4				
19	7950180153	Flatwasher, .050" ID	12				
20	7660102604	Locknut, #10-24NC	2				
21	7115161050	Capscrew, 0.38"-16NC x 1.25"	4				
22	4209000337	Bushing	8				
23	3636000144	Mount, Roll Trunnion	2				
24	7701000048	Plug	4				
25	7660202347	Locknut, 0.63"-18NF	8				
26	7114100818	Capscrew, #10-24NC x 1.00"	2				
27	4706006405	Plate, Tray	1				
28	3691000273	Pin Weld	2				
29	7115180650	Capscrew, 0.50"-13NC x 0.75"	2				
30	7949000072	Washer, 0.50 ID	2				

SUBFRAME

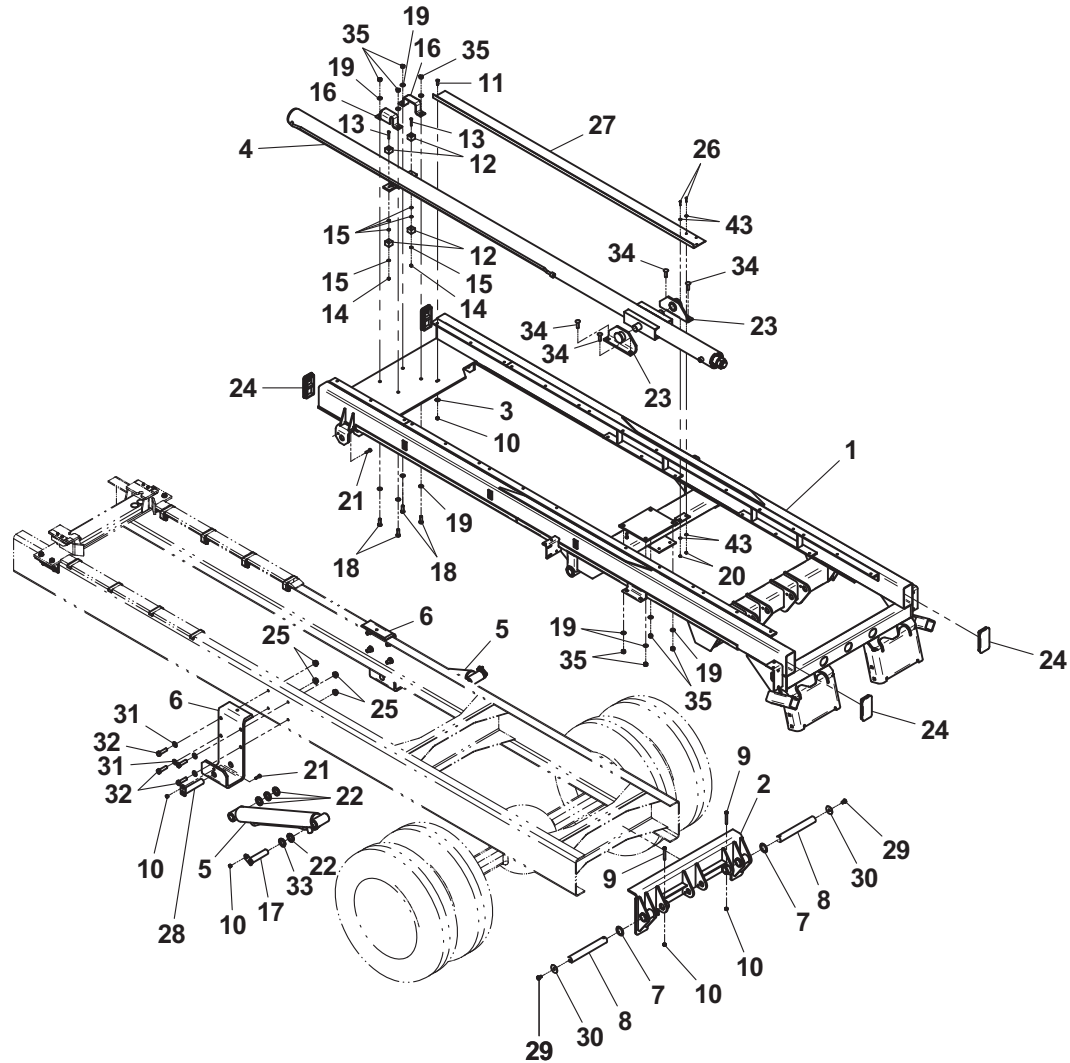

HOLD DOWN

ITEM	PART NO.	DESCRIPTION	QTY
1	3558000019*	Hold Down Weld	1
2	4017001271	Angle	2
3	7105181650	Capscrew, 0.50"-20NF x 2.00"	8
4	7950180153	Flatwasher, 0.50" ID	8
5	7660182333	Locknut, 0.50"-20NF	4
6	4679000332	Wear Pad	2
7	7274000125	Clamp	8
8	7120000032	Screw, 0.38"-16NF x 1.75"	8
9	7701000063	Plug	4
10	4679000221*	Wear Pad	2
11	4812000071*	Shim - 0.12"	2
12	4812000072*	Shim - 0.06"	2
13	7114151218*	Capscrew, 0.31"-18NC x 1.50"	4
14	7660152601*	Locknut, 0.31"-18NC	4

* also available in Hold Down Assembly, P/N 3558000019

HOLD DOWN

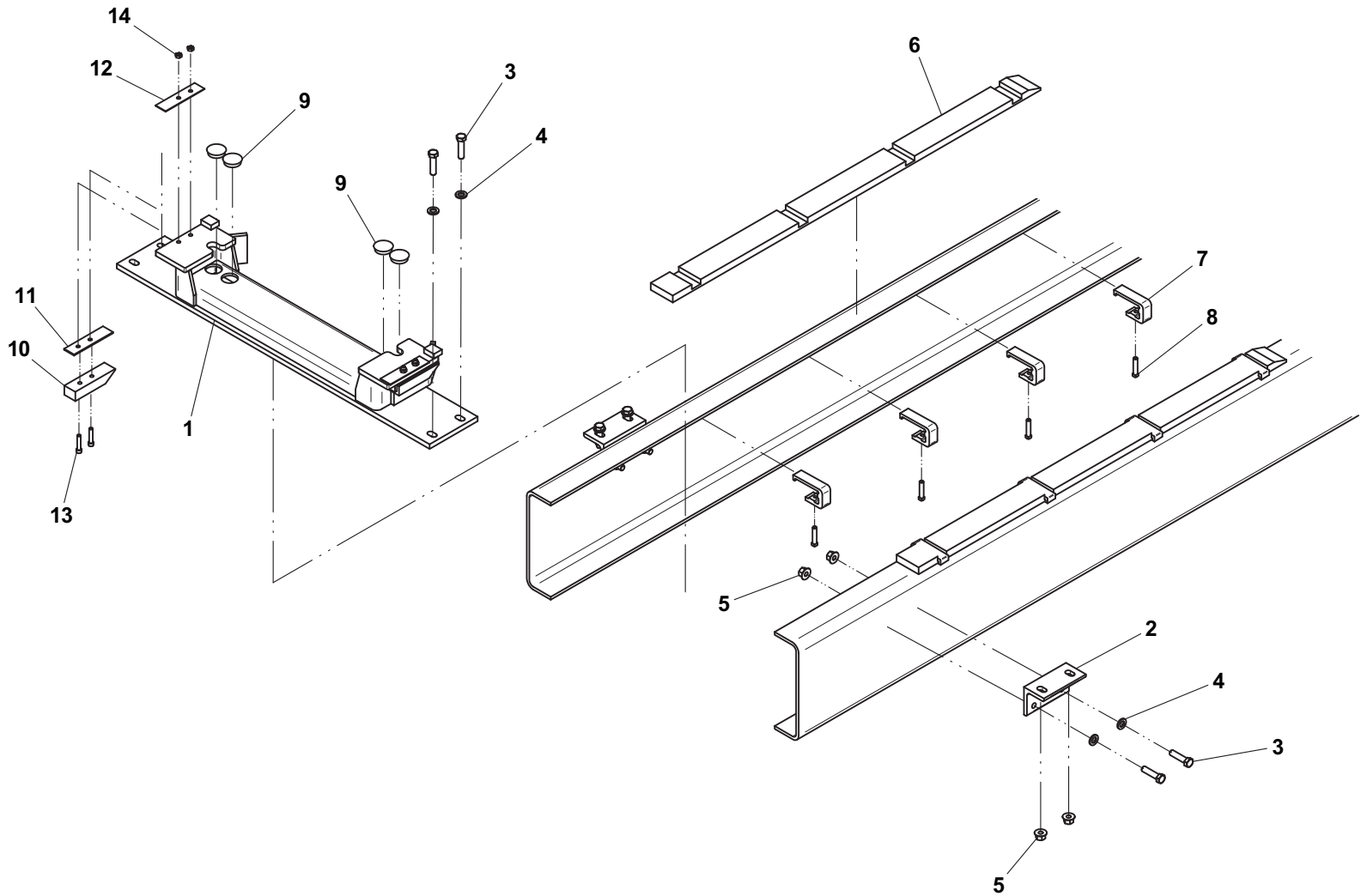

SLIDE PAD

ITEM	PART NO.	DESCRIPTION	QTY
1	4679000145	Wear Pad	14
2	7118161026	Screw, 0.38"-16NC x 1.25"	42
4	7660162601	Locknut, 0.38"-16NC	42

SLIDE PAD

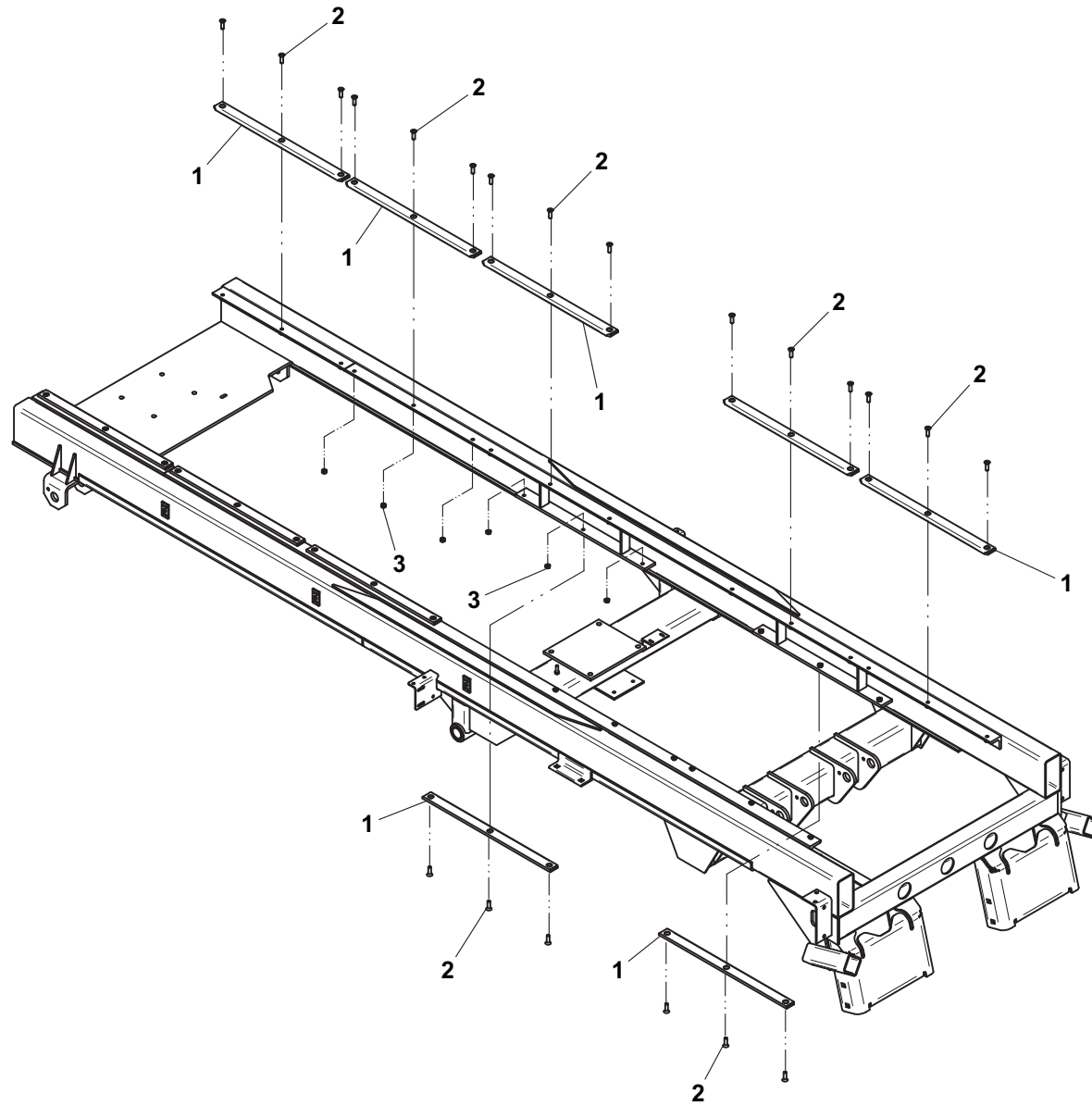

MUD FLAP

ITEM	PART NO.	DESCRIPTION	QTY
1	7638000004	Mud Flap	2
2	4017001742	Plate, LH	1
3	4017001743	Plate, RH	1
4	4706006427	Plate	2
5	7111150864	Carriage Bolt, 0.31"-18NC x 1.00"	8
6	7660152601	Locknut, 0.31"-18NC	14
7	7114150818	Capscrew, 0.31"-18NC x 1.00"	6
8	7950150153	Flat Washer, 0.31" ID	6

MUD FLAP

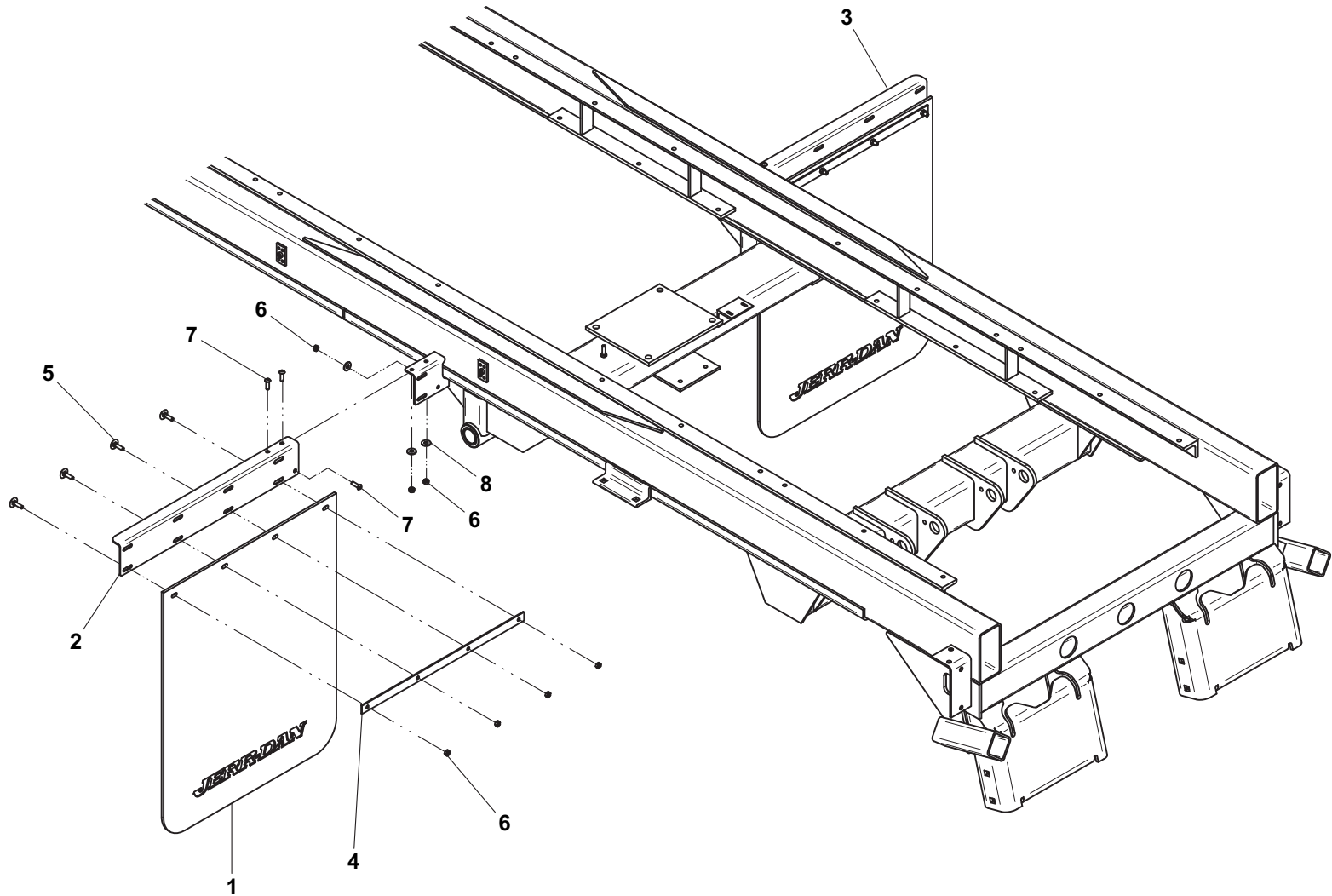

LIGHTBOXES

ITEM	PART NO.	DESCRIPTION	QTY
1	4314000235	Coverplate - Standard	1
	4314000072	Coverplate - Galvanized	2
2	7114140529	Screw, 0.25"-20NC x 0.63"	8
3	7661000042	U-Nut, 0.25"-20NC	8
4	7949000023	Nylon Washer, 0.26" ID	8
5	3178000544	Lightbox - LH	1
6	3178000545	Lightbox - RH	1
7	7114150818	Capscrew, 0.31"-18NC x 1.00"	8
8	7950150153	Flatwasher, 0.31" ID	8
9	7660152601	Locknut, 0.31"-18NC	8
10	4314000232	Coverplate - Standard	1
	4178000863	Bracket - Galvanized	

LIGHTBOXES

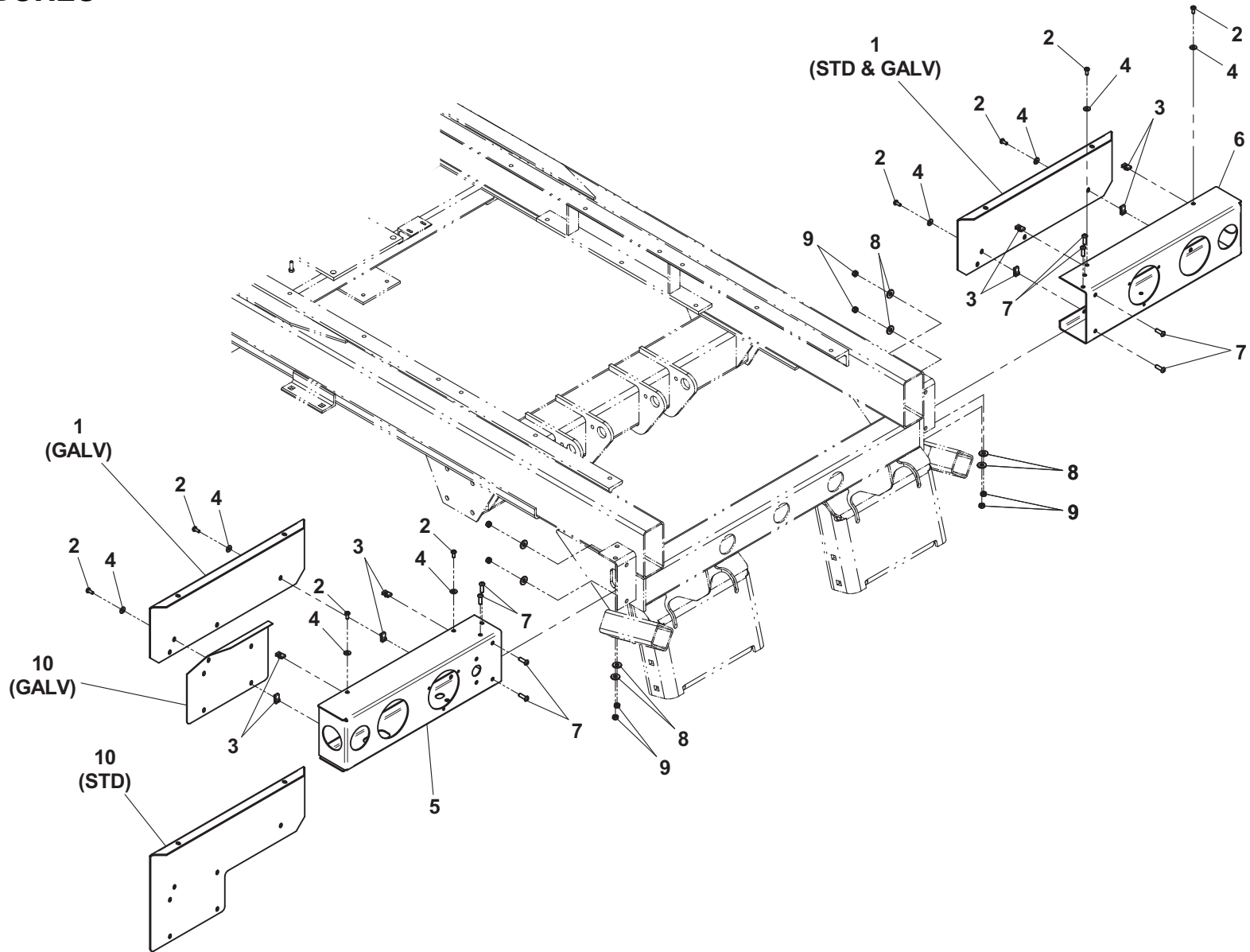

FINAL ASSEMBLY

ITEM	PART NO.	DESCRIPTION	QTY
1	3190000058	Bumper Tube Weld - Short - Standard	2
	3190000060	Bumper Tube Weld - Short - Galvanized	
2	7115181064	Carriage Bolt, 0.50"-13NC x 1.25"	8
3	7660182601	Locknut, 0.50"-13NC	8
4	7493000023	Grommet	3
5	7590000343	Marker Light - Red (LED)	4
6	7590000341	Stop/Tail/Turn Light - Red (LED)	2
7	7493000010	Grommet	1
8	7590000103	License Plate Light	1
9	7011000007	Back-Up Alarm	1
10	7114140528	Screw, 0.25"-20NC x 0.63"	2
11	7949000023	Nylon Washer, 0.26" ID	10
12	7660142601	Locknut, 0.25-20NC	2
13	7493000002	Grommet	4
14	7590000340	Marker Light - Red (LED)	3
15	7493000009	Grommet	4
16	7590000113	Back-Up Light - White (Std)	2
17	7701000049	Plug	1
18	7701000055	Plug	2
19	7661000064	U-Nut Clip, 0.25"-20NC	8
20	4314000200	Cover Plate - Standard	2
	4314000204	Cover Plate - Galvanized	
21	7950140000	Lockwasher, 0.25" ID	8
22	7115140850	Capscrew, 0.25"-20NC x 1.00"	8
23	7330000428	Reflective Tape	2
24	7679000020	Non-Skid Pad	2

FINAL ASSEMBLY

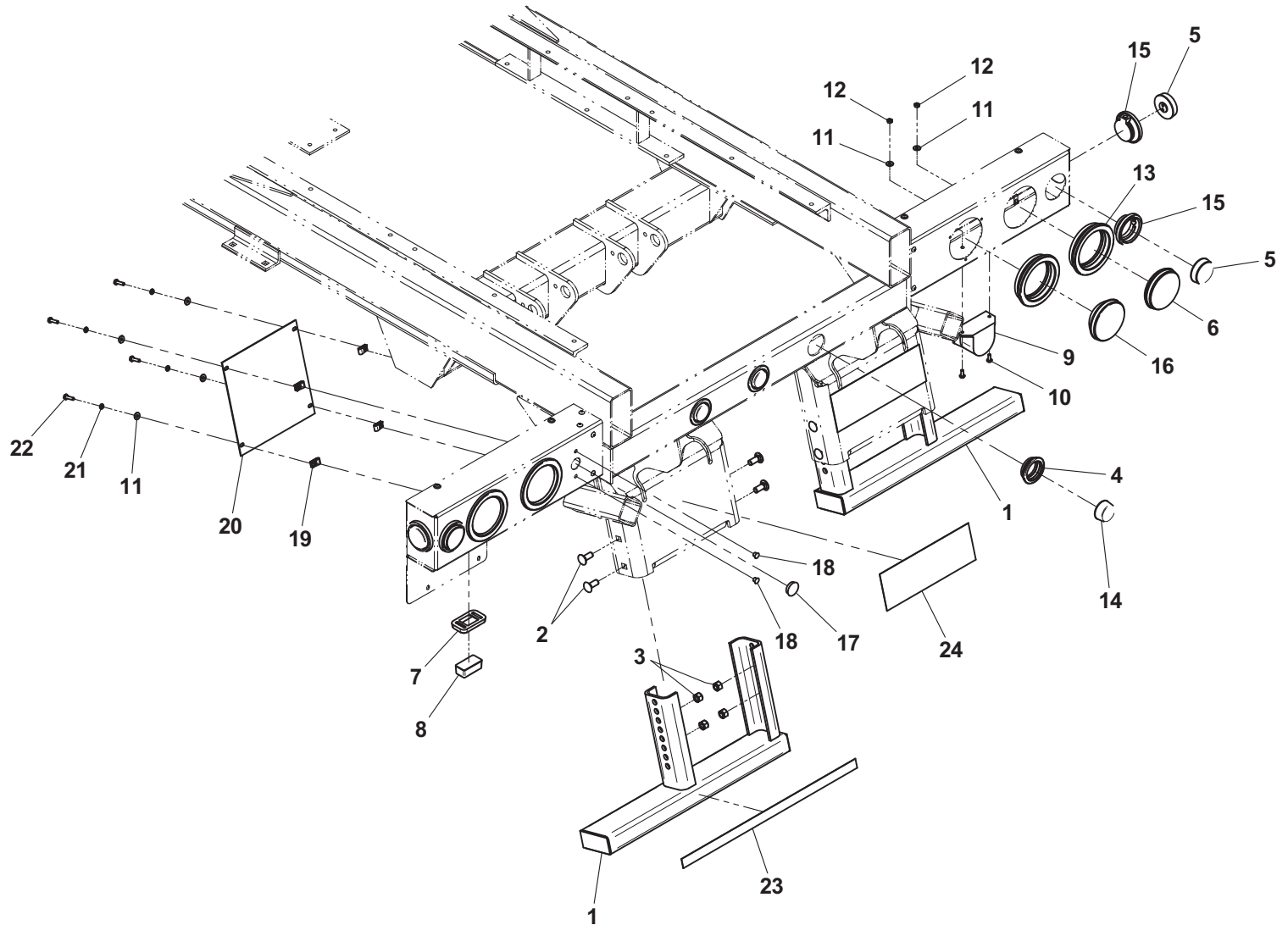

HYDRAULIC RESERVOIR AND TOOLBOX / BASKET

ITEM	PART NO.	DESCRIPTION	QTY*	ITEM	PART NO.	DESCRIPTION	QTY*
1	4178000331	Mounting Bracket - Short		20	4632000015	Moulding - 15" deep basket	
	4178000291	Mounting Bracket - Std			4632000048	Moulding - 24" deep basket	
	4178000339	Mounting Bracket - Long		21	7002000410	Stainless Steel Cover Plate for Basket includes rivets	
2	4178000330	Mounting Bracket - Short		22	3178000566	Bracket Weldment	
	4178000290	Mounting Bracket - Std		23	7701000051	Plug	
	4178000338	Mounting Bracket - Long					
3	3750000018	Hydraulic Reservoir Assembly					
4	7183000004+	Breather Filler Cap Assembly					
5	7470000027+	Level Gauge					
6	7430000014+	Strainer					
7	7105181650	Capscrew, 0.50"-20NF x 2.00"					
8	7950180153	Flat Washer, 0.50" ID					
9	7660182333	Locknut, 0.50"-20NF					
10	7115150850	Capscrew, 0.31"-18NC x 1.00"					
11	7950150161	Flatwasher, 0.31" ID					
12	7660152601	Locknut, 0.31"-18NC					
13	3899000130	Toolbox Assembly - 36" x 18" x 18"					
	3899000131	Toolbox Assembly - 36" x 18" x 14"					
	3899000132	Toolbox Assembly - 48" x 18" x 18"					
	3899000133	Toolbox Assembly - 60" x 18" x 18"					
	3899000172	Toolbox Assembly - 78" x 21" X 20"					
14	4679000256^	Rubber Pad (36" toolbox)					
	4679000257^	Rubber Pad (48" toolbox)					
	4679000258^	Rubber Pad (60" toolbox)					
	4679000322^	Rubber Pad (78" toolbox)					
15	7118181216	Capscrew, 0.50"-13NC x 1.50"					
16	7660182301	Locknut, 0.50"-13NC					
17	4706002361	Plate					
18	4017000777	High Mount Angle					
19	3899000053	Basket - 15" deep					
	3899000075	Basket - 24" deep					

+ also available in Hydraulic Reservoir Assembly, P/N 3750000018

^ included in Toolbox Assembly

* Quantities vary depending on Hydraulic Tank / Toolbox / Basket mounting configuration.

HYDRAULIC RESERVOIR AND TOOLBOX / BASKET

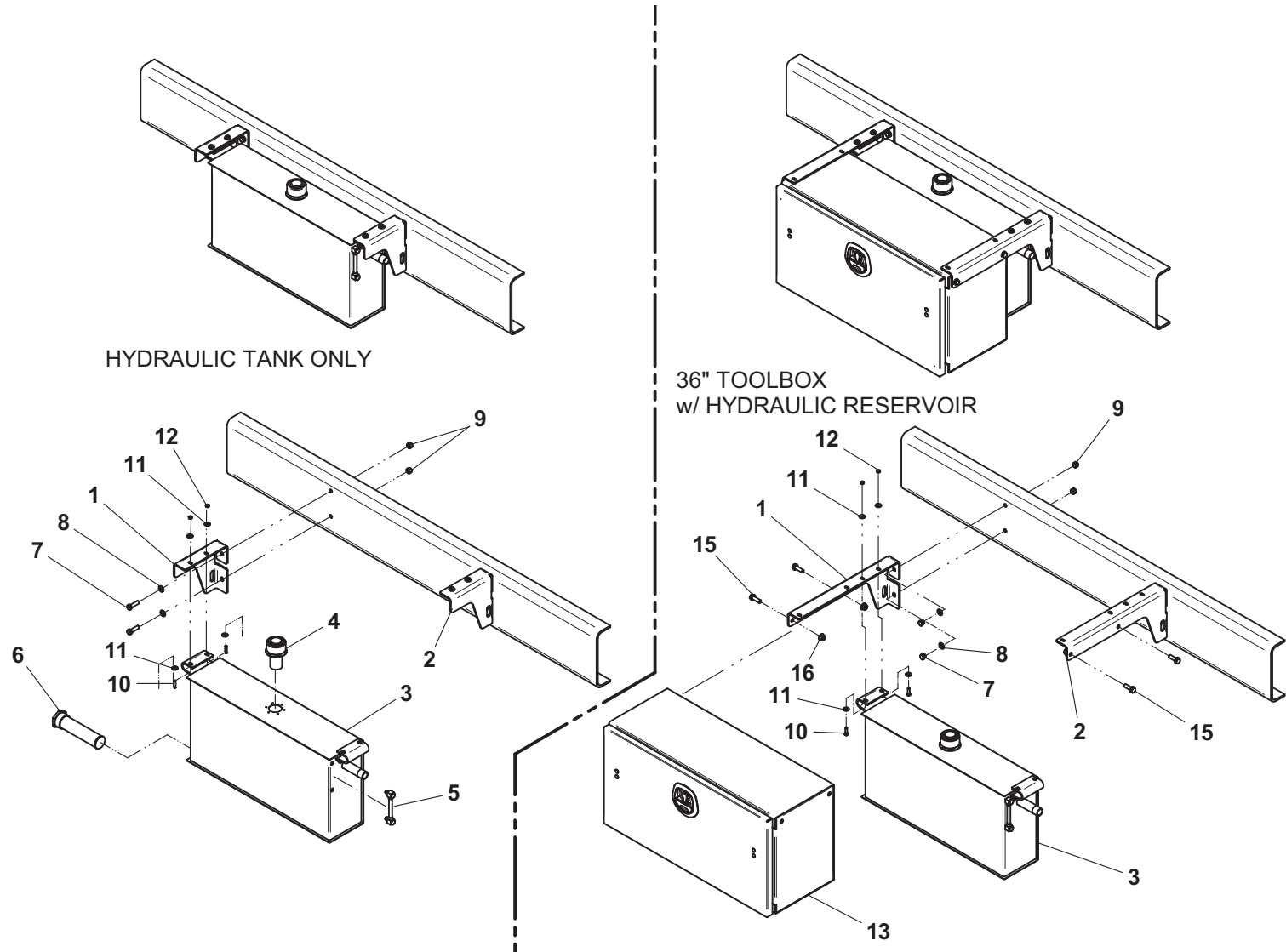

Item #14, Toolbox Rubber Pad, not shown

HYDRAULIC RESERVOIR AND TOOLBOX / BASKET

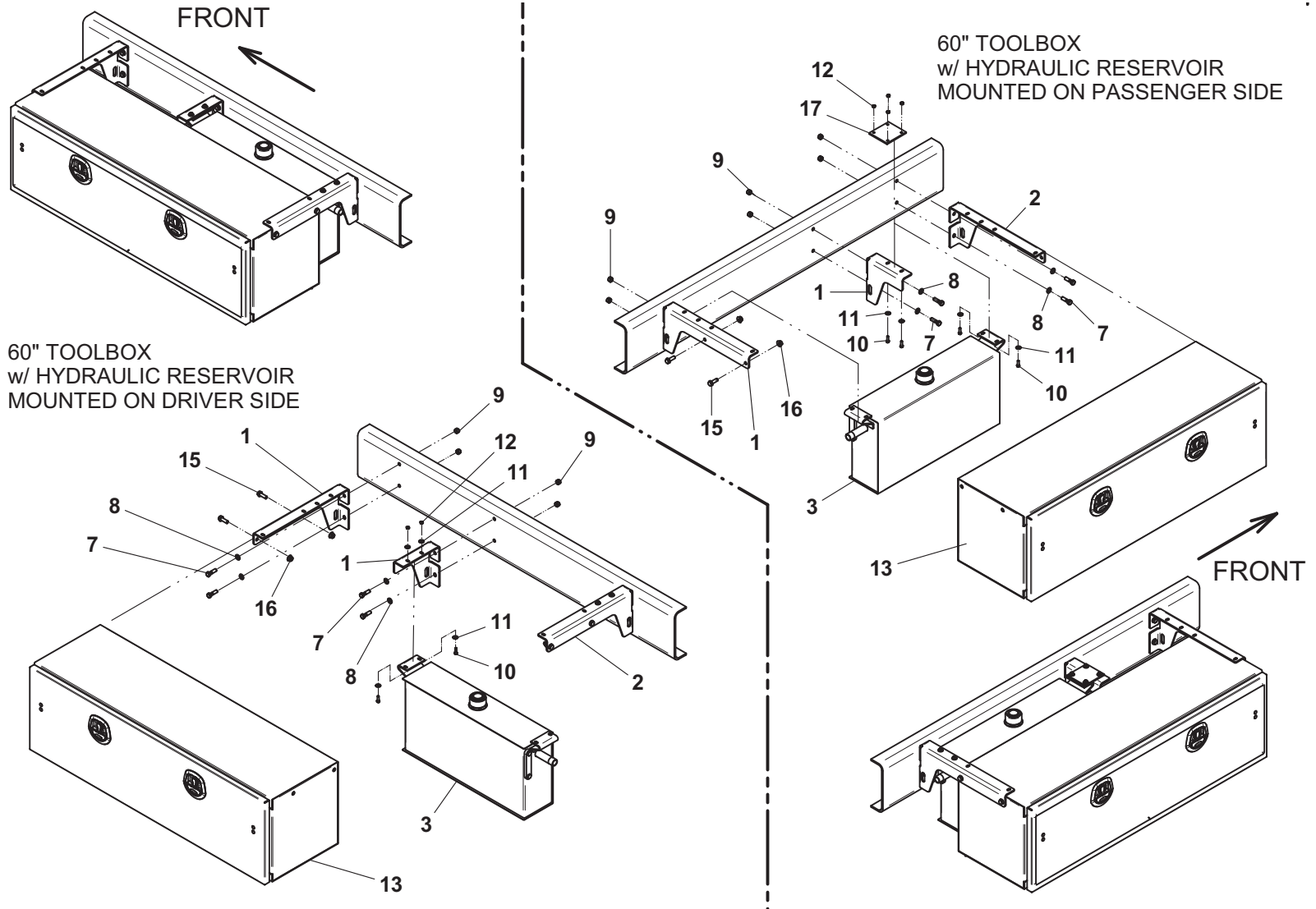

Item #14, Toolbox Rubber Pad, not shown

HYDRAULIC RESERVOIR AND TOOLBOX / BASKET

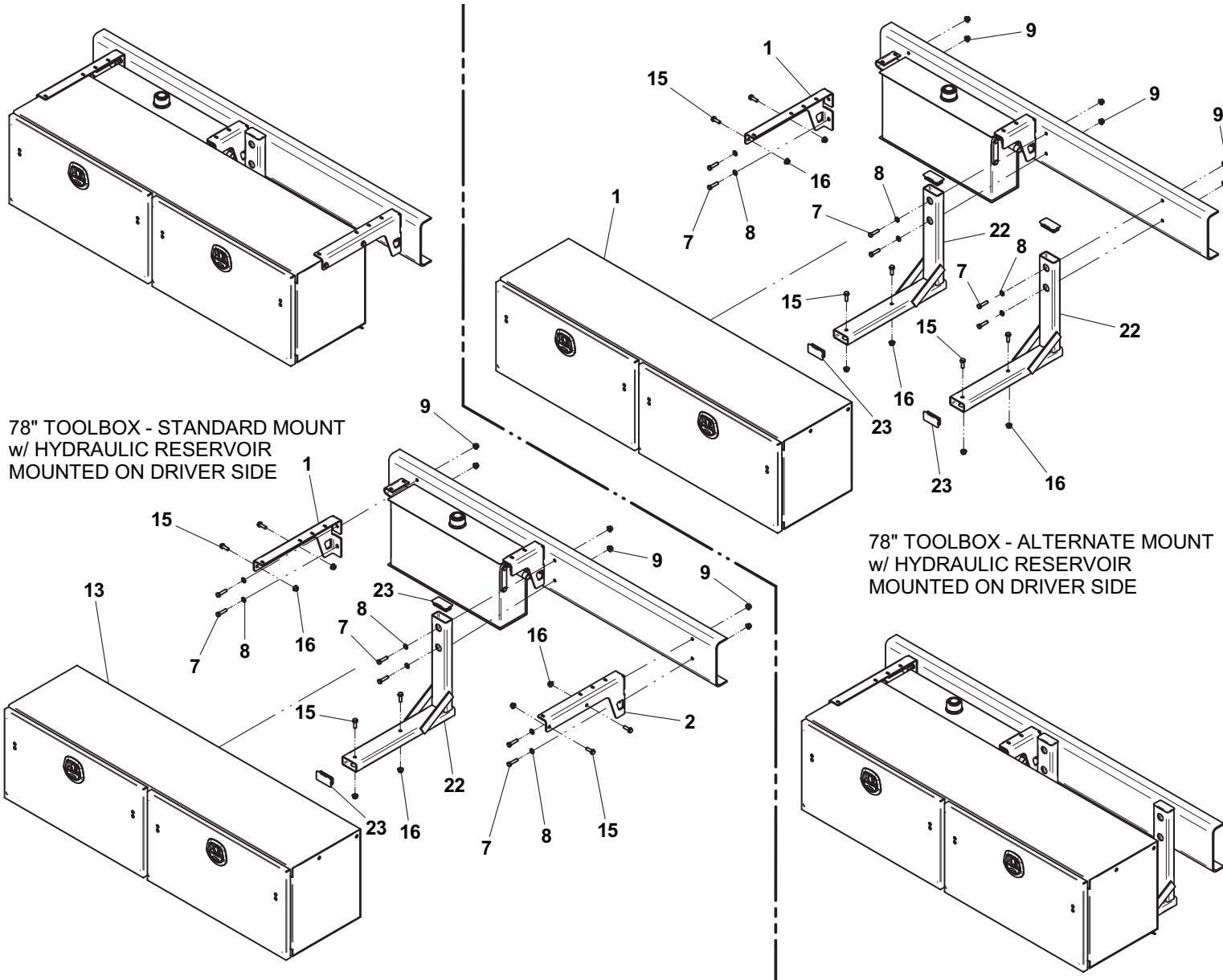

78" TOOLBOX - STANDARD MOUNT
w/ HYDRAULIC RESERVOIR
MOUNTED ON DRIVER SIDE

78" TOOLBOX - ALTERNATE MOUNT
w/ HYDRAULIC RESERVOIR
MOUNTED ON DRIVER SIDE

HYDRAULIC RESERVOIR AND TOOLBOX / BASKET

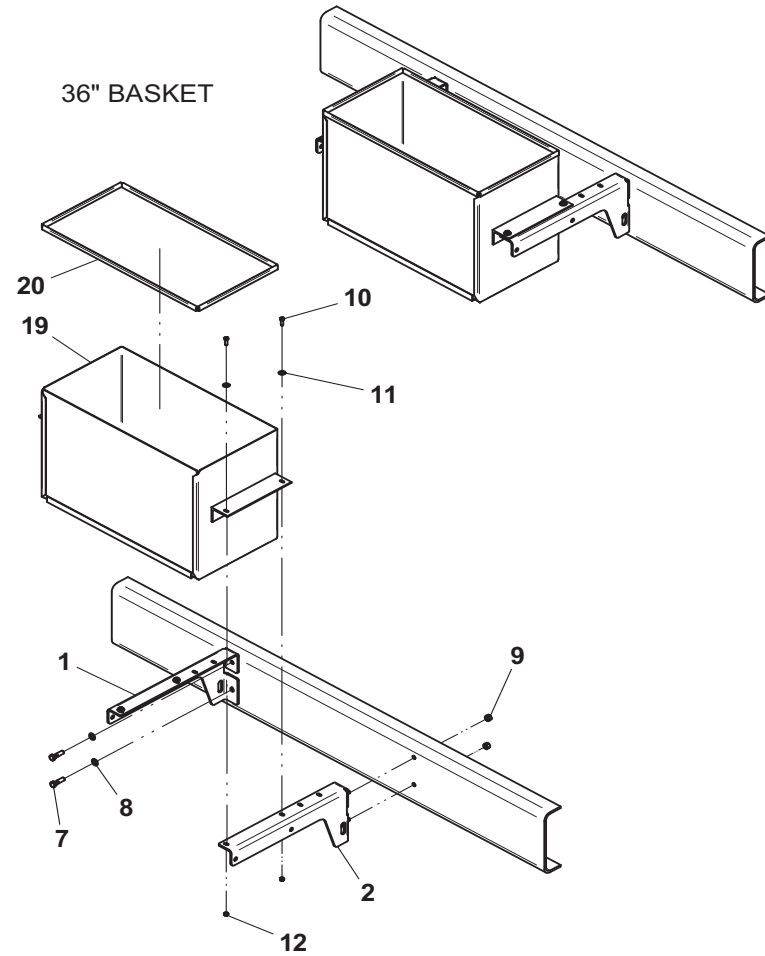
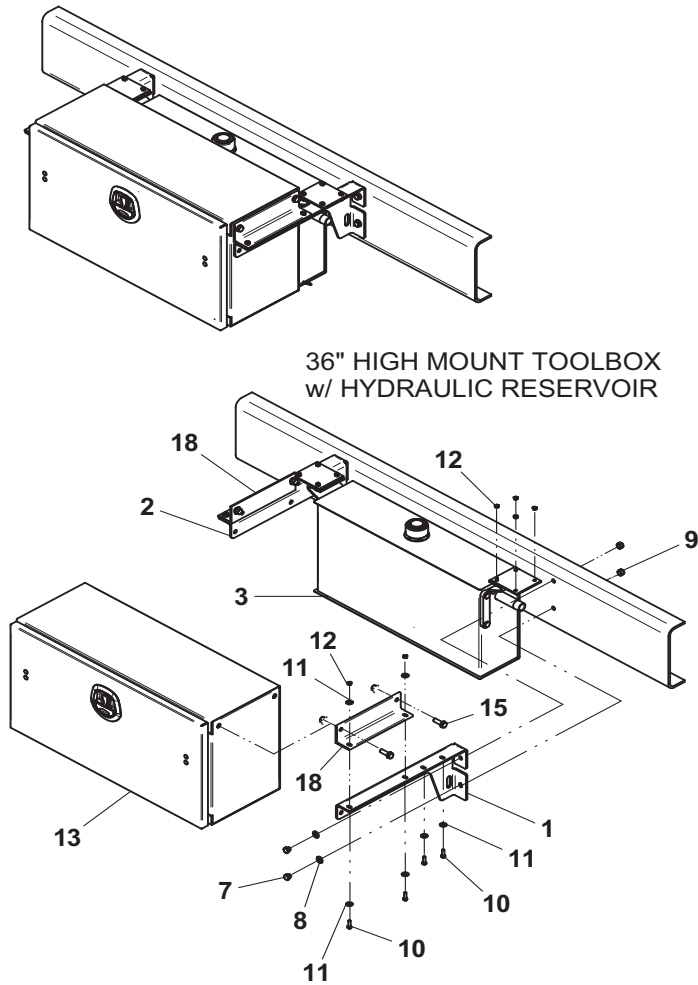

Items #14, Toolbox Rubber Pad and #21, Stainless Cover for Basket, not shown

THIS PAGE INTENTIONALLY LEFT BLANK

TOOLBOX

ITEM	PART NO.	DESCRIPTION	QTY	ITEM	PART NO.	DESCRIPTION	QTY
1	3899000125	Toolbox Weld (36" toolbox)	1			<i>Toolbox Door Assembly Components</i>	
	3899000126	Toolbox Weld (36" narrow toolbox)				<i>(per door)</i>	
	3899000128	Toolbox Weld (60" toolbox)	1	101	4706005020	Toolbox Door (36" toolbox)	1
	3899000127	Toolbox Weld (48" toolbox)	1		4706005021	Toolbox Door (48" toolbox)	1
	3899000173	Toolbox Weld (78" toolbox)	1		4706005022	Toolbox Door (60" toolbox)	1
2	4679000256	Rubber Pad (36" toolbox)	1		4706006234	Toolbox Door (78" toolbox)	1
	4679000257	Rubber Pad (36" narrow toolbox)	1	102	7585000019^	Latch (36" & 78")	1
	4679000258	Rubber Pad (48" toolbox)	1		7585000019^	Latch (48" & 60")	2
	4679000259	Rubber Pad (60" toolbox)	1	103	7555000016*	Hinge (36" & 78" toolbox)	1
	4679000322	Rubber Pad (78" toolbox)	1		7555000016*	Hinge (60" toolbox)	2
3	4796000009	Gasket (36" toolbox)	1		7555000015*	Hinge (48" toolbox)	1
	4796000010	Gasket (48" toolbox)	1	104	7759000020*^	Rivet (36" & 78" toolbox)	18
	4796000011	Gasket (60" toolbox)	1		7759000020*^	Rivet (48" toolbox)	28
	4796000012	Gasket (78" toolbox)	2		7759000020*^	Rivet (60" toolbox)	36
4	9899000014	Toolbox Door Assembly (36" toolbox)	1	105	4178000599*	Bracket	2
	9899000015	Toolbox Door Assembly (48" toolbox)	1	106	7114140465*	Carriage Bolt, 0.25"-20NC x 0.50"	4
	9899000016	Toolbox Door Assembly (60" toolbox)	1	107	7660142604*	Locknut, 0.25"-20NC	4
	9899000023	Toolbox Door Assembly (78" toolbox)	1	108	7592000005^	S Link (36", 48", 60" toolbox)	4
					7592000005^	S Link (78" toolbox)	8
				109	7248000114^	Cable (36", 48" & 60" toolbox)	2
					7248000155^	Cable (78" toolbox)	4

* Also available in Toolbox Door Sub Assembly:

- 9899000020 - 36" Toolbox
- 9899000021 - 48" Toolbox
- 9899000022 - 60" Toolbox
- 9899000024 - 78" Toolbox

^ Also available in Toolbox Door Hardware Kit:

- 9577030278 - 36" Toolbox
- 9577030279 - 48" Toolbox
- 9577030280 - 60" Toolbox
- 9577030303 - 78" Toolbox

Quantities listed are for one toolbox

TOOLBOX

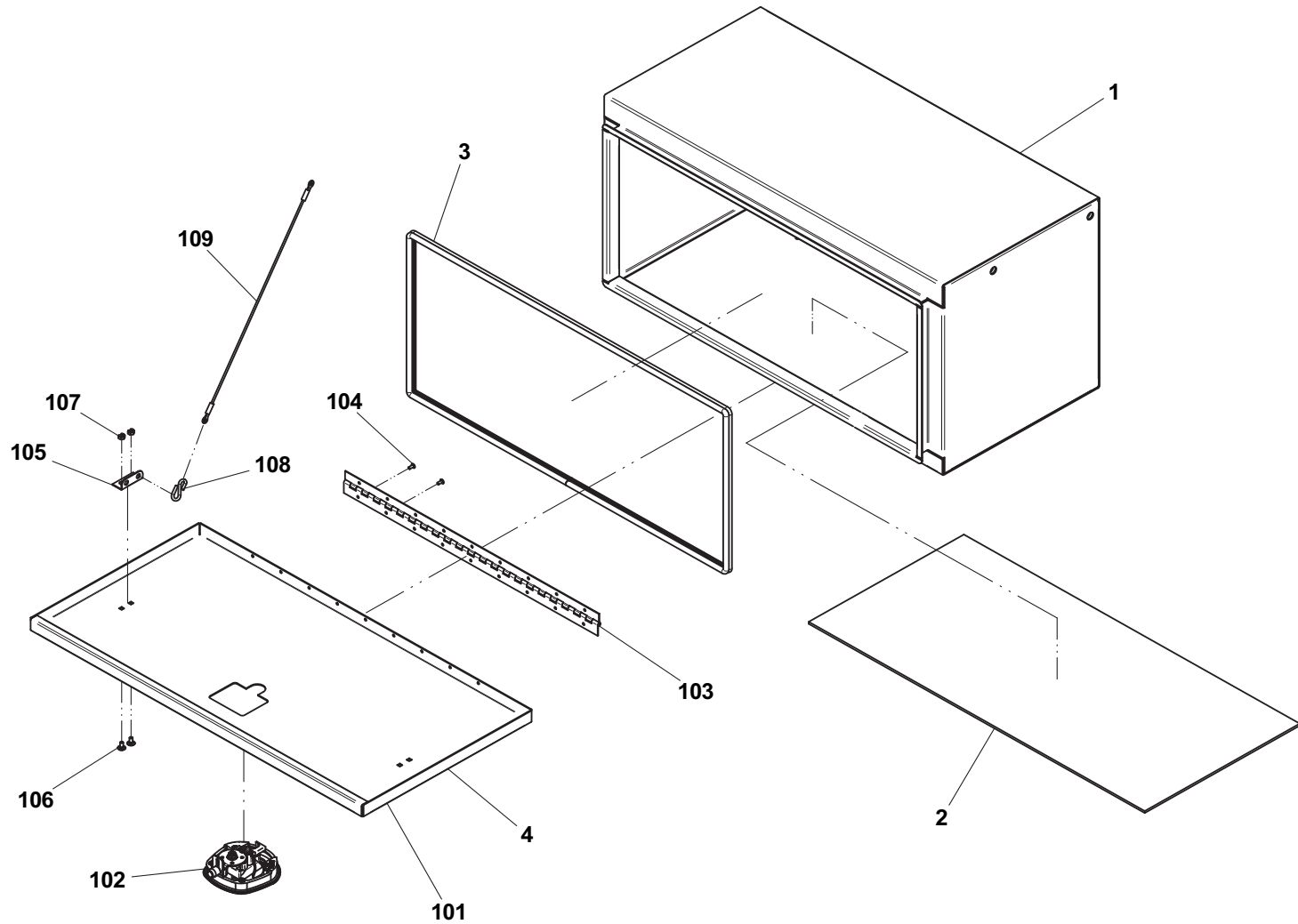

36" Toolbox shown

TOOLBOX SHELF

ITEM	PART NO.	DESCRIPTION	QTY
1	4017001403	Angle	2
2	4811000841	Shelf (36" toolbox)	1
	4811000843	Shelf (48" toolbox)	
	4811000868	Shelf (60" toolbox)	
3	7115150850	Capscrew, 0.31"-18NC x 1.00"	4
4	7950150161	Flatwasher, 0.31" ID	8
5	7660152601	Locknut, 0.31"-18NC	4

TOOLBOX SHELF

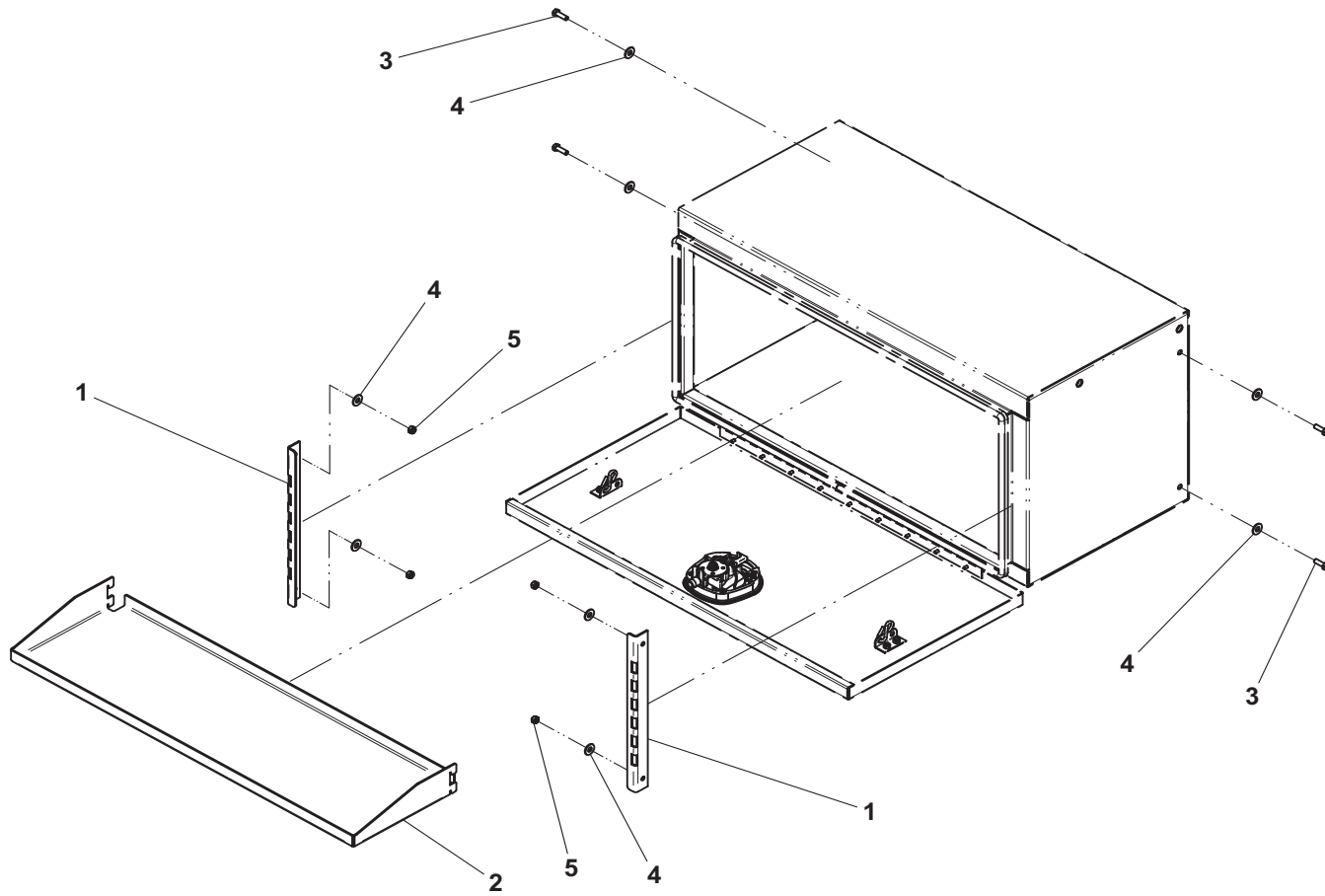

36" Toolbox shown

TOOLBOX LIGHT

ITEM	PART NO.	DESCRIPTION	QTY
1	4178000578*	Bracket	1
2	7590000273*	Dome Lamp	1
3	7870000115*	Switch	1
4	7280000007*	Wire Mount Clip	3
5	7661000047*	Panel Nut	4
6	7790100856*	Screw, #10 x 0.50"	4
7	7443000377	Fitting	1
8	7552000297	Toolbox Light Harness	1

* included in Toolbox Light Bracket Assembly

TOOLBOX LIGHT

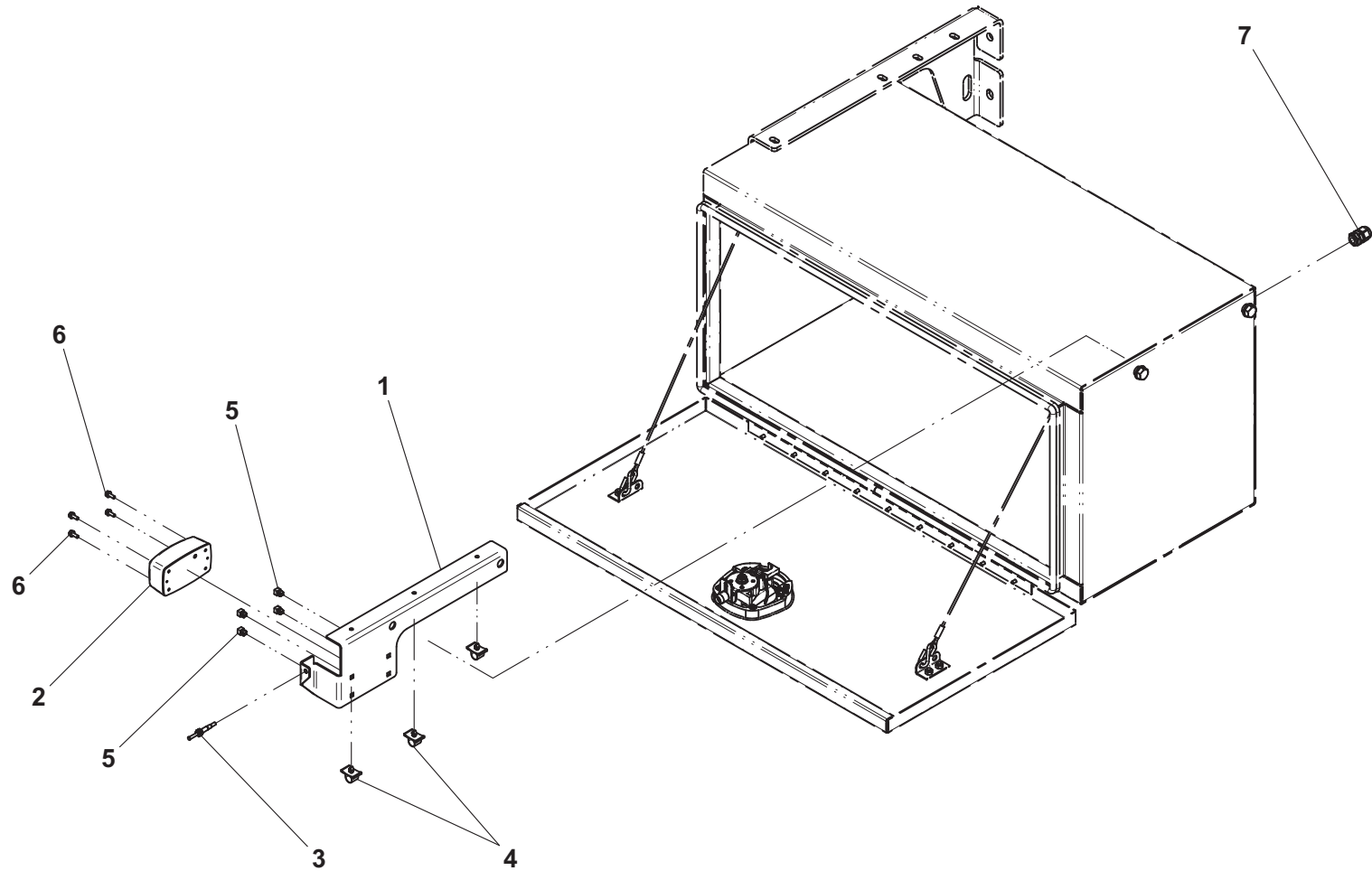

Item #8, Toolbox Light Harness, not shown
48" Toolbox Shown

TOOLBOX TOP STOWAGE TRAY AND MARKER LIGHTS

ITEM	PART NO.	DESCRIPTION	QTY
1	3811000053	Tray Weldment (36" Toolbox)	1
	3811000054	Tray Weldment (48" Toolbox)	
	3811000055	Tray Weldment (60" Toolbox)	
	3811000057	Tray Weldment (78" Toolbox)	
2	4706006216	Plate	2
3	7115160950	Capscrew, 0.38"-16NC x 1.12"	4
4	7950150161	Flat Washer, 0.38" ID	8
5	7660162601	Locknut, 0.38"-16NC	4
6	7493000009	Grommet	2
7	7493000031	Marker Light - Amber (LED)	2
8	7493000031	Grommet	2
9	7552000451	Toolbox Light Tray Harness	1
10	7894000004	Tie Strap	6

TOOLBOX TOP STORAGE TRAY AND MARKER LIGHTS

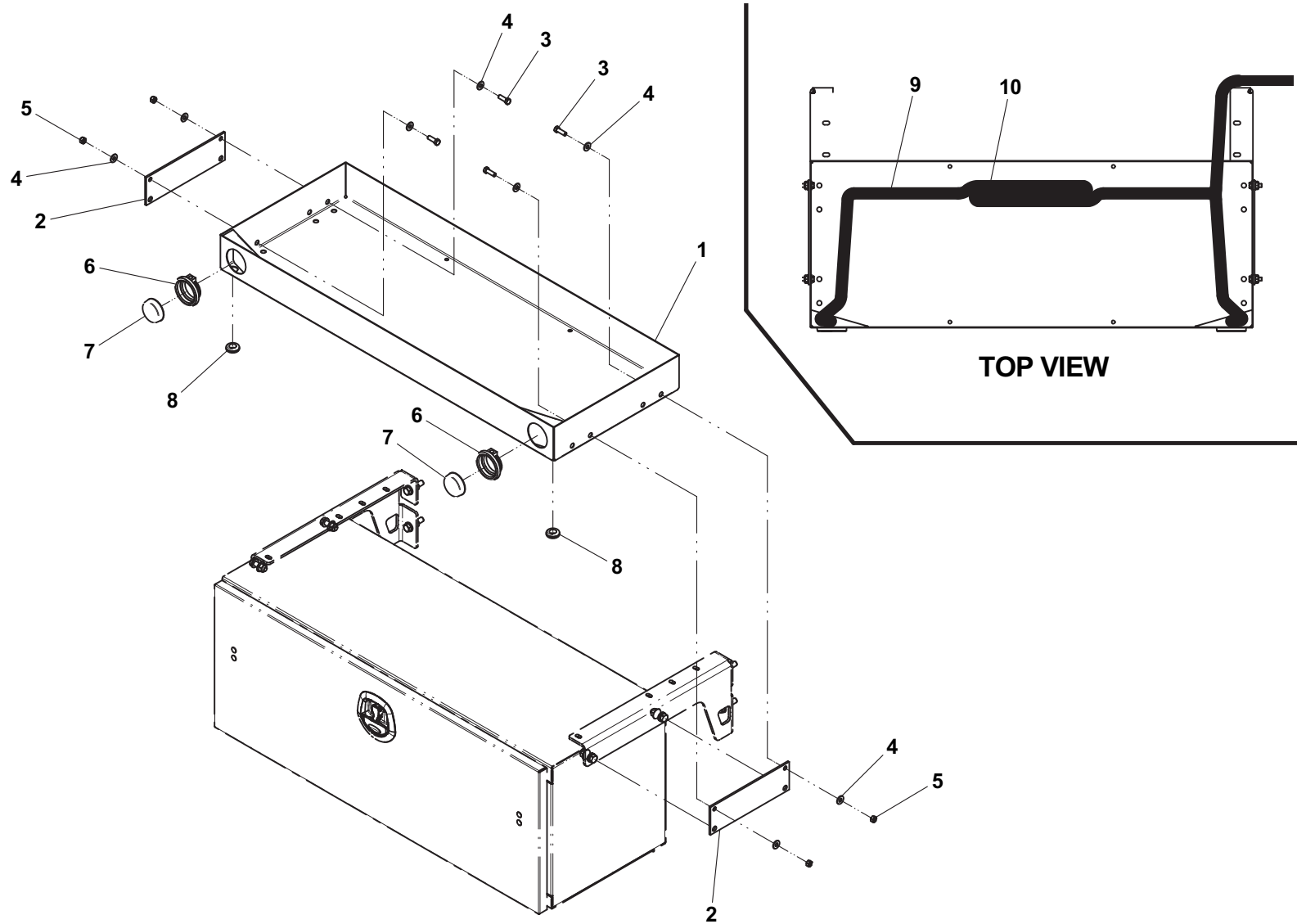

DUAL CONTROLS - 3 BANK

ITEM	PART NO.	DESCRIPTION	QTY	ITEM	PART NO.	DESCRIPTION	QTY
1	4263000431	Channel	1	29	7949000054	Washer, 0.34" ID	8
2	7950180161	Flatwasher, 0.50" ID	4	30	7330000648	Control Panel, LH	1
3	7660182601	Locknut, 0.50"-13NC	4	31	7330000649	Control Panel, RH	1
4	4263000430	Channel	1	32	7759000006	Pop Rivet	8
5	7790151253	Screw, 0.31"-18NC x 0.75"	12	33	7590000087	Lamp	2
6	3935000115	Control Valve	1	34	7791060872	Screw, #6 x 0.50"	4
7	7111161050	Capscrew, 0.38"-16NC x 1.25"	4	35	7280000007	Wire Clip	11
8	7950160161	Flatwasher, 0.38" ID	4	36	4606000217	Lug	4
9	7660162601	Locknut, 0.38"-16NC	4	37	7560000007	Control Hood, RH	1
10	4763000280	Control Rod	3	38	7470000023	Gauge	1
11	4763000279	Control Rod	3	39	7661000057	Jam Nut, M5	2
12	7690101200	Clevis Pin	3				
13	7691000056	Cotter Pin	3				
14	7115150850	Capscrew, 0.31"-18NC x 1.00"	9				
15	7949000011	Flatwasher, 0.31" ID	9				
16	4831000069	Spacer	9				
17	7660152601	Locknut, 0.31"-18NC	17				
18	Not Required						
19	7115150664	Carriage Bolt, 0.31"-18NC x 0.75"	8				
20	7950150000	Washer, 0.31" ID	8				
21	7691000064	Pin	2				
22	7754000009	Retaining Ring	4				
23	7551000018	Control Handle	2				
24	7551000020	Control Handle	2				
25	7551000021	Control Handle	2				
26	4211000001	Bushing	4				
27	7950220141	Flatwasher, 0.75" ID	4				
28	7560000008	Control Hood, LH	1				

DUAL CONTROLS - 3 BANK

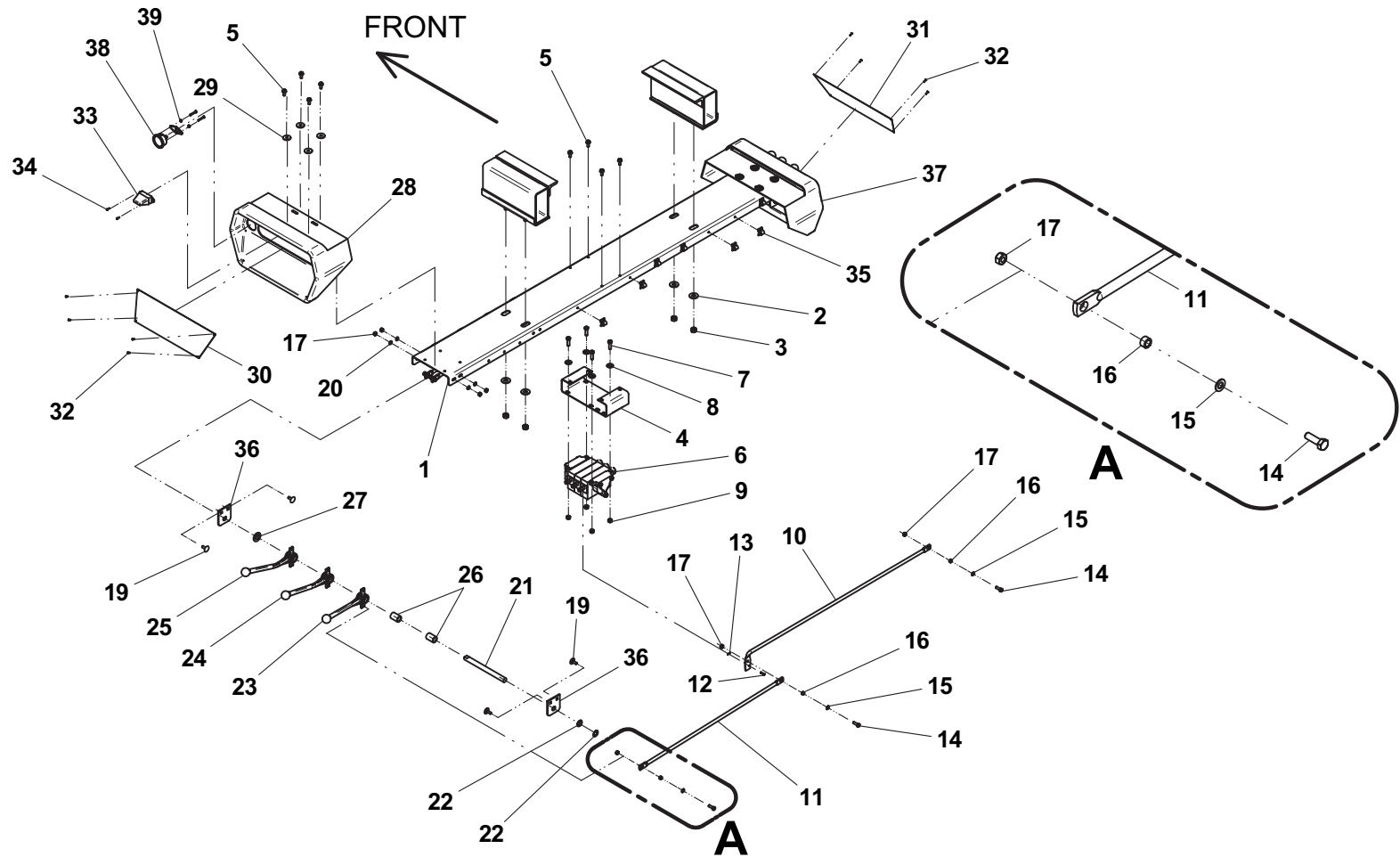

DUAL CONTROLS - 4 BANK

ITEM	PART NO.	DESCRIPTION	QTY	ITEM	PART NO.	DESCRIPTION	QTY
1	4263000431	Channel	1	30	7330000650	Control Panel, LH (stabilizer)	1
2	7950180161	Flatwasher, 0.50" ID	4	31	7330000651	Control Panel, RH (stabilizer)	1
3	7660182601	Locknut, 0.50"-13NC	4	32	7759000006	Pop Rivet	8
4	4263000430	Channel	1	33	7590000087	Lamp	2
5	7790151253	Screw, 0.31"-18NC x 0.75"	12	34	7791060872	Screw, #6 x 0.50"	4
6	3935000116	Control Valve	1	35	7280000007	Wire Clip	11
7	7111161050	Capscrew, 0.38"-16NC x 1.25"	4	36	4606000217	Lug	4
8	7950160161	Flatwasher, 0.38" ID	4	37	7560000007	Control Hood, RH	1
9	7660162601	Locknut, 0.38"-16NC	4	38	7470000023	Gauge	1
10	4763000280	Control Rod	4	39	7661000057	Jam Nut, M5	2
11	4763000279	Control Rod	4				
12	7690101200	Clevis Pin	4				
13	7691000056	Cotter Pin	4				
14	7115150850	Capscrew, 0.31"-18NC x 1.00"	12				
15	7949000011	Flatwasher, 0.31" ID	12				
16	4831000069	Spacer	12				
17	7660152601	Locknut, 0.31"-18NC	20				
18	Not Required						
19	7115150664	Carriage Bolt, 0.31"-18NC x 0.75"	8				
20	7950150000	Washer, 0.31" ID	8				
21	7691000064	Pin	2				
22	7754000009	Retaining Ring	4				
23	7551000018	Control Handle	2				
24	7551000020	Control Handle	4				
25	7551000021	Control Handle	2				
26	4211000001	Bushing	2				
27	7950220141	Flatwasher, 0.75" ID	2				
28	7560000008	Control Hood, LH	1				
29	7949000054	Washer, 0.34" ID	8				

DUAL CONTROLS - 4 BANK

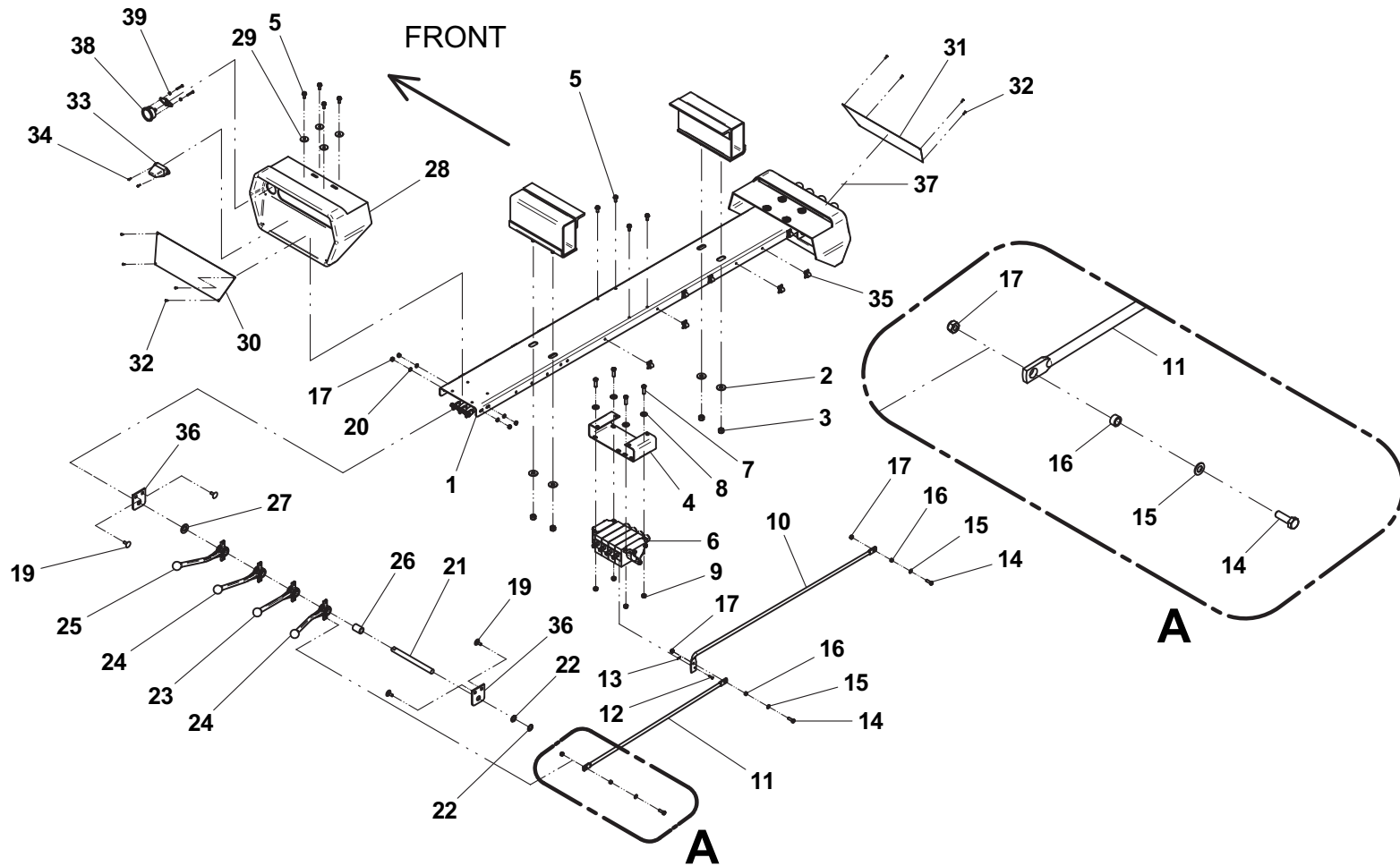

DUAL CONTROLS - 5 BANK

ITEM	PART NO.	DESCRIPTION	QTY	ITEM	PART NO.	DESCRIPTION	QTY
1	4263000431	Channel - Standard	1	29	7330000648	Control Panel, LH	1
	4263000776	Channel - Galvanized		30	7330000649	Control Panel, RH	1
2	7950180161	Flatwasher, 0.50" ID	4	31	7759000006	Pop Rivet	8
3	7660182601	Locknut, 0.50"-13NC	4	32	7590000087	Lamp	2
4	4263000430	Channel - Standard	1	33	7791060872	Screw, #6 x 0.50"	4
	4263000622	Channel - Galvanized		34	7280000007	Wire Clip	11
5	7790151253	Screw, 0.31"-18NC x 0.75"	12	35	4606000217	Lug	4
6	3935000117	Control Valve	1	36	7560000007	Control Hood, RH	1
7	7111161050	Capscrew, 0.38"-16NC x 1.25"	4	37	7470000023	Gauge	1
8	7950160161	Flatwasher, 0.38" ID	4	38	7661000057	Jam Nut, M5	2
9	7660162601	Locknut, 0.38"-16NC	4				
10	4763000280	Control Rod	5				
11	4763000279	Control Rod	5				
12	7690101200	Clevis Pin	5				
13	7691000056	Cotter Pin	5				
14	7115150850	Capscrew, 0.31"-18NC x 1.00"	15				
15	7949000011	Flatwasher, 0.31" ID	15				
16	4831000069	Spacer	15				
17	7660152601	Locknut, 0.31"-18NC	23				
18	Not Required						
19	7115150664	Carriage Bolt, 0.31"-18NC x 0.75"	8				
20	7950150000	Washer, 0.31" ID	8				
21	7691000064	Pin	2				
22	7754000009	Retaining Ring	4				
23	7551000018	Control Handle	2				
24	7551000020	Control Handle	4				
25	7551000021	Control Handle	4				
26	7950220141	Flatwasher, 0.75" ID	2				
27	7560000008	Control Hood, LH	1				
28	7949000054	Washer, 0.34" ID	8				

DUAL CONTROLS - 5 BANK

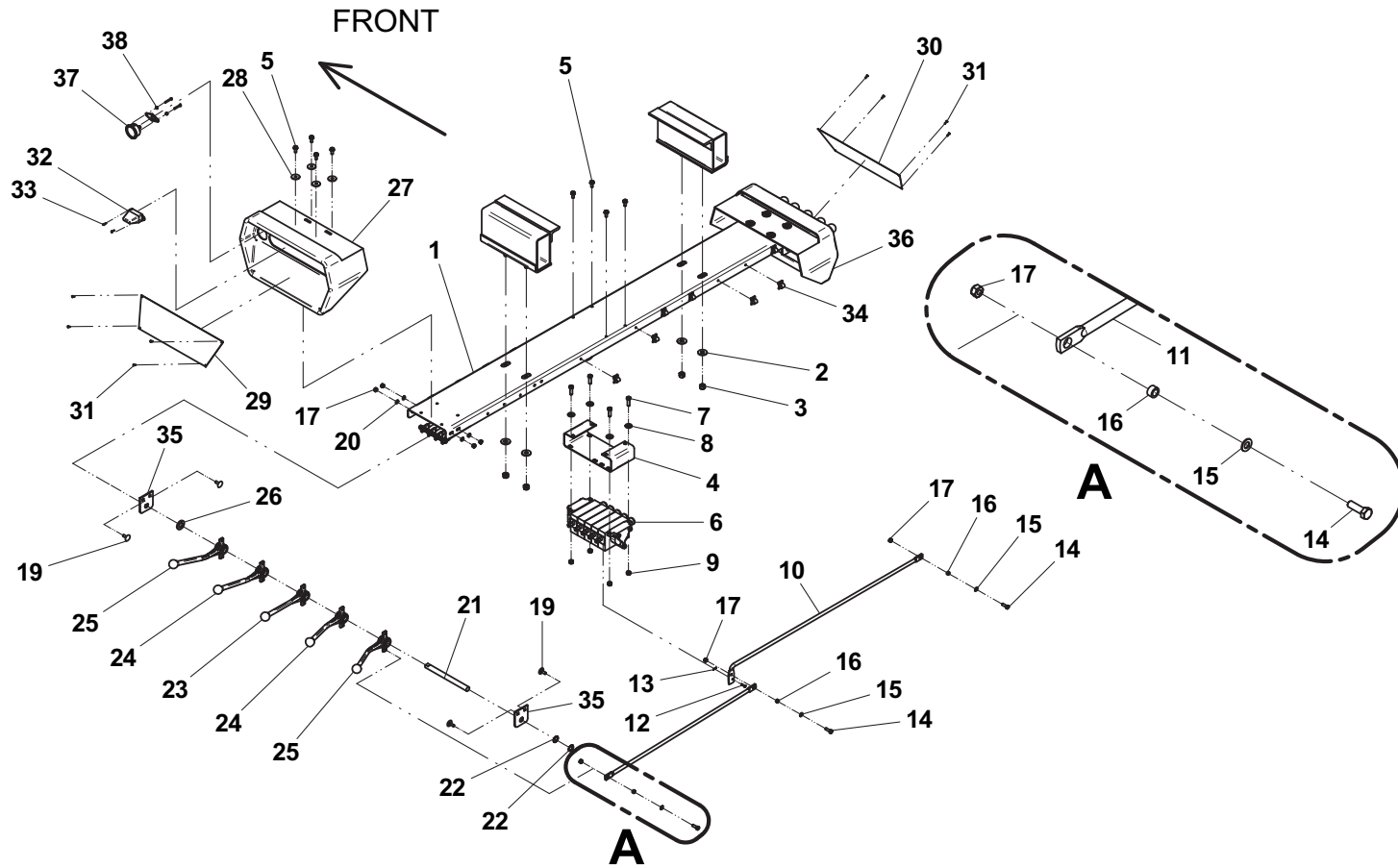

HYDRAULIC COMPONENTS - STANDARD

ITEM	PART NO.	DESCRIPTION	QTY	ITEM	PART NO.	DESCRIPTION	QTY
1	See Note 1	PTO	1	31	4567430133	Hose Assembly	2
2	7724000126	Pump	1	32	7431000001^	Filter Element	1
3	7115181050	Capscrew	2	33	7445040443	Adapter	1
4	7950180000	Lockwasher	2	34	4567122039*	Hose Assembly	1
5	7445081643	Adapter	1	35	7274000063	P-Clamp	1
6	7443000023	Elbow	1	36	7115140650	Capscrew, 0.25"-20NC x 0.75"	1
7	7443000124	Adapter	1	37	7950140141	Flatwasher, 0.25" ID	1
8	See Note 1	Supply Hose	1	38	7660142601	Locknut, .025"-20NC	1
9	7443000013	Nipple	1	39	7912000349	Tube Assembly	4
10	7274000002	Clamp	2	40	7274000064	Clamp	6
11	7430000003	Filter Assembly	1	41	3314000056	Coverplate	2
12	7470000002	Gauge	1	42	7115150450	Capscrew, 0.31"-18NC x 0.50"	6
13	7443000319	Fitting	1	43	7950160141	Flatwasher, 0.38" ID	6
14	7274000080	Clamp	2				
15	See Note 1	Pressure Hose Assembly	1				
16	See Note 1	Return Hose	1				
17	7443000446	Adapter	1				
18	7445081045	Elbow	3				
19	7445060843	Adapter	4				
20	7445080843	Adapter	2				
21	4567123051*	Hose Assembly	1				
22	4567122024*	Hose Assembly	1				
23	4567122019	Hose Assembly	2				
24	7935000306	Dual Counterbalance Valve	1				
25	7445060643	Adapter	4				
26	4570000379*	Hose Assembly	4				
27	4570000376*	Hose Assembly	4				
28	7445060645	Elbow	5				
29	4569432122	Hose Assembly	1				
30	4569433122	Hose Assembly	1				

* included in Hose Kit, P/N 4577000013

^ also available in Filter Assembly, P/N 7430000003

Note 1: Varies depending on chassis, transmission , PTO type & deck length.
Consult factory for part numbers.

HYDRAULIC COMPONENTS - STANDARD

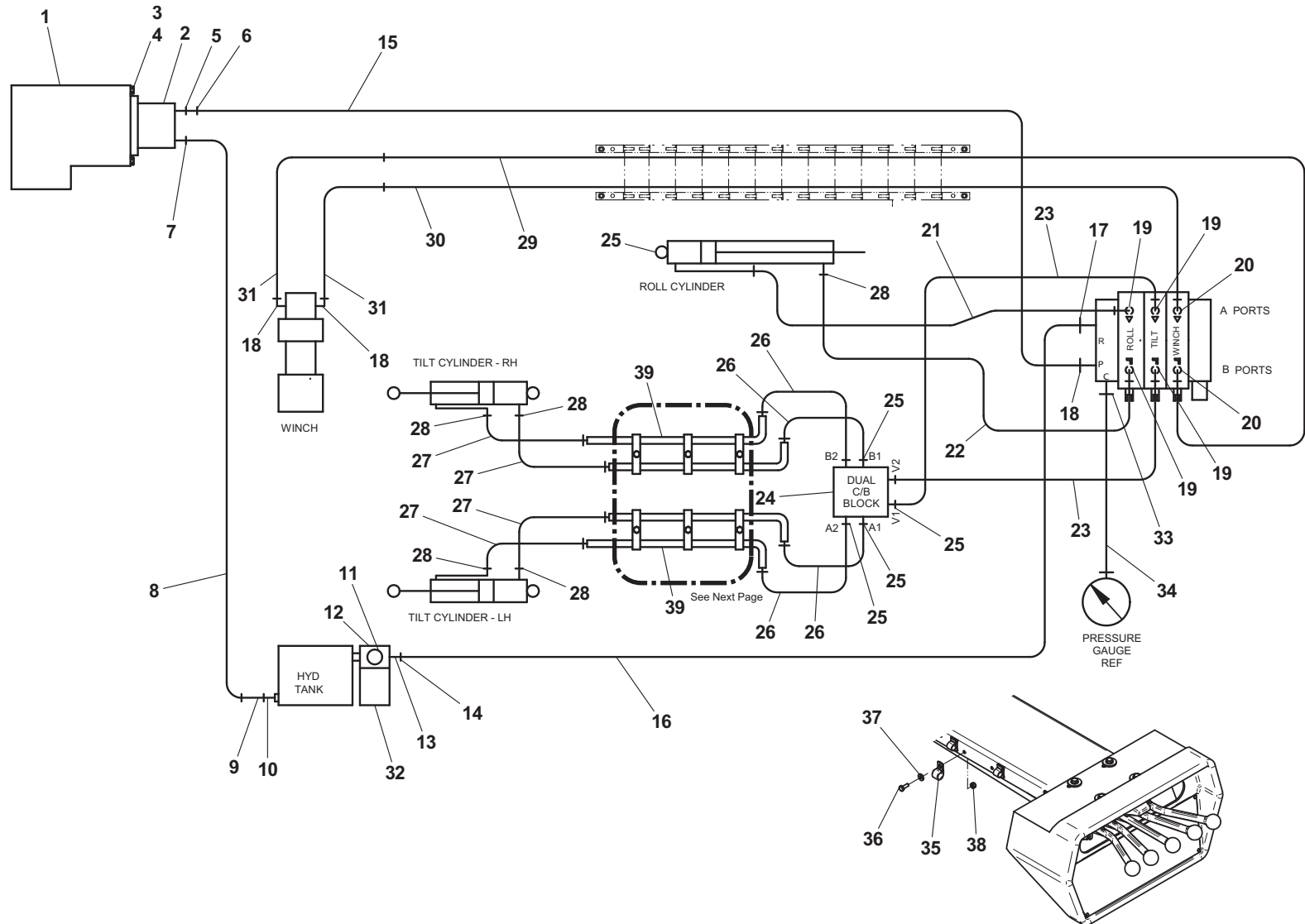

CLAMP FOR PRESSURE GAUGE HOSE, ITEM #34

HYDRAULIC COMPONENTS - STANDARD

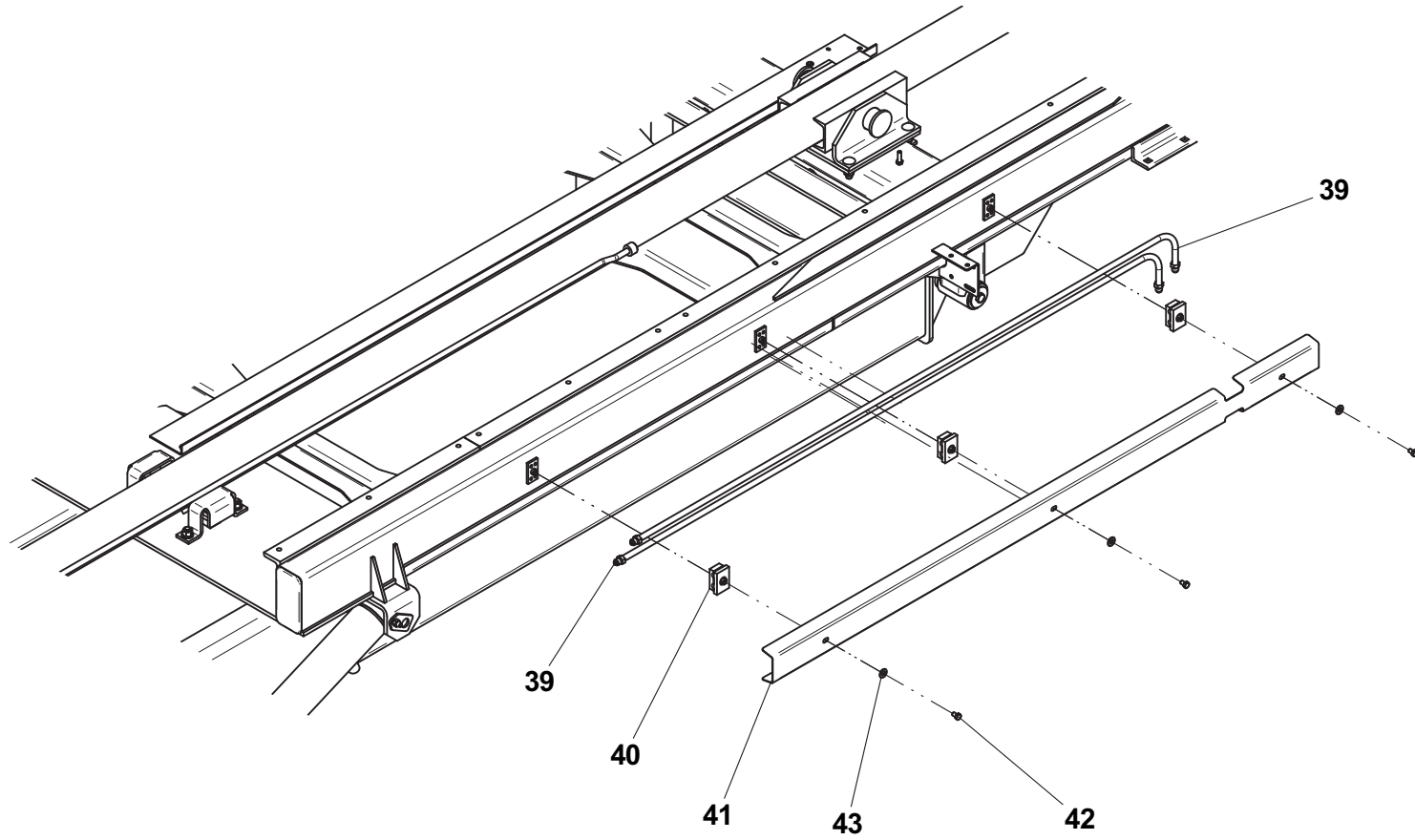

THIS PAGE INTENTIONALLY LEFT BLANK

HYDRAULIC COMPONENTS - STANDARD (HOSE TRACK)

ITEM	PART NO.	DESCRIPTION	QTY
1	7904000001	Hose Track	1
2	4706003038	Plate	1
3	7114101618	Capscrew	4
4	7660102604	Locknut, #10-24NC	4
5	7274000038	Clamp	4
6	7274000039	Clamp Cover	2
7	7115151650	Capscrew, 0.31"-18NC x 2.00"	2
8	7950150161	Flatwasher, 0.31" ID	4
9	7660152601	Locknut, 0.31"-18NC	8
10	7894000004	Tie Strap	10
11	7935000306	Counterbalance Valve	1
12	7115151850	Capscrew, 0.31"-18NC x 2.50"	2
13	7274000066	Double Clamp	4
14	7280000013	Clip	*

* Quantity varies depending on deck length and deck type.

HYDRAULIC COMPONENTS - STANDARD (HOSE TRACK)

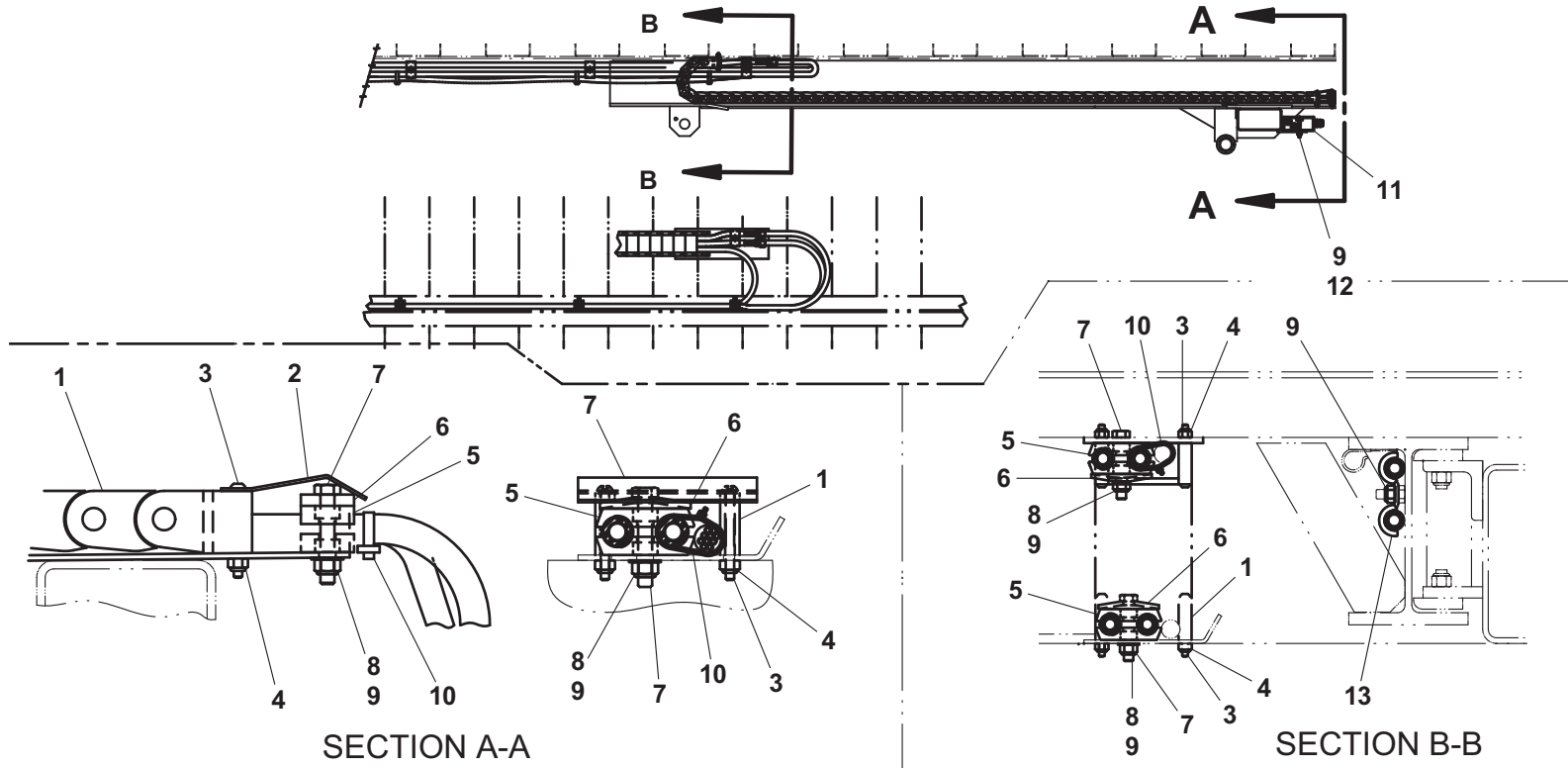

SECTION A-A

SECTION B-B



STEEL & WOOD
DECK MAIN BEAM

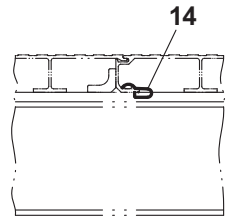

ALUMINUM DECK
EXTRUSION

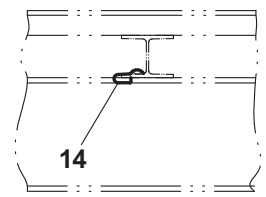

WOOD DECK
CROSSMEMBER

HYDRAULIC COMPONENTS - HOSE ROUTING / MOUNTING (FORD, GM & IHC)

ITEM	PART NO.	DESCRIPTION	QTY
1	7274000076	Cast Frame Clamp	*
2	7785152420	Set Screw, 0.31"-18NC x 1.50"	*
3	7660152601	Locknut, 0.31"-18NC	*
4	7115151050	Capscrew, 0.31"-18NC x 1.25"	*
5	7950150161	Flatwasher, 0.31" ID	*
6	7274000040	Clamp	*
7	7274000041	Clamp	*
8	7274000042	Clamp	*
9	4706003844	Plate	*
10	7115151064	Carriage Bolt, 0.31"-18NC x 1.25"	*

* Quantity varies depending on deck length and deck type

HYDRAULIC COMPONENTS - HOSE ROUTING / MOUNTING (FORD, GM & IHC)

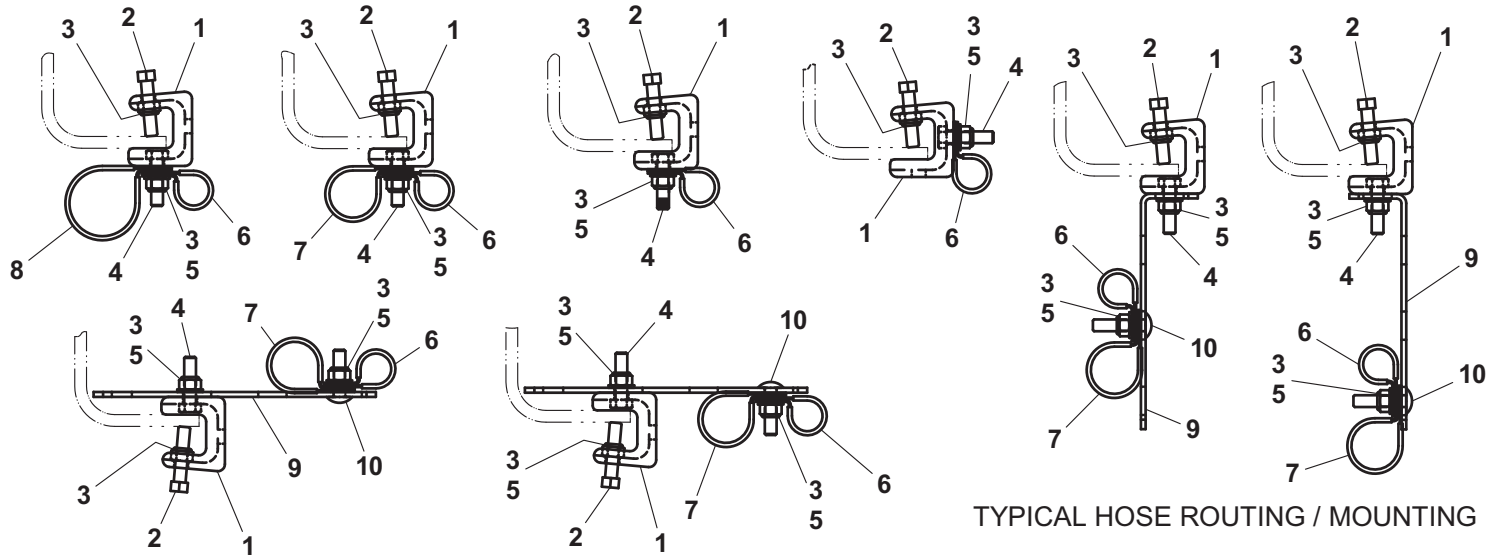
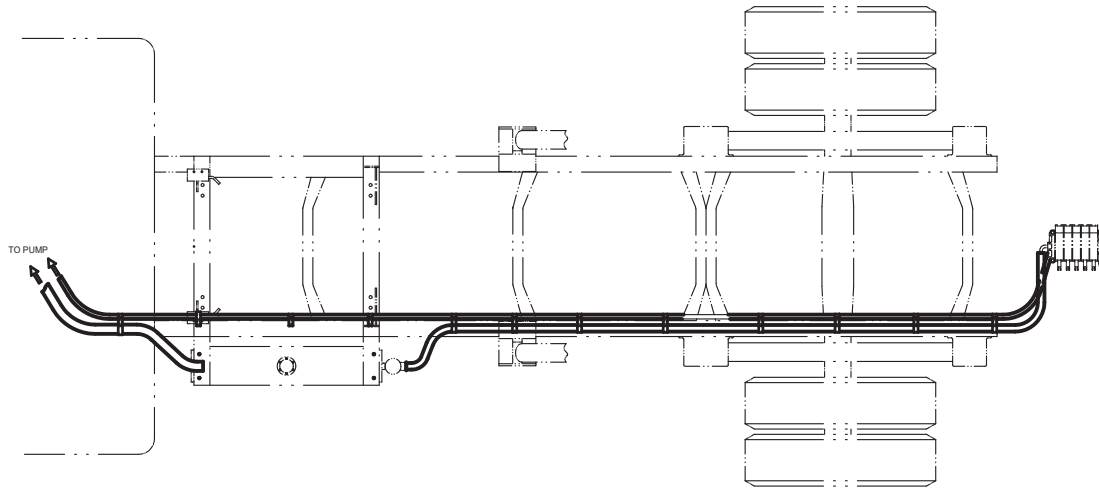

HYDRAULIC COMPONENTS - IRL WHEEL LIFT WITH MANUAL GRIDS

ITEM	PART NO.	DESCRIPTION	QTY
1	7443000129	Reducer	2
2	7445060648	Tee	4
3	4567123045	Hose Assembly	2
4	4567122043	Hose Assembly	2
5	7935000305	Counterbalance Valve	2
6	7445060645	Elbow	4
7	4567122014	Hose Assembly	2
8	7443040843	Adapter	2
9	4567110034	Hose Assembly	2
10	7445040446	Elbow	2

HYDRAULIC COMPONENTS - IRL WHEEL LIFT WITH MANUAL GRIDS

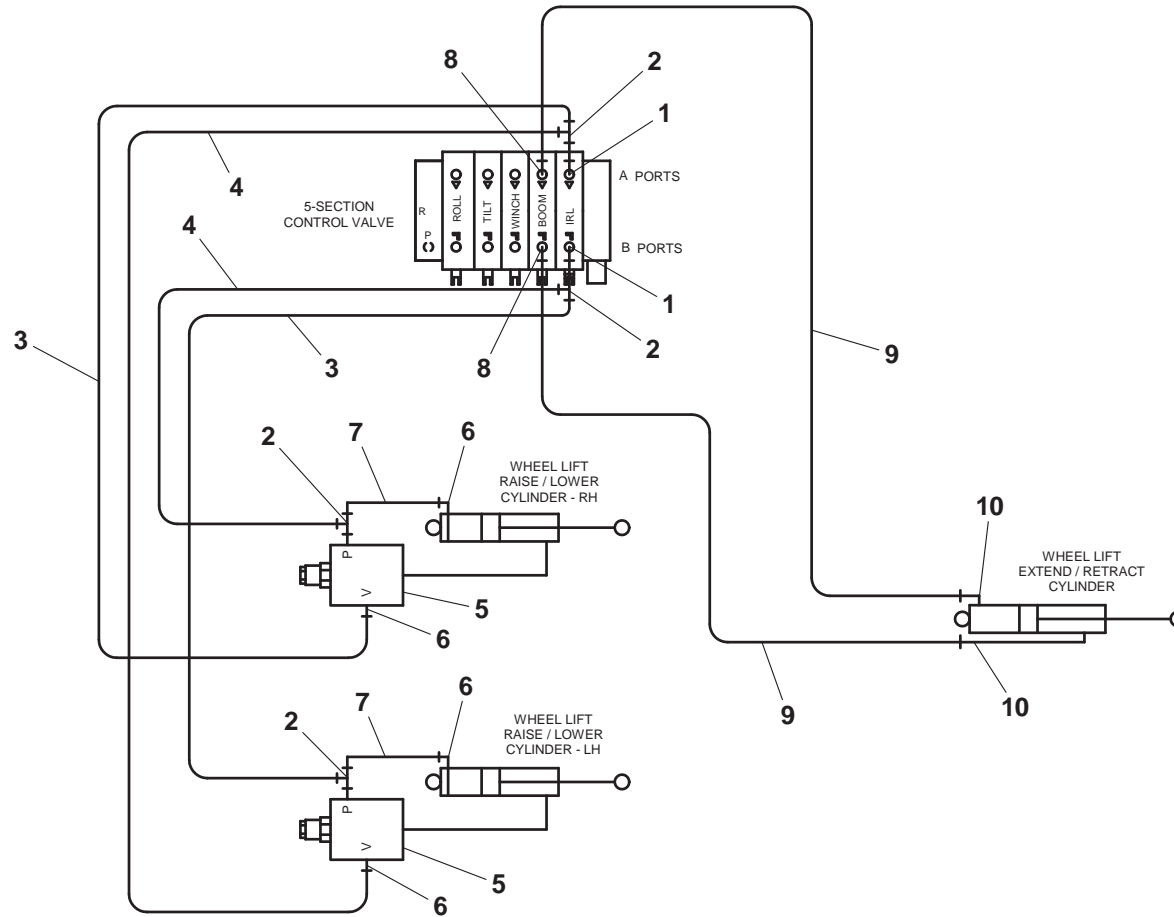

HYDRAULIC COMPONENTS - HYDRAULIC REAR DOCK STABILIZER

ITEM	PART NO.	DESCRIPTION	QTY
1	7445060843	Adapter	2
2	4567122035	Hose Assembly	2
3	7445060637	Tee	2
4	4567120019	Hose Assembly	4
5	7445060645	Elbow	4

HYDRAULIC COMPONENTS - HYDRAULIC REAR DOCK STABILIZER

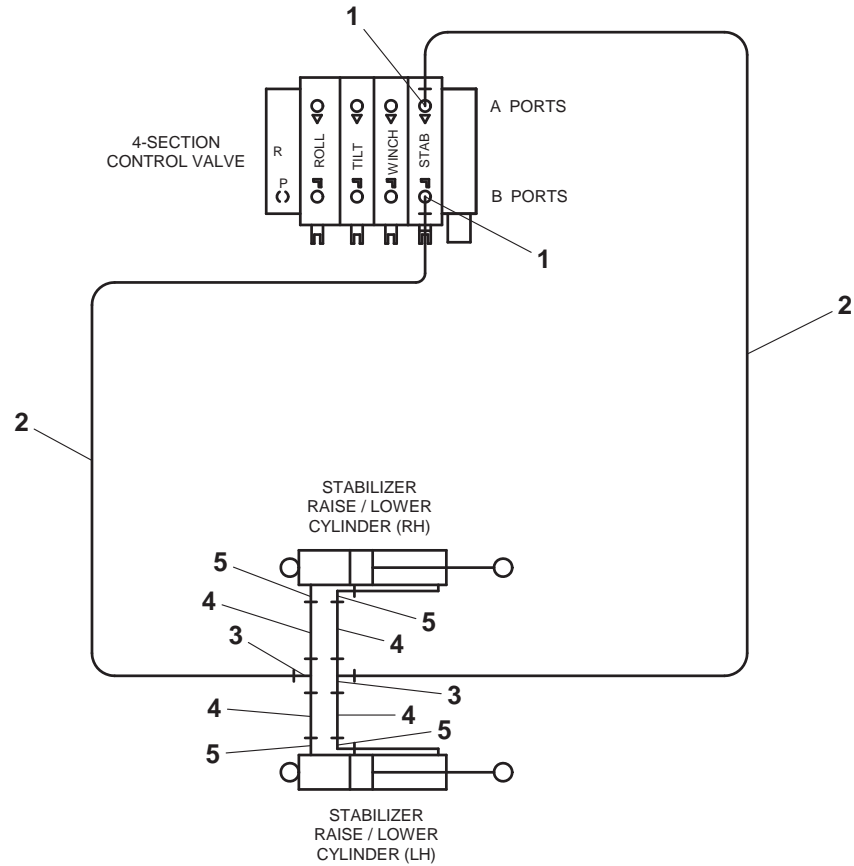

HYDRAULIC COMPONENTS - STABILIZER W/ REESE HITCH RECEIVER OR PINTLE HITCH MTG PLT

ITEM	PART NO.	DESCRIPTION	QTY
1	7445060845	Elbow	2
2	7443000030	Tee	2
3	4567123050	Hose Assembly	2
4	4567122046	Hose Assembly	2
5	7935000305	Counterbalance Valve	2
6	7445060648	Tee	2
7	7445060645	Elbow	4
8	4567122014	Hose Assembly	2

HYDRAULIC COMPONENTS - STABILIZER W/ REESE HITCH RECEIVER OR PINTLE HITCH MTG PLT

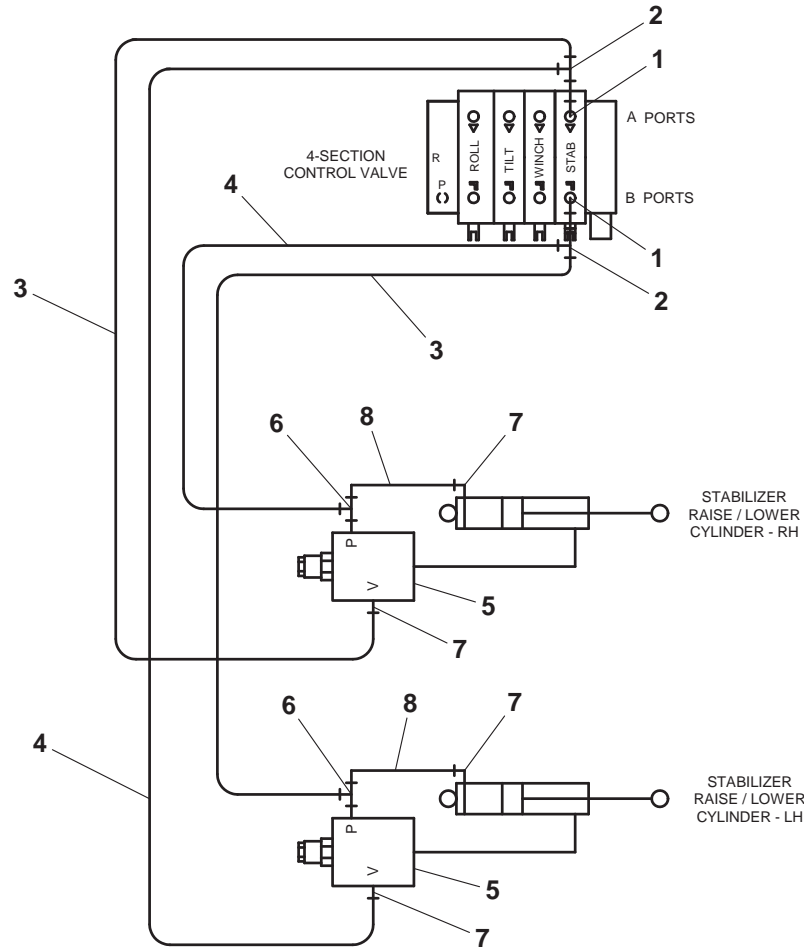

ELECTRICAL COMPONENTS - STANDARD W/ DECK MOUNTED HEADBOARD

ITEM	PART NO.	DESCRIPTION	QTY
1	7552000098	Subframe to Deck Harness	1
2	7552000074	Subframe to Cab Harness	1
3	7552000135	Subframe Harness	1
4	7552000177	Deck Harness (21' deck)	1
	7552000179	Deck Harness (22' deck)	
5	7552000166	Winch Lights Harness	1
6	7552000222	Work Lights on Headboard Harness	1
7	1001129882^	Breaker Harness	1
8	7457000004^	Circuit Breaker	1
9	7790100856^	Screw, #10 x 0.50"	2
10	7345221902^	Terminal	1
11	7950100151^	Flatwasher, 0.19" ID	2
12	7280000013	Clip	*
13	7577000194	Wiring Connector Kit	1
14	4346000005	Heat Shrink Tubing - 1.50"	5

* Quantity varies depending on deck construction.

^ Only used with Jerr-dan Supplied Switch Panels.

ELECTRICAL COMPONENTS - STANDARD W/ DECK MOUNTED HEADBOARD

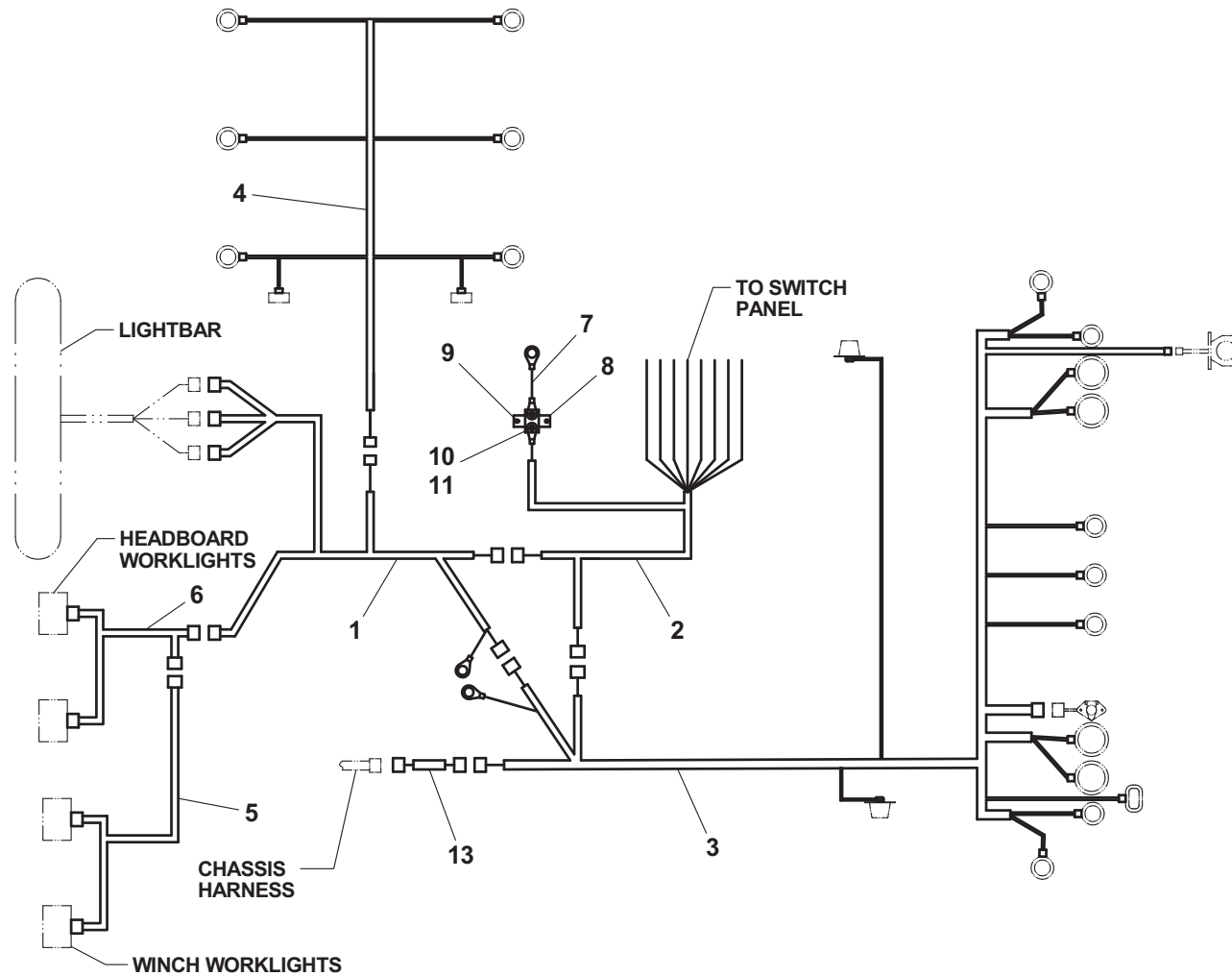

Item #12, Clip and #14, Tubing, not shown.

ELECTRICAL COMPONENTS - STANDARD W/ STATIONARY HEADBOARD

ITEM	PART NO.	DESCRIPTION	QTY
1	7552000204	Subframe to Cab Harness	1
2	7552000075	Subframe to Deck Harness	1
3	7552000135	Subframe Harness	1
4	7552000177	Deck Harness (21' deck)	1
	7552000179	Deck Harness (22' deck)	
5	7552000166	Winch Lights Harness	1
6	7345241902^	Terminal	1
7	7457000004^	Circuit Breaker	1
8	7790100856^	Screw, #10 x 0.50"	2
9	7345221902^	Terminal	2
10	7950100151^	Flatwasher, 0.19" ID	2
11	7280000013	Clip	*
12	7577000194	Wiring Connector Kit	1
13	4346000005	Heat Shrink Tubing - 1.50"	5

* Quantity varies depending on deck construction.

^ Only used with Jerr-dan Supplied Switch Panels.

ELECTRICAL COMPONENTS - STANDARD W/ STATIONARY HEADBOARD

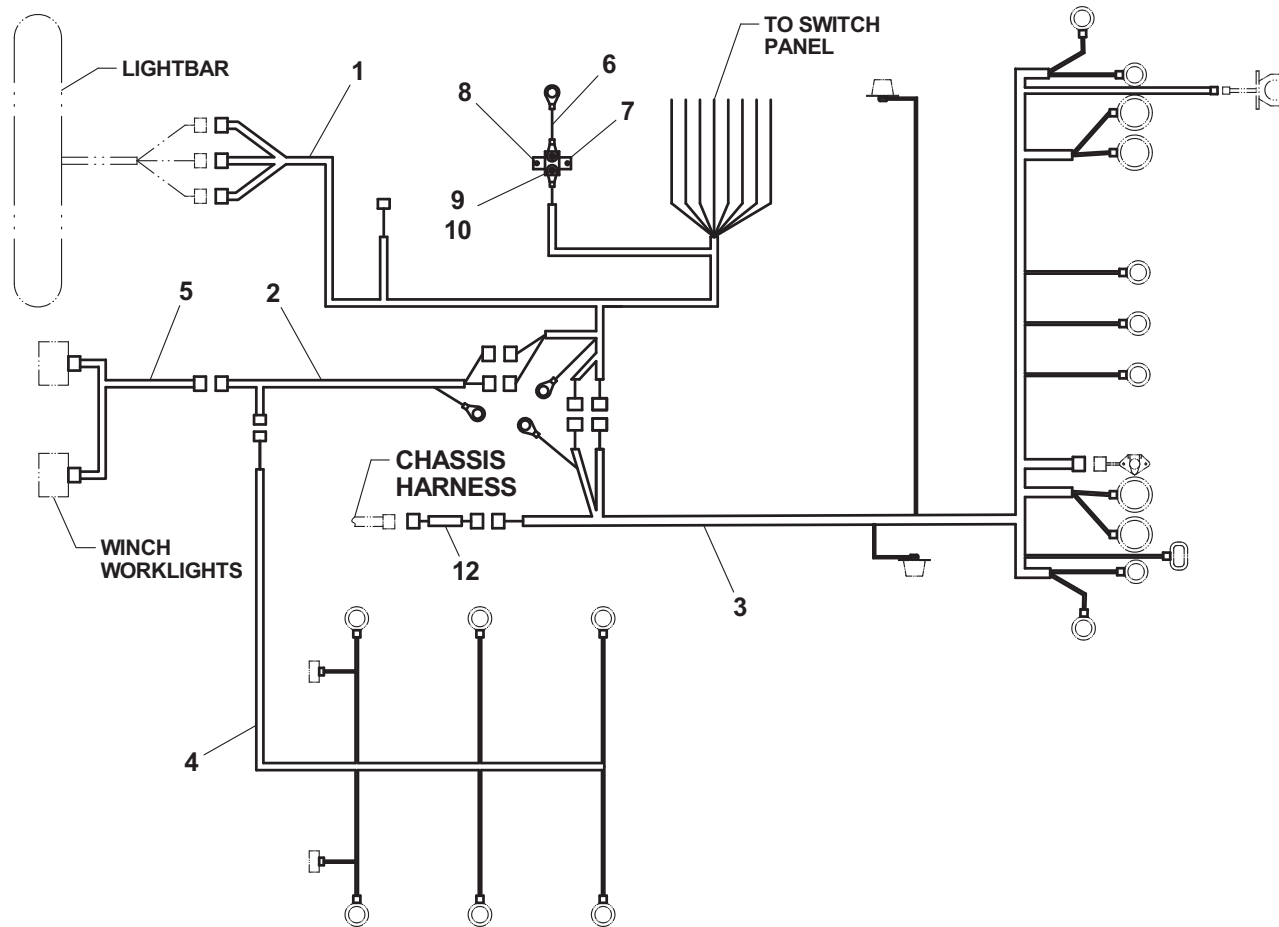

Item #11, Clip and #13, Tubing, not shown.

ELECTRICAL COMPONENTS - OPTIONAL (TAIL LIGHT CONVERTER)

ITEM	PART NO.	DESCRIPTION	QTY
1	7552000472	Harness	1
2	7590000432	Stop/Tail/Turn Light	2
3	7114101018	Capscrew, #10-24NC x 1.25"	6
4	7660102604	Locknut, #10-24NC	6

ELECTRICAL COMPONENTS - OPTIONAL (TAIL LIGHT CONVERTER)

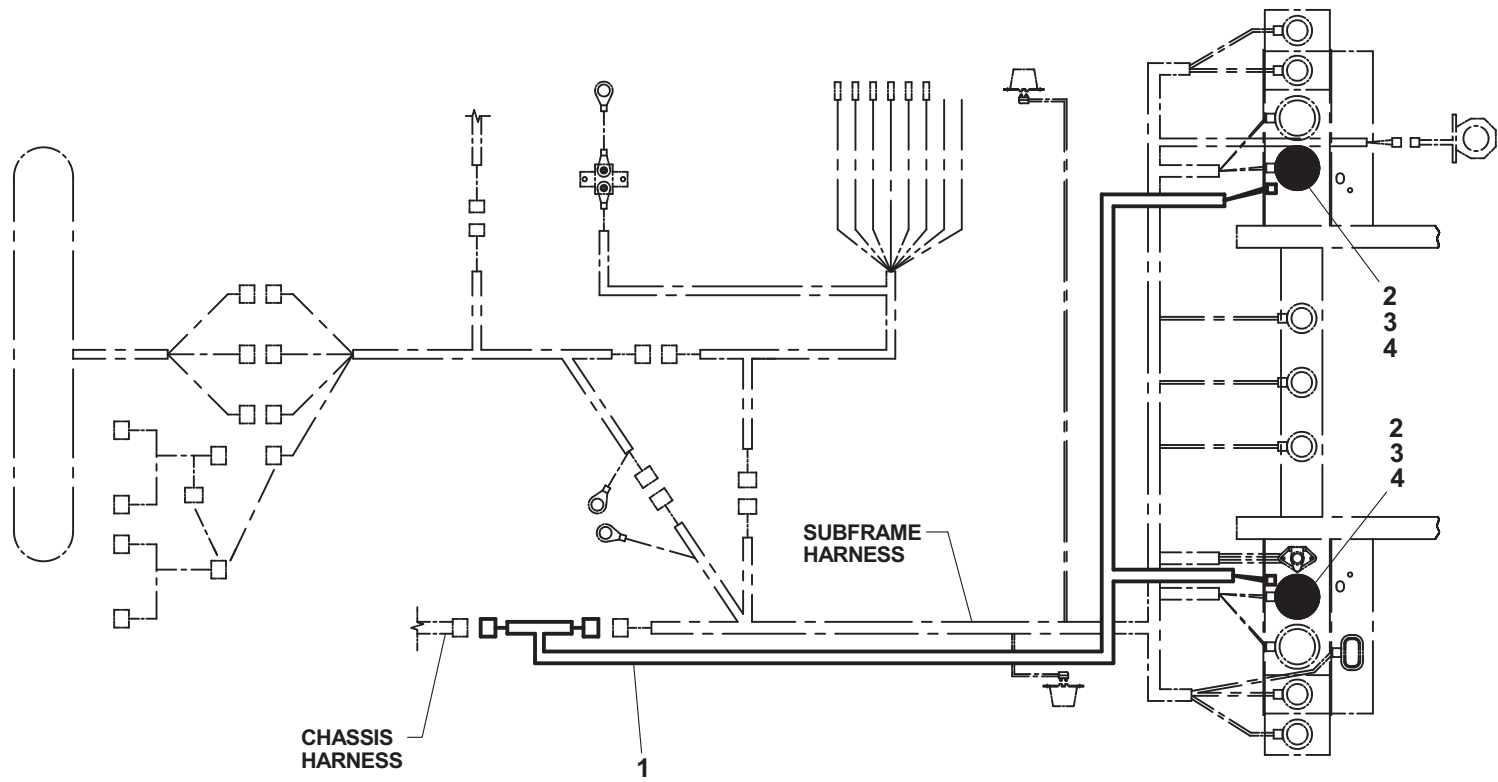

DECK MARKER LIGHTS

ITEM	PART NO.	DESCRIPTION	QTY
1	7493000009	Grommet	6
2	7590000342	Marker Light - Amber (LED)	4
3	7590000343	Marker Light - Red (LED)	2
4	7493000010	Grommet	2
5	7590000339	Marker Light - Amber (LED)	2

DECK MARKER LIGHTS

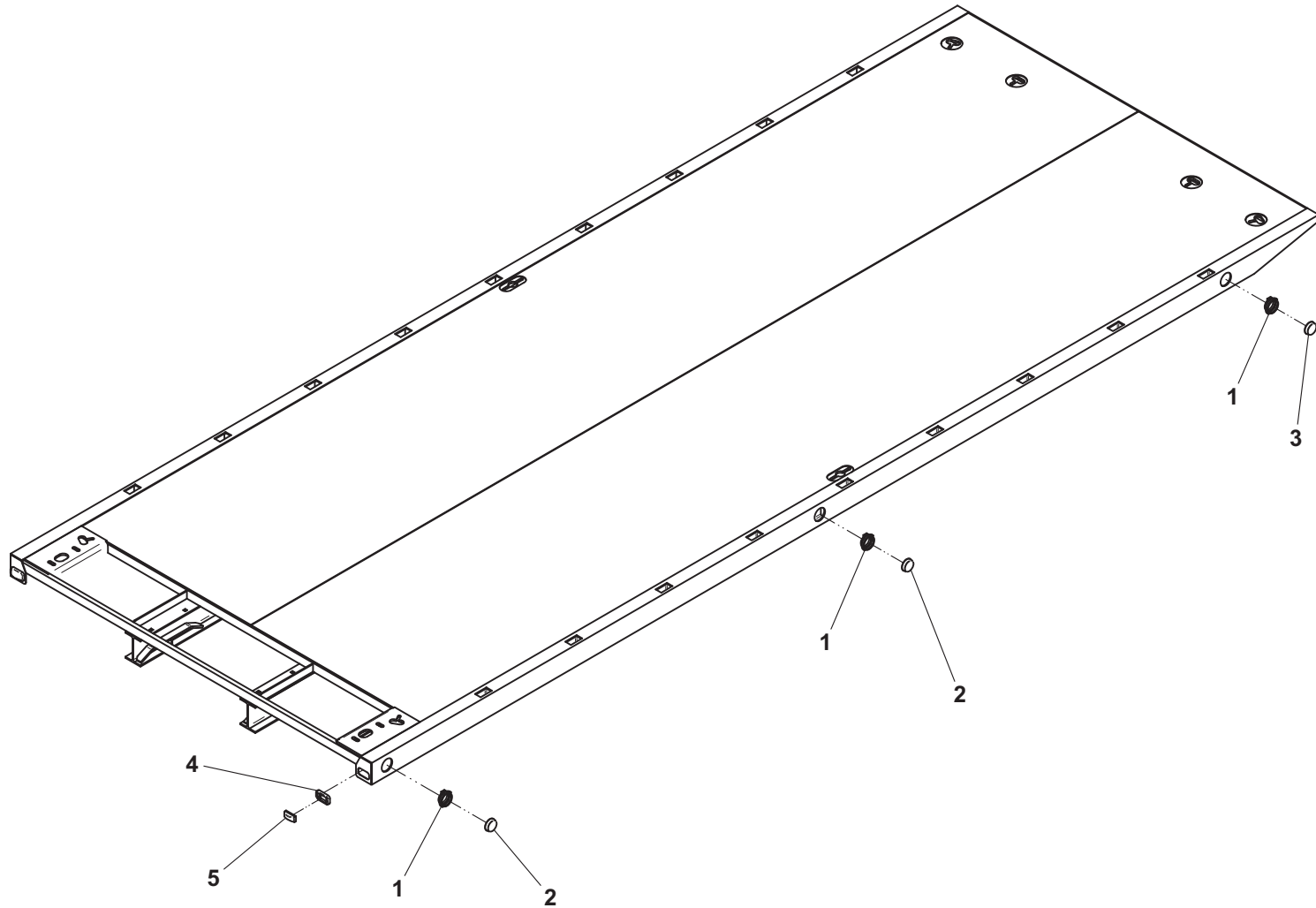

HEADBOARD SIDE MARKER LIGHTS

ITEM	PART NO.	DESCRIPTION	QTY
1	7493000009	Grommet (36" headboard)	2
	7493000009	Grommet (45", 50" & 57" headboards)	4
2	7590000342	Marker Light - Amber (LED) (36" headboard)	2
	7590000342	Marker Light - Amber (LED) (45", 50" & 57" headboards)	4
3	7552000409	Headboard to Cab Harness	1

HEADBOARD SIDE MARKER LIGHTS

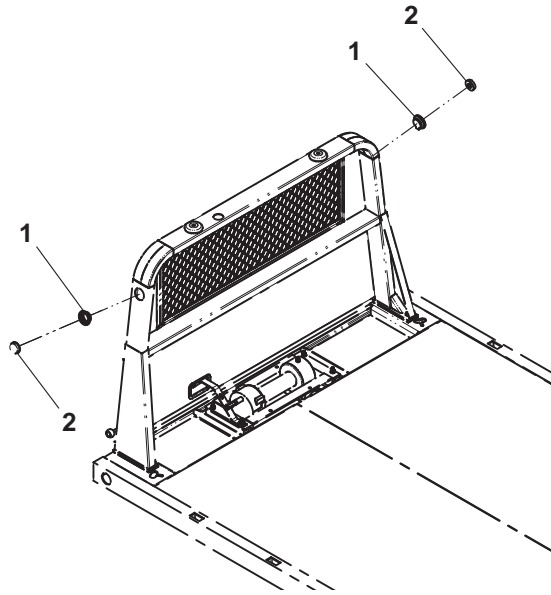

FOR 36" & 40" HEADBOARD

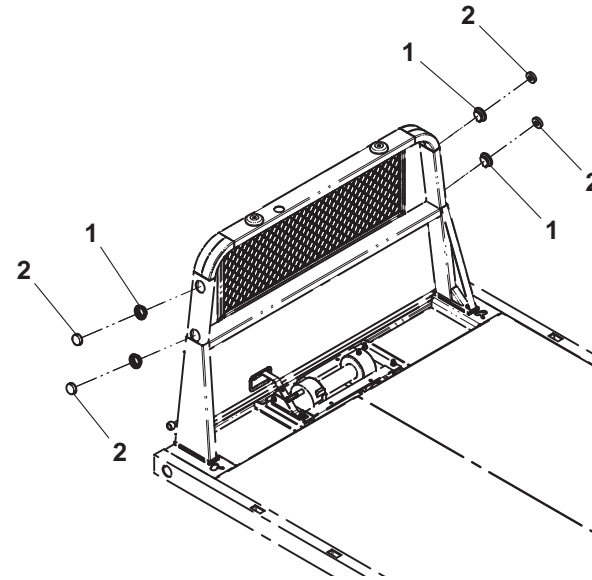

FOR 45", 50" & 57" HEADBOARD

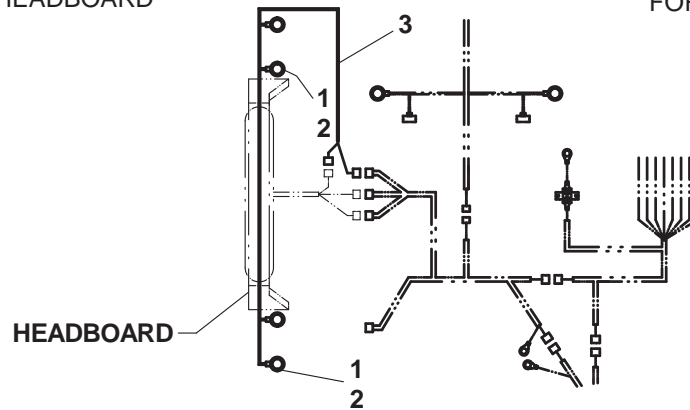

ADDITIONAL DECK MARKER LIGHTS

ITEM	PART NO.	DESCRIPTION	QTY
1	7493000009	Grommet	4
2	7590000342	Marker Light - Amber (LED)	4
3	7552000212	Additional Markers Deck Harness	1
4	4017001059	Angle	4
5	7280000018	Wire Clip	16

ADDITIONAL DECK MARKER LIGHTS

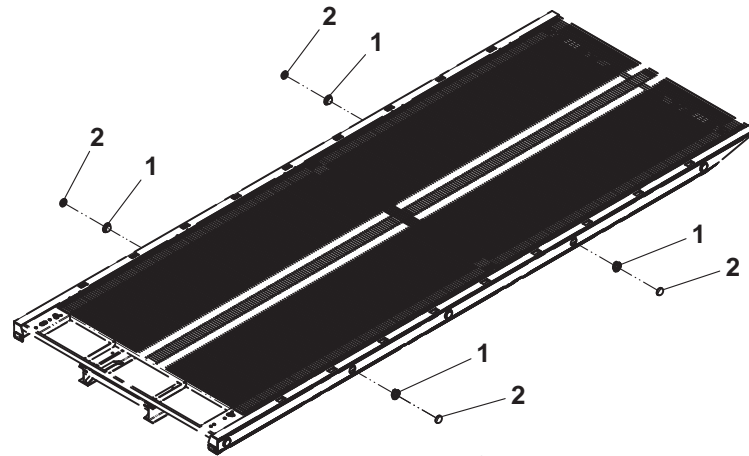

ALUMINUM DECK

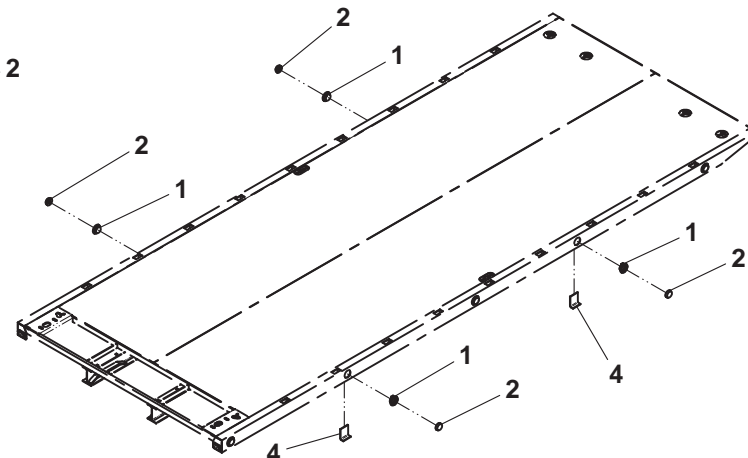

STEEL DECK

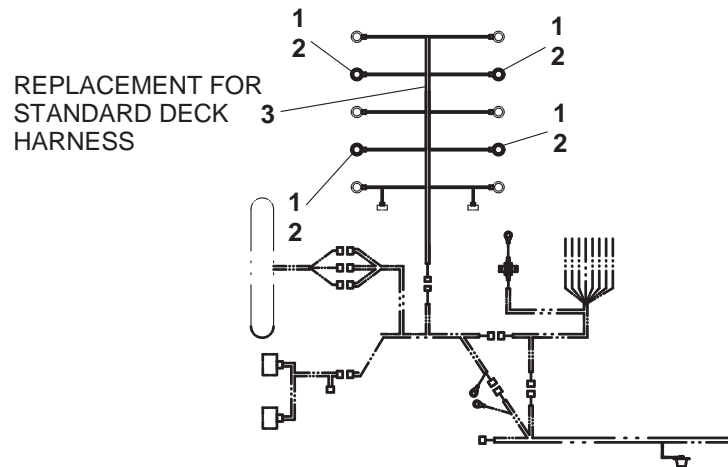

Item #5, Wire Clip, not shown.

IRL WHEEL LIFT

ITEM	PART NO.	DESCRIPTION	QTY
1	3170000162	Outer Boom Weld - Standard	1
	3170000504	Outer Boom Weld - Galvanized	
2	3911000078	Inner Boom Weld	1
3	3320000115	Cylinder Assembly	1
4	4691000296	Pin	1
5	4691000268	Pin	1
6	7754000006	Retaining Ring	4
7	7082000021*	Bushing	1
8	4679000046	Wear Pad	1
9	4017000739	Angle	2
10	7118140418	Capscrew, 0.25"-20NC x 0.50"	4
11	7950100151	Washer, 0.19" ID	4
12	4679000211	Wear Pad	1
13	3320000114	Cylinder Assembly	2
14	3691000164	Pin Weld	2
15	7115160950	Capscrew, 0.38"-16NC x 1.12"	6
16	7660162601	Locknut, 0.38"-16NC	6
17	3691000073	Pin Weld	3
18	3020000102	Arm Weld - Standard	2
	3020000131	Arm Weld - Galvanized	
19	7082000017+	Bearing	4
20	7082000018+	Bearing	4
21	3592000040	Link Assembly - Standard	1
	3592000066	Link Assembly - Galvanized	
22	3691000069	Pin Weld	1
23	7082000016^	Bearing	4
24	7291000010	4-Way Receptacle	1
25	7796000048	Gasket	1
26	7114140528	Screw	2
27	7660142601	Locknut	2

* included in Inner Boom Weld, P/N 3911000078

+ included in Arm Weld, P/Ns 3020000102 & 3020000131

^ included in Link Weld, P/Ns 3592000040 & 3592000066

IRL WHEEL LIFT

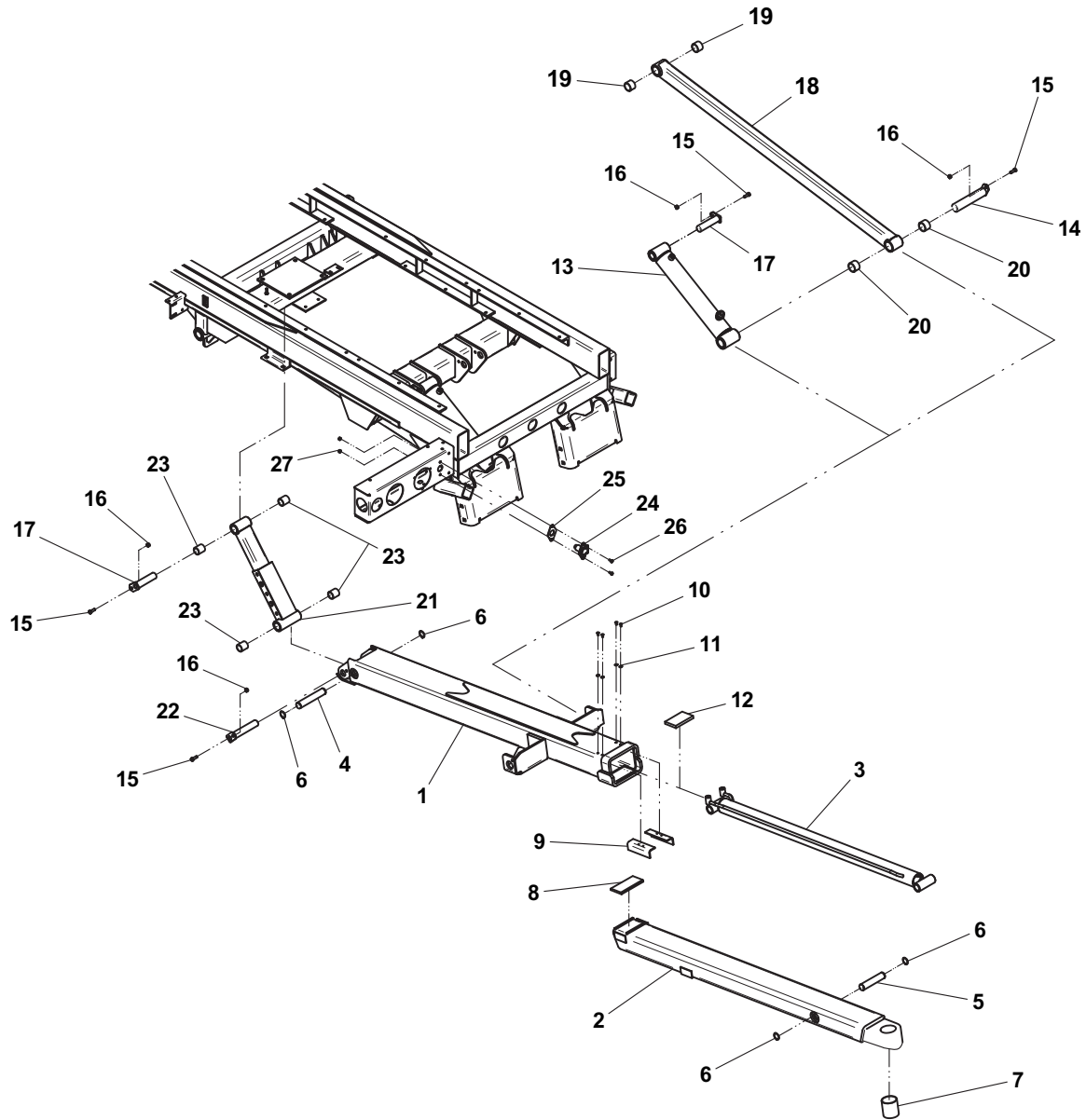

MANUAL L-ARM WHEEL LIFT GRID

ITEM	PART NO.	DESCRIPTION	QTY
1	3913000097	Pivot Tube Weld (w/ ball hitch plate)	1
	3913000100	Pivot Tube Weld (w/ 2" reese receiver)	
	3913000101	Pivot Tube Weld (w/ 2-1/2" reese receiver)	
2	3484000091	Grid Weld - LH	1
3	3484000090	Grid Weld - RH	1
4	4691000427	Pivot Pin	1
5	4949000047	Washer	2
6	7754000024	Retaining Ring	1
7	3551000036	T-Handle	2
8	3511880049	L-Arm Weld - Standard	2
	3020000132	L-Arm Weld - Galvanized	
9	7330000419	Reflective Tape	2
10	7330000420	Reflective Tape - LH	1
11	7330000432	Reflective Tape - RH	1
12	3551000011*	Cam Lock Assembly	2
13	7440030000^	Grease Fitting	2

* 3551000011, Cam Lock Assembly, included with 3484000091 & 3484000090, Grid Weld

^ 7440030000, Grase Fitting, included with 3551000011, Cam Lock Assembly

MANUAL L-ARM WHEEL LIFT GRID

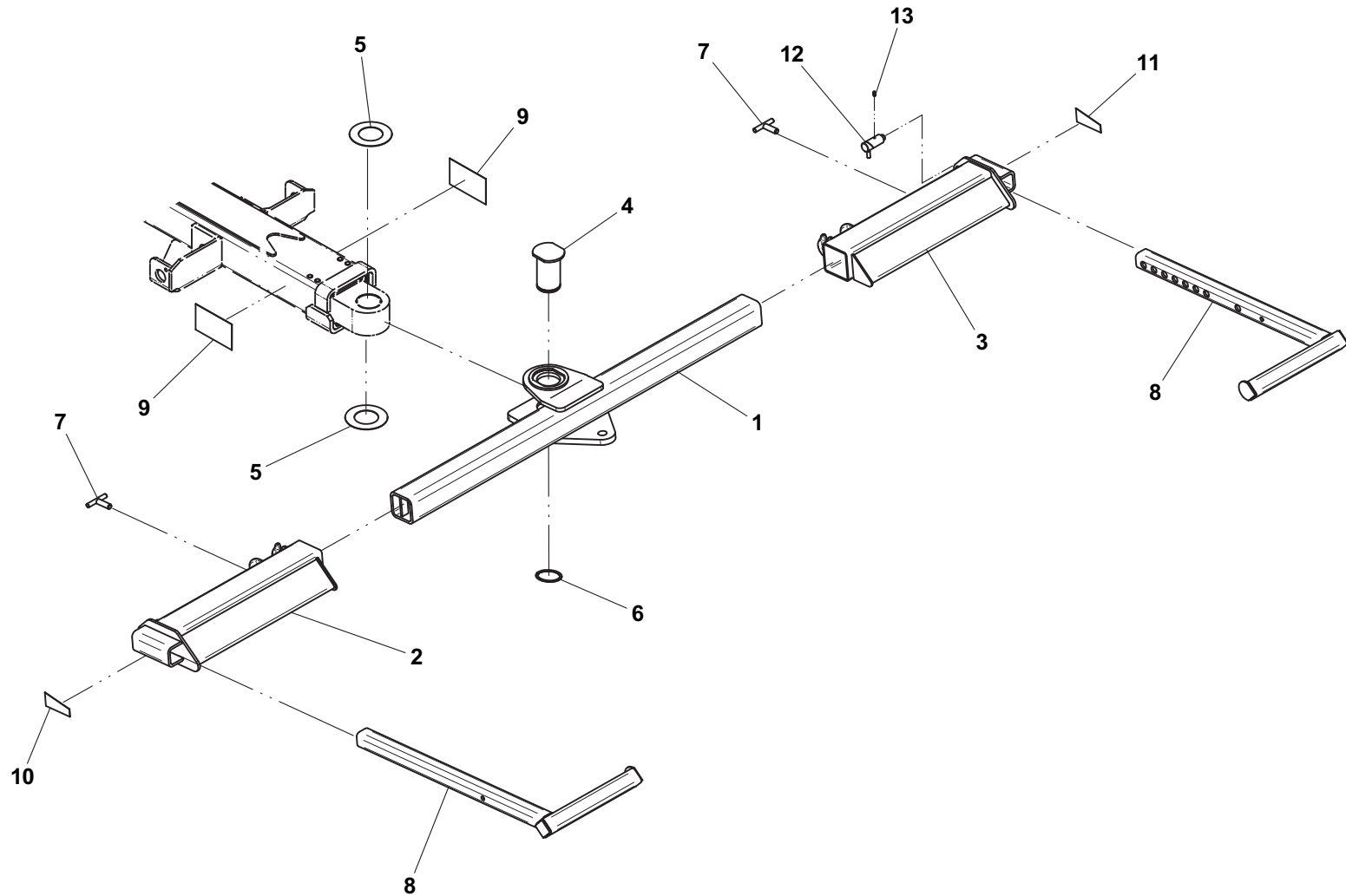

Pivot tube weld with IRL ball hitch mounting plate shown

MANUAL T37 PIVOTING WHEEL LIFT GRID

ITEM	PART NO.	DESCRIPTION	QTY	ITEM	PART NO.	DESCRIPTION	QTY
1	3913000097	Pivot Tube Weld (w/ ball hitch plate)	1	25	7330000432	Reflective tape	1
	3913000100	Pivot Tube Weld (w/ 2" reese receiver)		26	7950200000	Lockwasher, 0.63" ID	2
	3913000101	Pivot Tube Weld (w/ 2-1/2" reese receiver)					
2	3484000017*	Grid Weld - LH	1				
3	3484000016+	Grid Weld - RH	1				
4	4259000002*	Pivot Casting, LH	1				
5	4259000001+	Pivot Casting, RH	1				
6	4691000354*+	Pin	2				
7	4691000357*+	Pin	2				
8	7754000037*+	Retaining Ring	2				
9	3551000036	T-Handle	2				
10	4691000186*+	Pin	2				
11	7843000006*+	Spring	2				
12	4763000184*+	Rod	2				
13	4254000005*+	Cap	2				
14	7786000006*+	Screw	2				
15	7843000016*+	Spring	2				
16	4691000183*+	Pin	2				
17	4691000427	Pivot Pin	1				
18	4949000047	Washer	2				
19	7754000024	Retaining Ring	1				
20	7440030000	Grease Fitting	6				
21	3020000029	L-Arm Weld - LH	1				
22	3020000030	L-Arm Weld - RH	1				
23	7330000419	Reflective Tape	2				
24	7330000420	Reflective Tape	1				

* also available in Grid Assembly, LH, P/N 3484000047

+ also available in Grid Assembly, RH, P/N 3484000046

MANUAL T37 PIVOTING WHEEL LIFT GRID

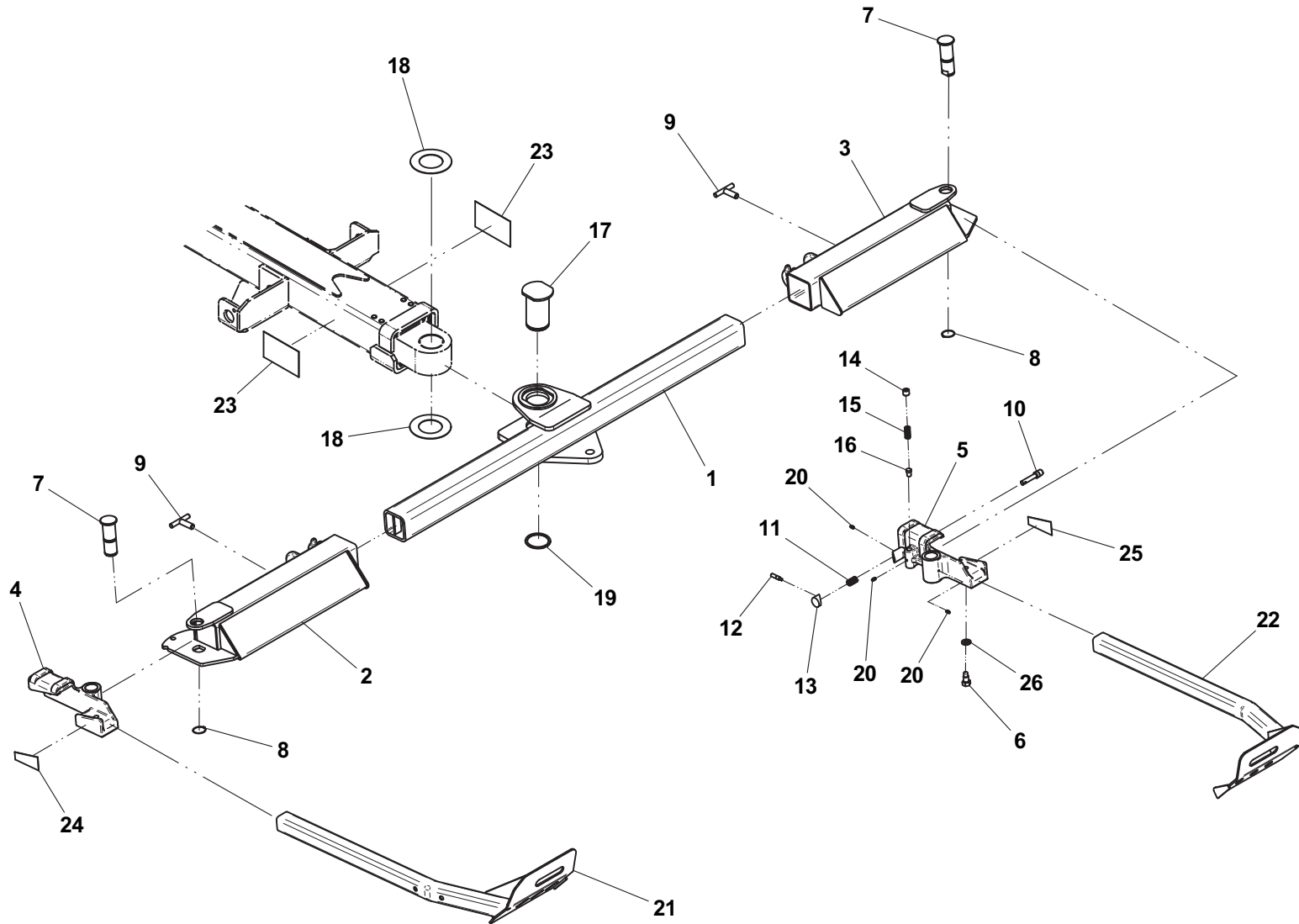

Pivot tube weld with IRL ball hitch mounting plate shown

HYDRAULIC REAR DOCK STABILIZER

ITEM	PART NO.	DESCRIPTION	QTY
1	3849000043	Stabilizer Weld	1
2	3320000119	Cylinder Assembly	2
3	3691000165	Pin Weld	2
4	3691000073	Pin Weld	2
5	7115160950	Capscrew, 0.38"-16NC x 1.12"	4
6	7660162601	Locknut, 0.38"-16NC	4
7	7082000017*	Bearing	4

* included in Stabilizer Weld, P/N 3849000043

HYDRAULIC REAR DOCK STABILIZER

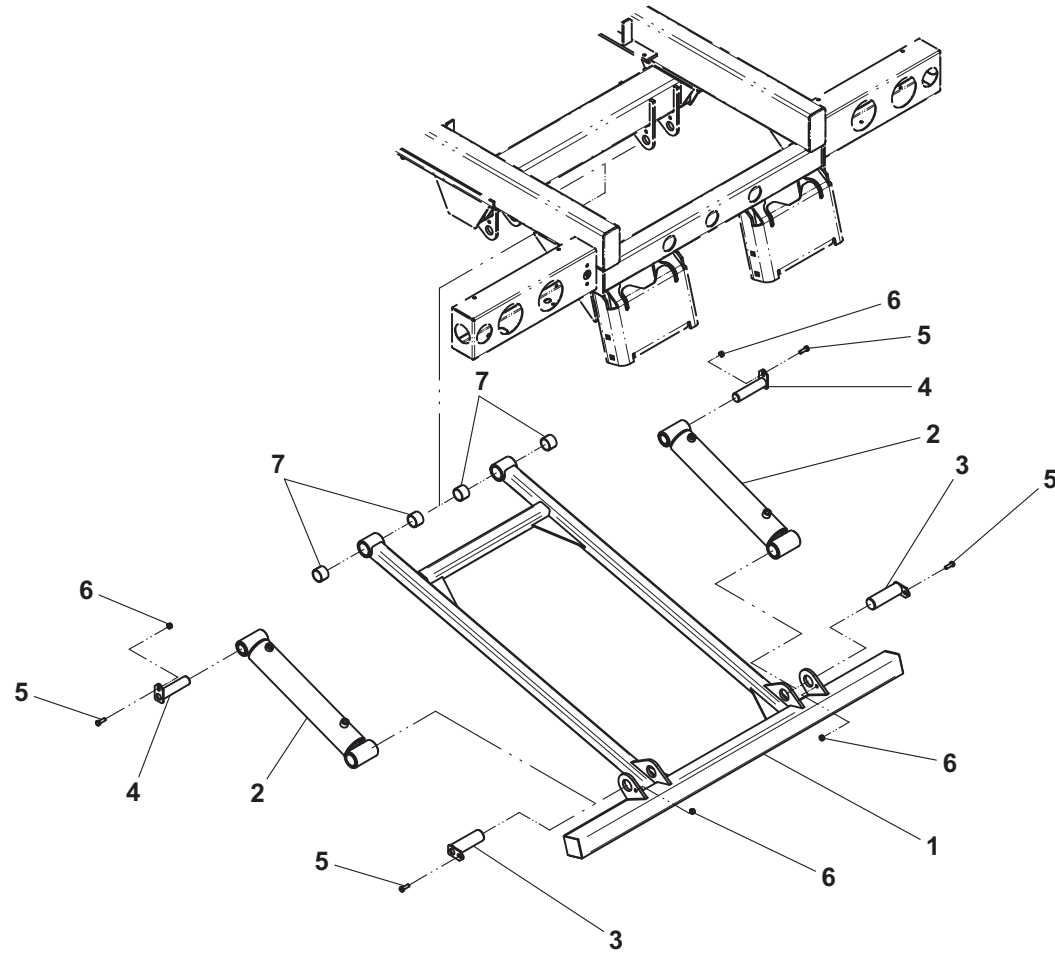

HYDRAULIC REAR DOCK STABILIZER WITH REESE HITCH RECEIVER

ITEM	PART NO.	DESCRIPTION	QTY
1	3849000044	Stabilizer Weld (with 2.50" Reese Hitch Receiver)	1
2	3320000114	Cylinder Assembly	2
3	3691000165	Pin Weld	2
4	3691000073	Pin Weld	2
5	7115160950	Capscrew, 0.38"-16NC x 1.12"	4
6	7660162601	Locknut, 0.38"-16NC	4
7	7082000017*	Bearing	4
8	7291000010	4-Way Receptacle	1
9	7796000048	Gasket	1
10	7114140528	Screw, 0.25"-20NC x .63"	2
11	7660142601	Locknut, 0.25"-20NC	2

* included in Stabilizer Weld, P/N 384900004

HYDRAULIC REAR DOCK STABILIZER WITH REESE HITCH RECEIVER

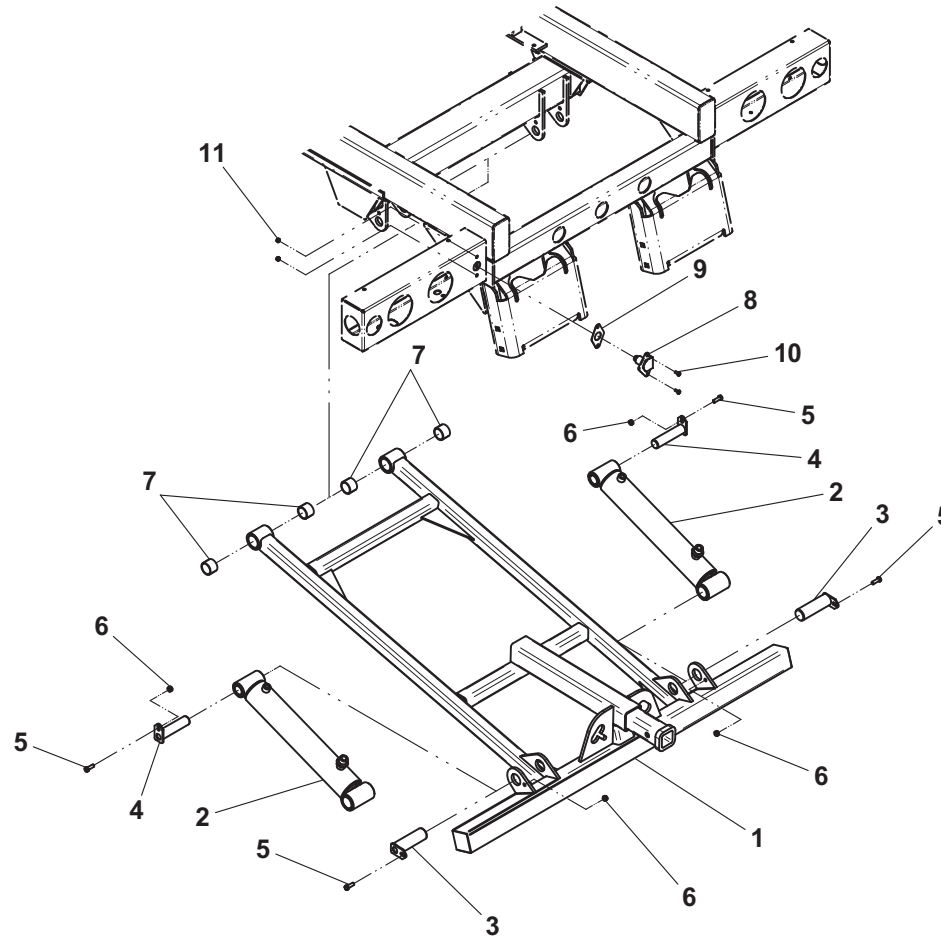

ROLL CYLINDER ASSEMBLY - P/N 3320000238

ITEM	PART NO.	DESCRIPTION	QTY
1	3071000220	Barrel Weld	1
2	4763000093	Rod	1
3	4698000009*	Piston	1
4	7754000013* #	Wear Ring	2
5	7796000064* #	Piston Locking "T" Seal	1
6	7755226609* #	Back-Up Ring	2
7	7755226000* #	"O" Ring	1
8	4553000010^	Head	1
9	7755338000^ #	"O" Ring	1
10	7755338609^ #	Back-Up Ring	1
11	7754000012^ #	Wear Ring	1
12	7796000025^ #	Rod Seal	1
13	7796000008^ #	Rod Wiper Seal	1
14	7754000016 #	Retaining Ring	1
15	7754000027 #	Retaining Ring	1
16	7661000035	Locknut	2

* included in Piston Assembly, P/N 3698000004

^ included in Head Assembly, P/N 3553000014

available only in Service Kit #7577250025

ROLL CYLINDER ASSEMBLY - P/N 3320000238

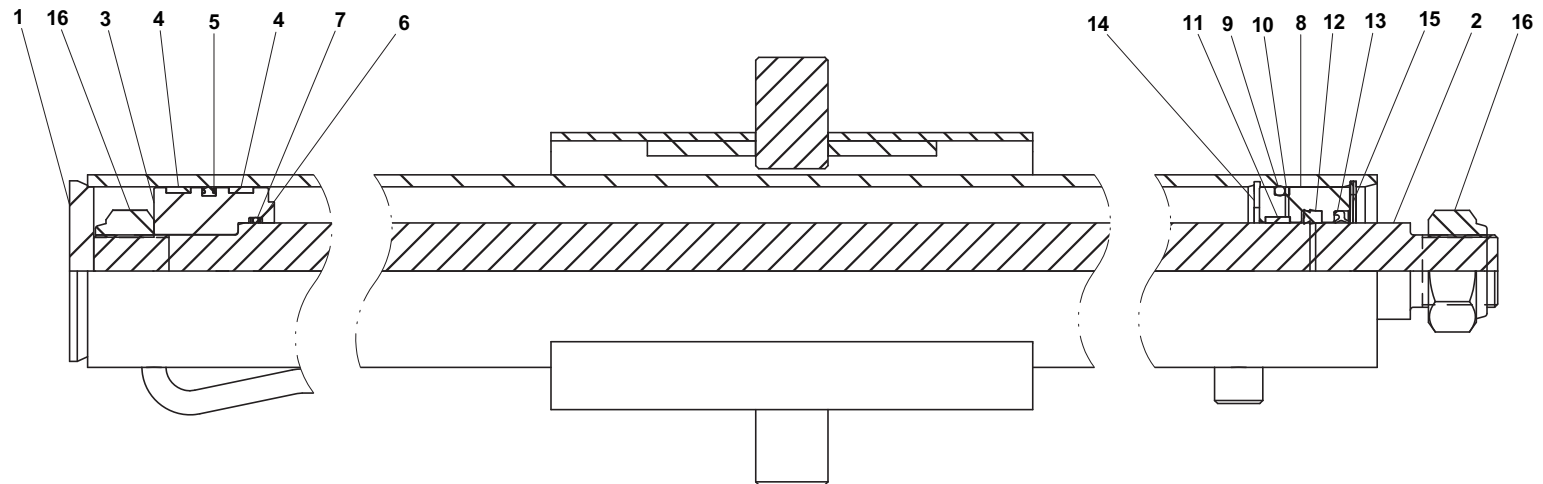

TILT CYLINDER ASSEMBLY - P/N 3320000122

ITEM	PART NO.	DESCRIPTION	QTY
1	3071000117	Barrel Weld	1
2	3763000127	Rod Weld	1
3	4698000007*	Piston	1
4	7754000003* #	Wear Ring	2
5	7796000063* #	Piston Locking "T" Seal	1
6	7755224609* #	Back-Up Ring	2
7	7755224000* #	"O" Ring	1
8	4553000008^	Head	1
9	7755330008^ #	"O" Ring	1
10	7755334609^ #	Back-Up Ring	1
11	7754000004^ #	Wear Ring	1
12	7796000045^ #	Rod Seal	1
13	7796000024^ #	Rod Wiper Seal	1
14	7754000002#	Retaining Ring	1
15	7754000026#	Retaining Ring	1
16	7661000034	Locknut	1
17	7082000016	Bearing	4

* included in Piston Assembly, P/N 3698000001

^ included Head Assembly, P/N 3553000011

available only in Service Kit #7577250042

TILT CYLINDER ASSEMBLY - P/N 3320000122

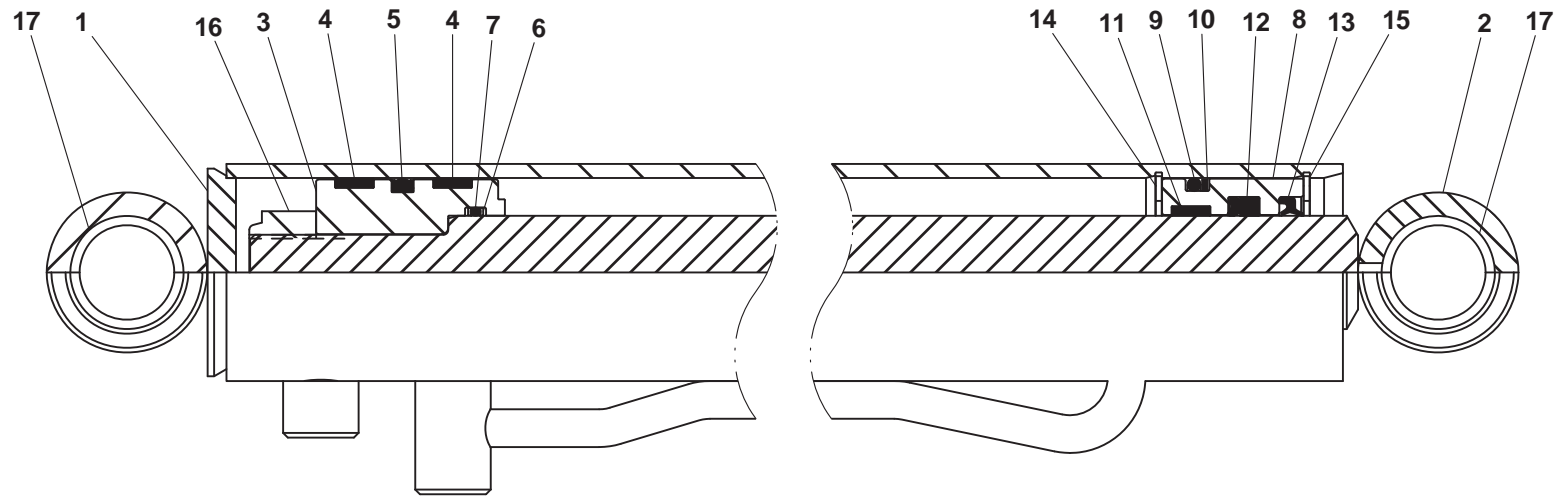

WHEEL LIFT EXTEND CYLINDER ASSEMBLY - P/N 3320000115

ITEM	PART NO.	DESCRIPTION	QTY
1	3071000106	Barrel Weld	1
2	3763000119	Rod Weld	1
3	4698000015*	Piston	1
4	7754000053* #	Wear Ring	2
5	7796000067* #	Piston Locking "T" Seal	1
6	7755222609* #	Back-Up Ring	2
7	7755222000* #	"O" Ring	1
8	4553000016^	Head	1
9	7755330000^#	"O" Ring	1
10	7755330609^#	Back-Up Ring	1
11	7754000054^#	Wear Ring	1
12	7796000045^#	Rod Seal	1
13	7796000046^#	Rod Wiper Seal	1
14	7754000051#	Retaining Ring	2
15	7661000034	Locknut	1

* included in Piston Assembly, P/N 3698000006

^ included in Head Assembly, P/N 3553000016

available only in Service Kit #7577250206

WHEEL LIFT EXTEND CYLINDER ASSEMBLY - P/N 3320000115

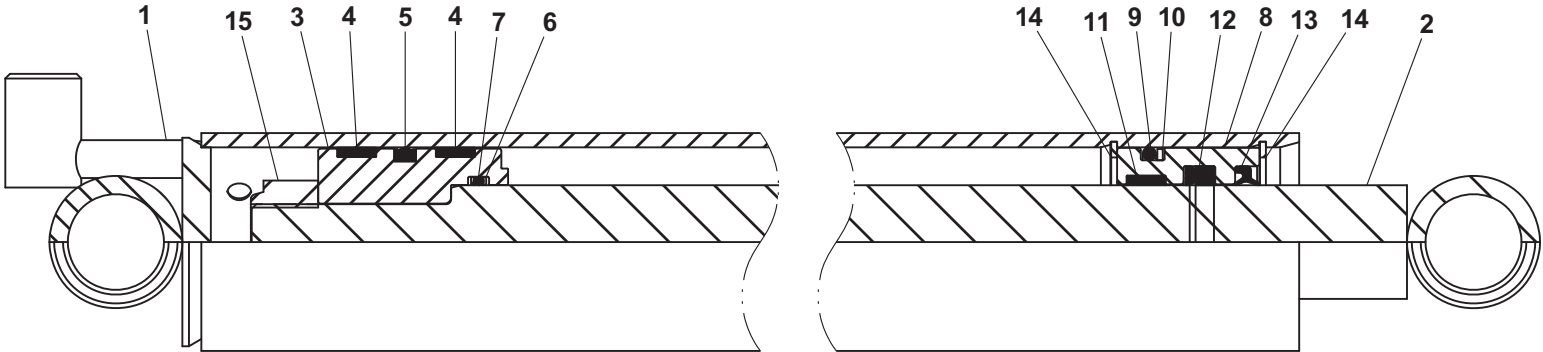

IRL/STABILIZER CYLINDER ASSEMBLY - P/N 3320000114

ITEM	PART NO.	DESCRIPTION	QTY
1	3071000105	Barrel Weld	1
2	3763000118	Rod Weld	1
3	4698000007*	Piston	1
4	7754000003* #	Wear Ring	2
5	7796000063* #	Piston Locking "T" Seal	1
6	7755224609* #	Back-Up Ring	2
7	7755224000* #	"O" Ring	1
8	4553000008^	Head	1
9	7755334000^ #	"O" Ring	1
10	7755334609^ #	Back-Up Ring	1
11	7754000004^ #	Wear Ring	1
12	7796000024^ #	Rod Seal	1
13	7796000008^ #	Rod Wiper Seal	1
14	7754000002 #	Retaining Ring	1
15	7754000026 #	Retaining Ring	1
16	7661000034	Locknut	1
17	7082000016	Bearing	2
18	7082000018	Bearing	2

* included in Piston Assembly, P/N 3698000001

^ included in Head Assembly, P/N 3553000011

available only in Service Kit #7577250024

IRL/STABILIZER CYLINDER ASSEMBLY - P/N 3320000114

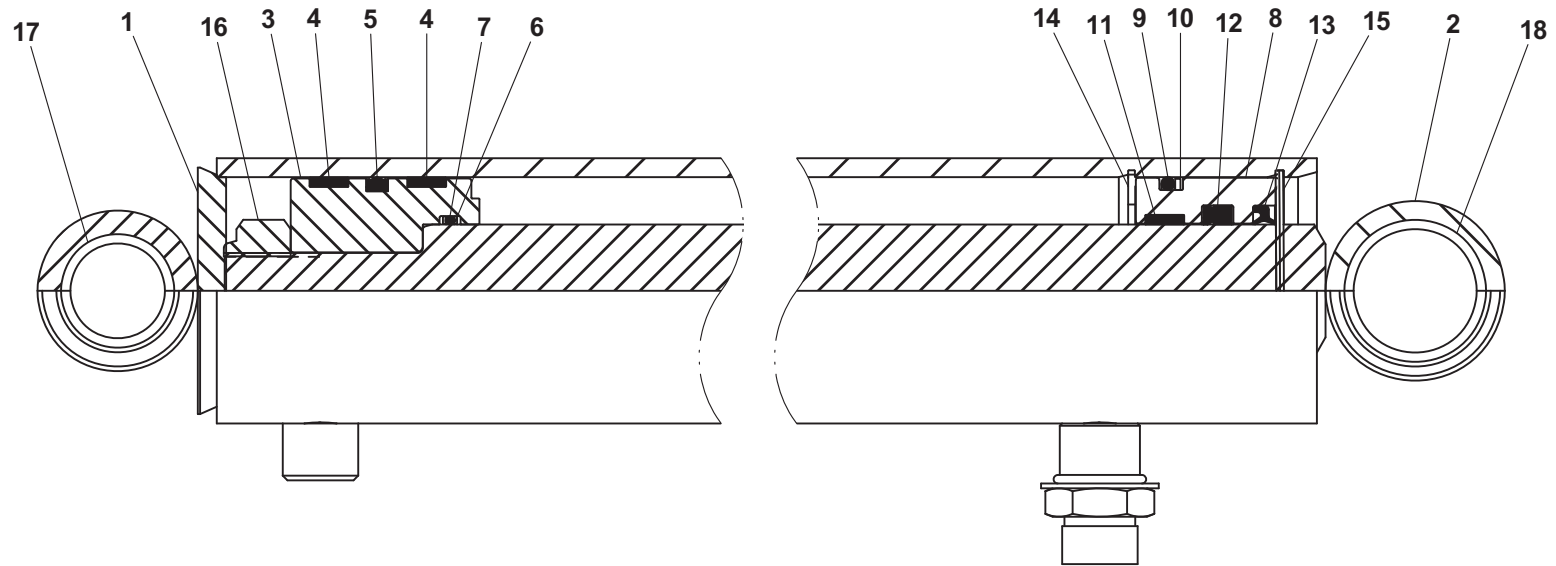

STABILIZER CYLINDER ASSEMBLY - P/N 3320000119

ITEM	PART NO.	DESCRIPTION	QTY
1	3071000110	Barrel Weld	1
2	3763000118	Rod Weld	1
3	4698000007*	Piston	1
4	7754000003* #	Wear Ring	2
5	7796000063* #	Piston Locking "T" Seal	1
6	7755224609* #	Back-Up Ring	2
7	7755224000* #	"O" Ring	1
8	4553000008^	Head	1
9	7755334000^ #	"O" Ring	1
10	7755334609^ #	Back-Up Ring	1
11	7754000004^ #	Wear Ring	1
12	7796000024^ #	Rod Seal	1
13	7796000008^ #	Rod Wiper Seal	1
14	7754000002 #	Retaining Ring	1
15	7754000026 #	Retaining Ring	1
16	7661000034	Locknut	1
17	7082000016	Bearing	2
18	7082000018	Bearing	2

* included in Piston Assembly, P/N 3698000001

^ included in Head Assembly, P/N 3553000011

available only in Service Kit #7577250024

STABILIZER CYLINDER ASSEMBLY - P/N 3320000119

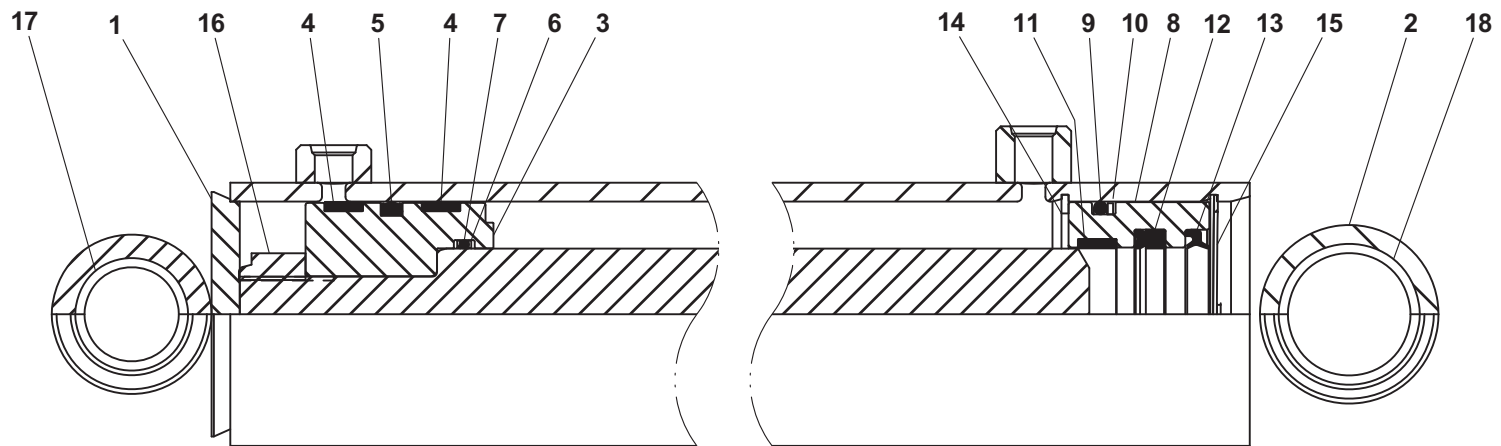

LIGHTBARS

ITEM	PART NO.	DESCRIPTION	QTY
1	7590000363	Lightbar, Amber LED	1
2	4178000402	Bracket (standard mount)	2
	4178000437	Bracket (high mount)	
3	7115180850	Capscrew, 0.50"-13NC x 1.00"	2
4	7950180252	Flatwasher, 0.50" ID	2
5	7950180000	Lockwasher, 0.50" ID	2

LIGHTBARS

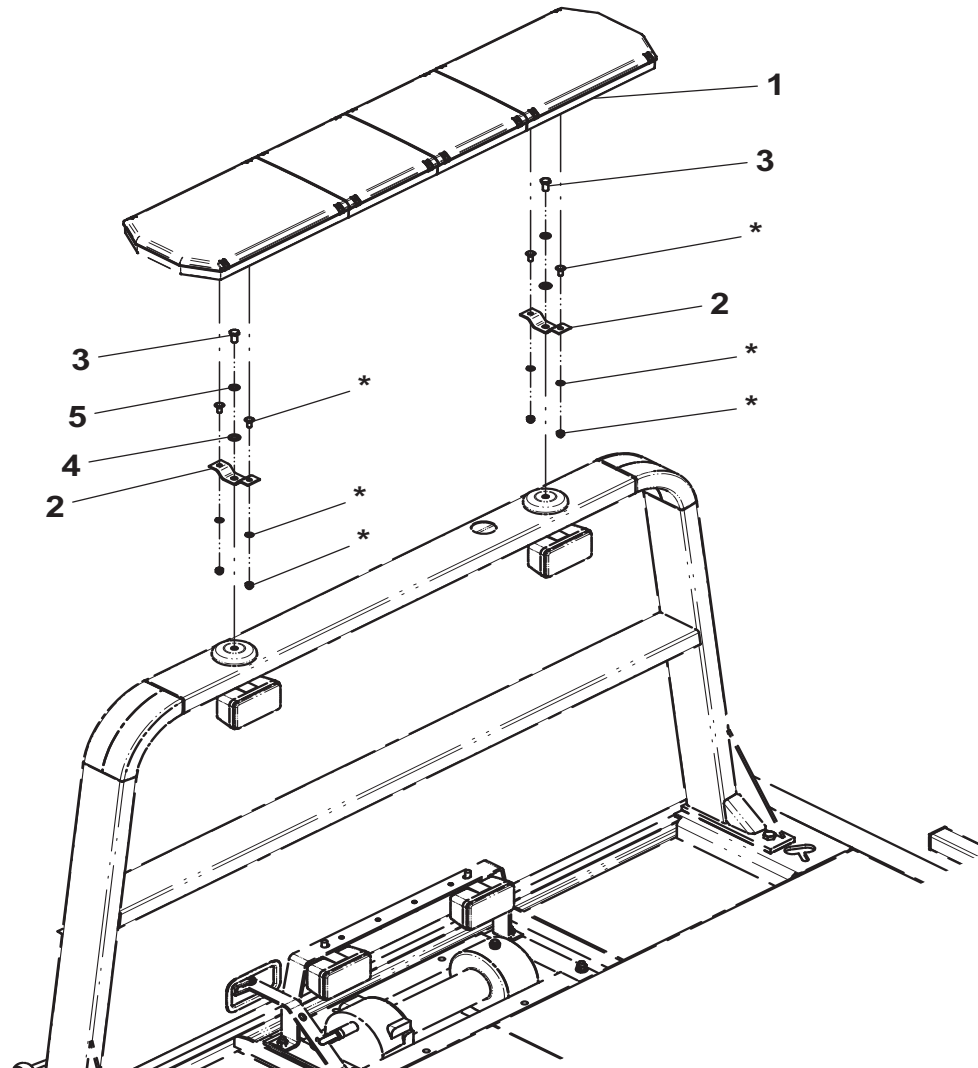

* included in Lightbar

SWITCH PANELS

ITEM	PART NO.	DESCRIPTION	QTY
1	4178000403	Bracket - 1 Function Switch Panel	1
2	4178000427	Bracket - 2 Function Switch Panel	1
3	7870000083	Switch	1
4	7870000113	Switch Panel - 3 Function, Mini In-Dash	1
5	7870000100	Switch Panel - 3 Function, In-Dash	1
6	7870000106	Switch Panel - 5 Function, In-Dash	1
7	7870000134	Switch Panel - 3 Function, Under Dash	1
8	7870000137	Switch Panel - 5 Function, Under Dash	1
9	2870000022	Switch Panel - 3 Function, In-Dash for Ford F650/750	1
10	2870000021	Switch Panel - 5 Function, In-Dash for Ford F650/750	1
11	7870000053	Switch Panel - 3 Function, Under Dash	1
12	7870000063	Switch Panel - 5 Function, Under Dash	1
13	7870000076	Switch Panel - 3 Function, In-Dash	1

SWITCH PANELS

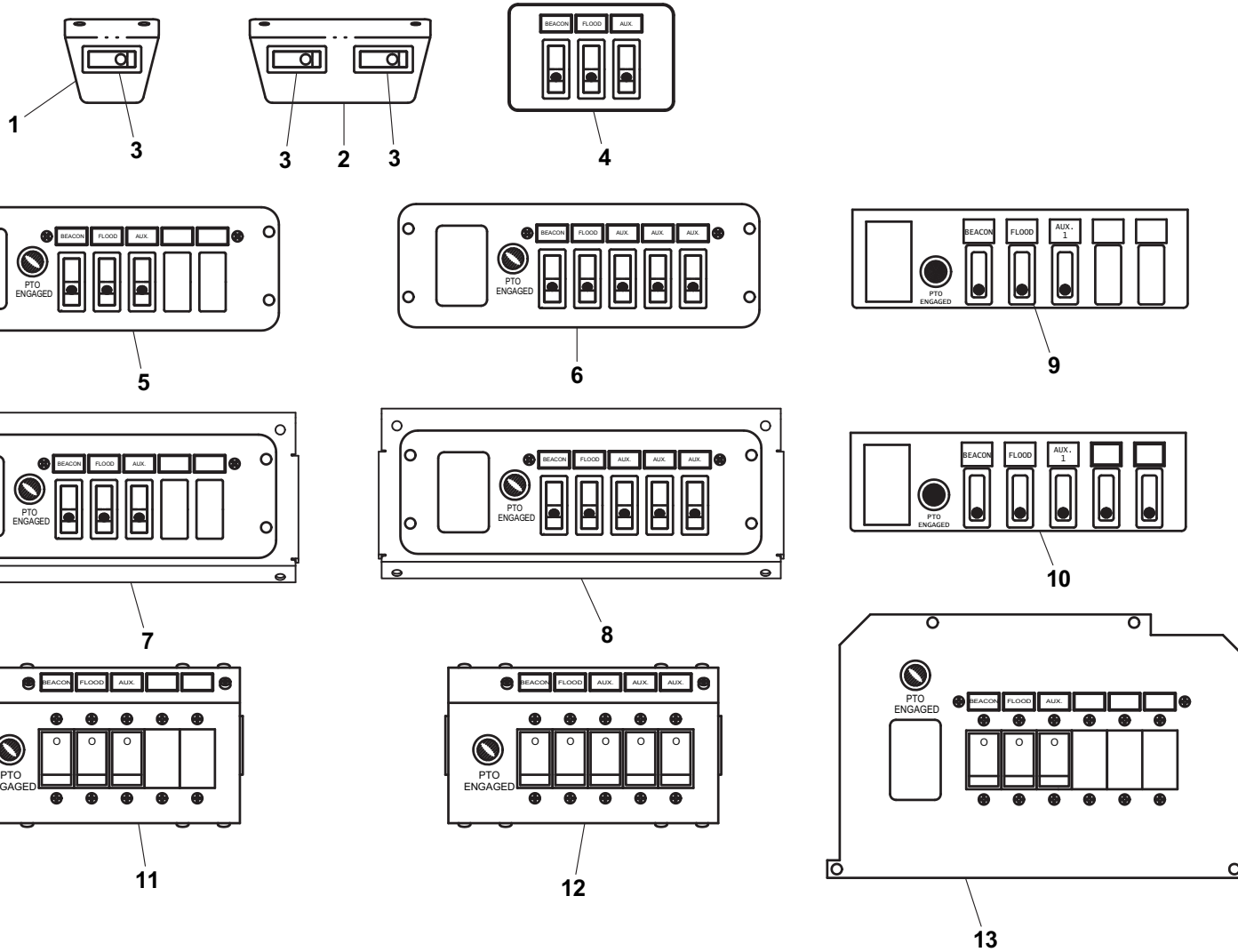

WORK LIGHTS

ITEM	PART NO.	DESCRIPTION	QTY
1	7590000223	Work Light	4
2	4178000402	Bracket	2
3	7790151253	Screw, 0.31"-18NC x 0.75	4
4	7493000003	Grommet	2
5	7552000222	Harness - Headboard Work Lights	1
	7552000360	Harness - Headboard Work Lights (Bucket Rest Headboard Only)	1
6	4178000423	Bracket	1
7	7280000011	Clip - Winch Work Lights	6
8	7552000166	Harness - Winch Work Lights	1
9	7590000185	Work Light	2

WORK LIGHTS

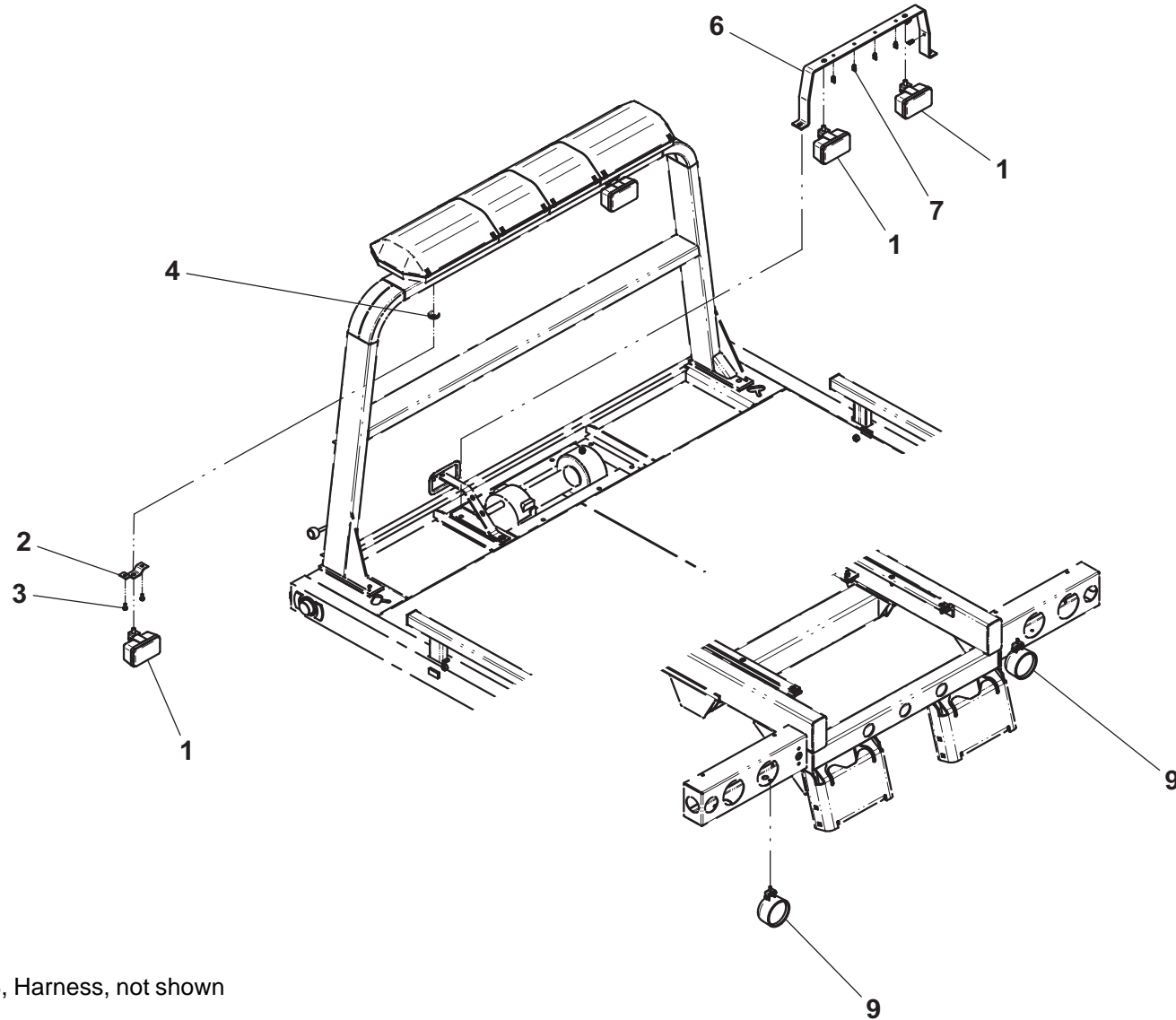

Items #5 & #8, Harness, not shown

BOLT-ON D-RINGS

ITEM	PART NO.	DESCRIPTION	QTY
1	3556000019	D-Ring	1
2	7115182050	Capscrew, 0.50"-13NC x 2.50"	2
3	7660182601	Locknut, 0.50"-13NC	2

BOLT-ON D-RINGS

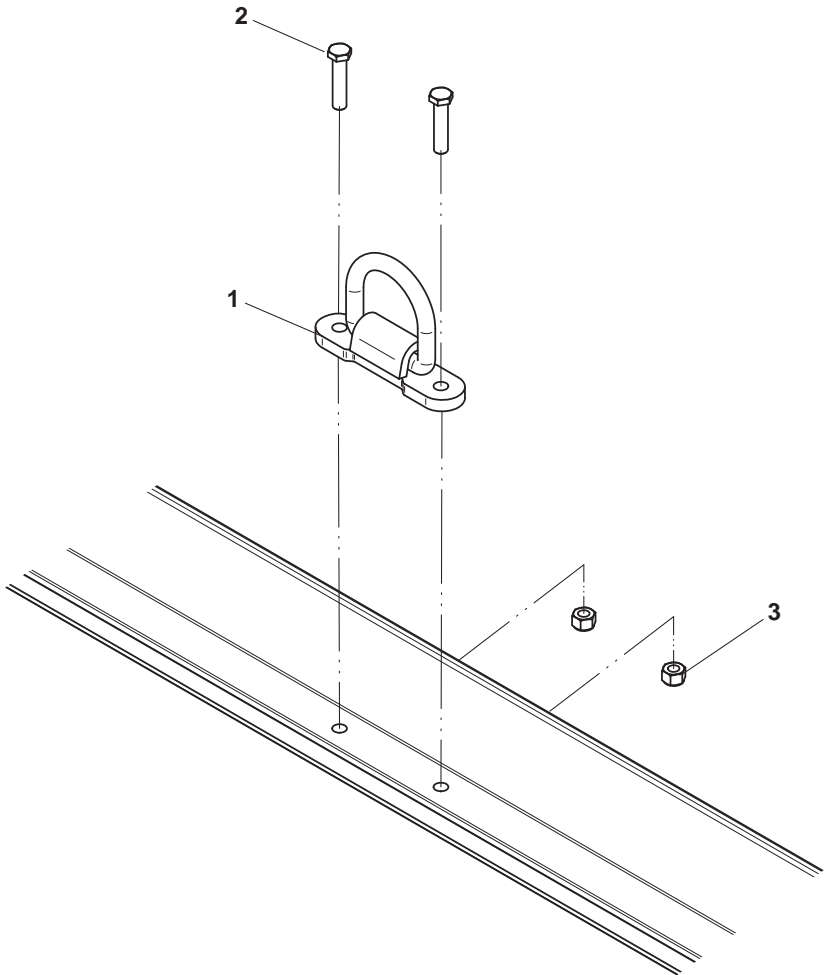

1, 2, 3, 4 OR 5 REMOTE CONTROL OPERATIONS

ITEM	PART NO.	DESCRIPTION	QTY	ITEM	PART NO.	DESCRIPTION	QTY
1	7005000003	Linear Actuator 12V	1*	18	4706005595	Plate (2, 3, 4, or 5 remote operations)	1
2	4706005361	Plate	2	19	7330000696	Decal - Controller Functions (3, 4, or 5 remote operations)	1
3	7115150864	Carriage Bolt, 0.31"-18NC x 1.00"	4				
4	7950150161	Flatwasher, 0.31" ID	4	20	9295310032#	Transmitter (1 remote operation)	1
5	7660152601	Locknut, 0.31"-18NC	4		9295310033#	Transmitter (2 remote operations)	
6	4178000664	Bracket	1*		9295310034#	Transmitter (3 remote operations)	
7	4178000665	Bracket	1*		9295310036#	Transmitter (4 or 5 remote operations)	
8	7115150864	Carriage Bolt, 0.31"-18NC x 1.00"	2*	21	9295310030#	Belt Clip	1
9	7660152601	Locknut, 0.31"-18NC	2*	22	9295310042#	Rubber Boot (1 or 2 remote operations)	1
10	4691000141	Pin (3, 4 or 5 section control valve)	1		9295310029#	Rubber Boot (3, 4, or 5 remote operations)	
	4691000373	Pin (6 section control valve)		23	9295310037#	Receiver (1 remote operation)	1
	4691000374	Pin (7 section control valve)			9295310038#	Receiver (2 remote operations)	
11	4211000001	Bushing	4*		9295310039#	Receiver (3 remote operations)	
12	7950220141	Flatwasher, 0.75" ID	4		9295310050#	Receiver (4 or 5 remote operations)	
13	7754000009	Retaining Ring	2	24	7552000391	Harness (1 remote operation)	1
14	7295000106	Controller (1 remote operation)	1		7552000392	Harness (2 remote operations)	
	7295000108	Controller (2 remote operations)			7552000393	Harness (3 remote operations)	
	7295000109	Controller (3 remote operations)			7552000426	Harness (4 or 5 remote operations)	
	7295000111	Controller (4 or 5 remote operations)					
15	7114100810	Screw, #10-24NC x 1.00" (1 remote operation)	2				
	7114100810	Screw, #10-24NC x 1.00" (2, 3, 4, or 5 remote operations)	6				
16	7950140151	Flatwasher, 0.19" ID (1 remote operation)	2				
	7950140151	Flatwasher, 0.19" ID (2, 3, 4, or 5 remote operations)	8				
17	7660102604	Locknut, #10-18NC (1 remote operation)	2				
	7660102604	Locknut, #10-18NC (2, 3, 4, or 5 remote operations)	6				

* quantities are for 1 remote operation, adjust quantities for 2, 3, 4, or 5 remote operations

included with Controller, item #14

1, 2, 3, 4 OR 5 REMOTE CONTROL OPERATIONS

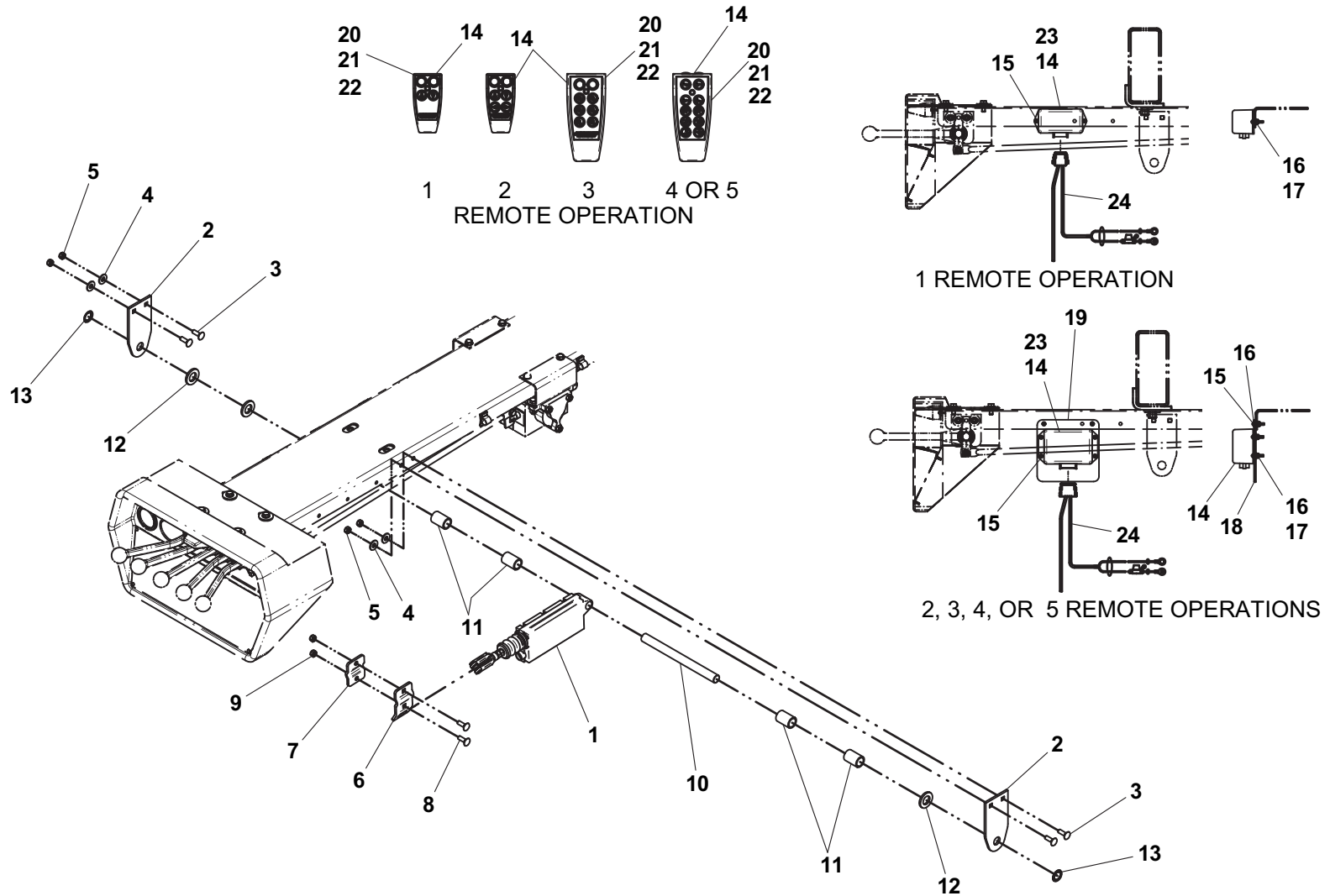

One Remote Operation shown

Items #19, Decal - Controller Functions, not shown

REMOTE THROTTLE CONTROL

ITEM	PART NO.	DESCRIPTION	QTY
1	7346000208	Pressure Switch	1
2	7552000241	Harness	1
3	7443000427*	Check Valve	1
4	7445060643*	Adapter	1
5	7443000432	Tee	1
6	7443000469	Fitting	1
7	7445040643	Adapter	1

* also available in Check Valve w/ Adapter, P/N 7443000428.

REMOTE THROTTLE CONTROL

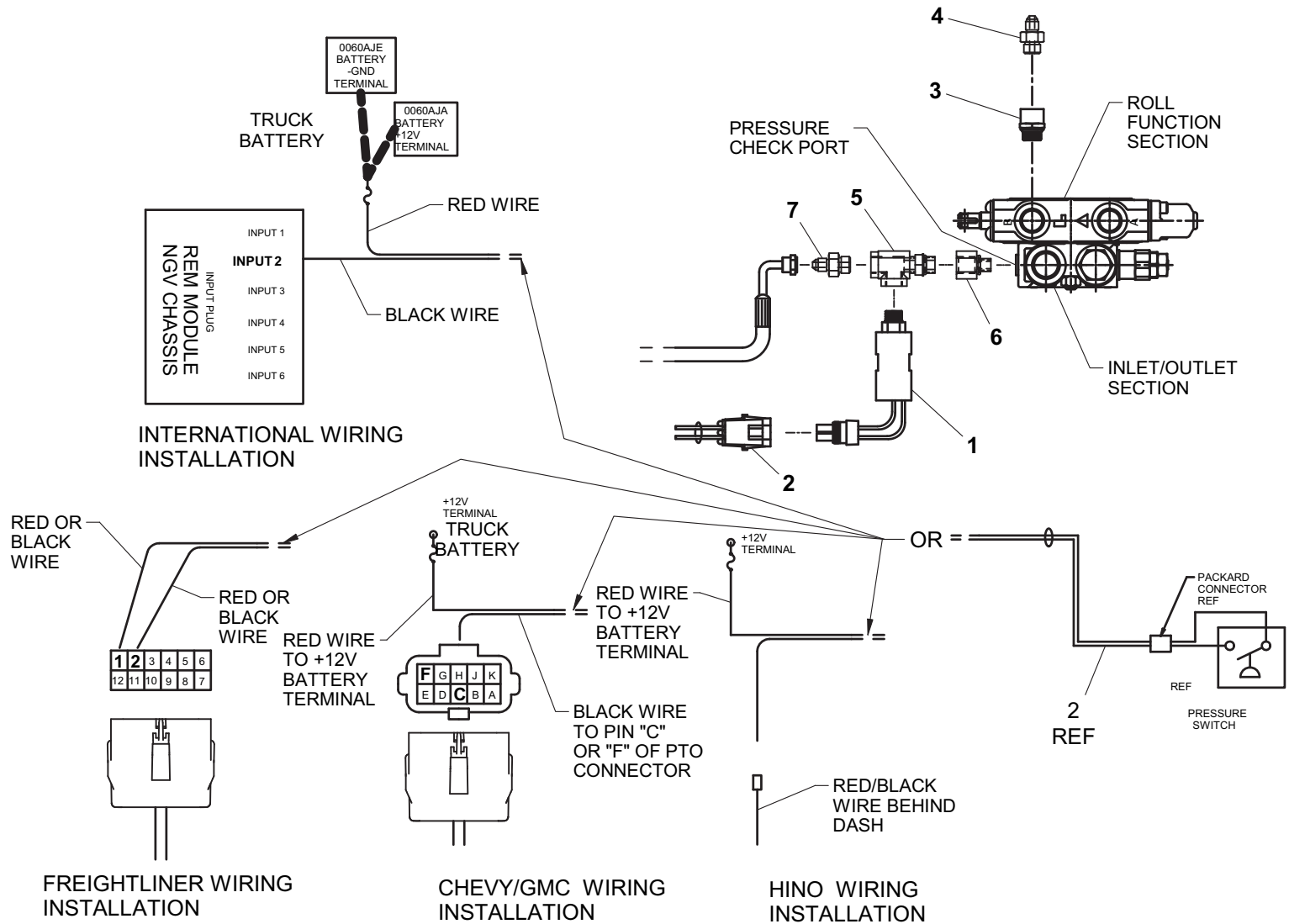

GLAD HANDS AND 7- WAY CONNECTOR

ITEM	PART NO.	DESCRIPTION	QTY
1	4178000666*	Bracket	1
2	7115181464*	Carriage Bolt, 0.50"-13NC x 1.75"	2
3	7660182601*	Locknut, 0.50"-13NC	2
4	7346000055+	Electrical Receptacle 7-way Connect	1
5	7346000078+	Electrical Boot	1
6	7111150813+	Capscrew, 0.31"-18NC x 1.00"	2
7	7660152601+	Locknut, 0.31"-18NC	2
8	7346000132	Electrical Adapter 7 to 4 way	1
9	7346000157	Electrical Adapter 7 to 6 way	1
10	7312000015^	Gladhand	1
11	7312000016^	Gladhand	1
12	7446502518^	Bulkhead Fitting	2
13	7446382506^	Connector	2
14	7577000145^	Seal Kit Gladhand	1
15	7565000014^	Airline Tubing	50 ft
16	7312000013^	Union	2

* also available in Bracket Install Glad Hands and 7 Way, P/N 2178000037

+ also available in Electrical Install 7 Way Connector, P/N 2346000008

^ also available in Glad Hand Install, P/N 2002000016

GLAD HANDS AND 7- WAY CONNECTOR

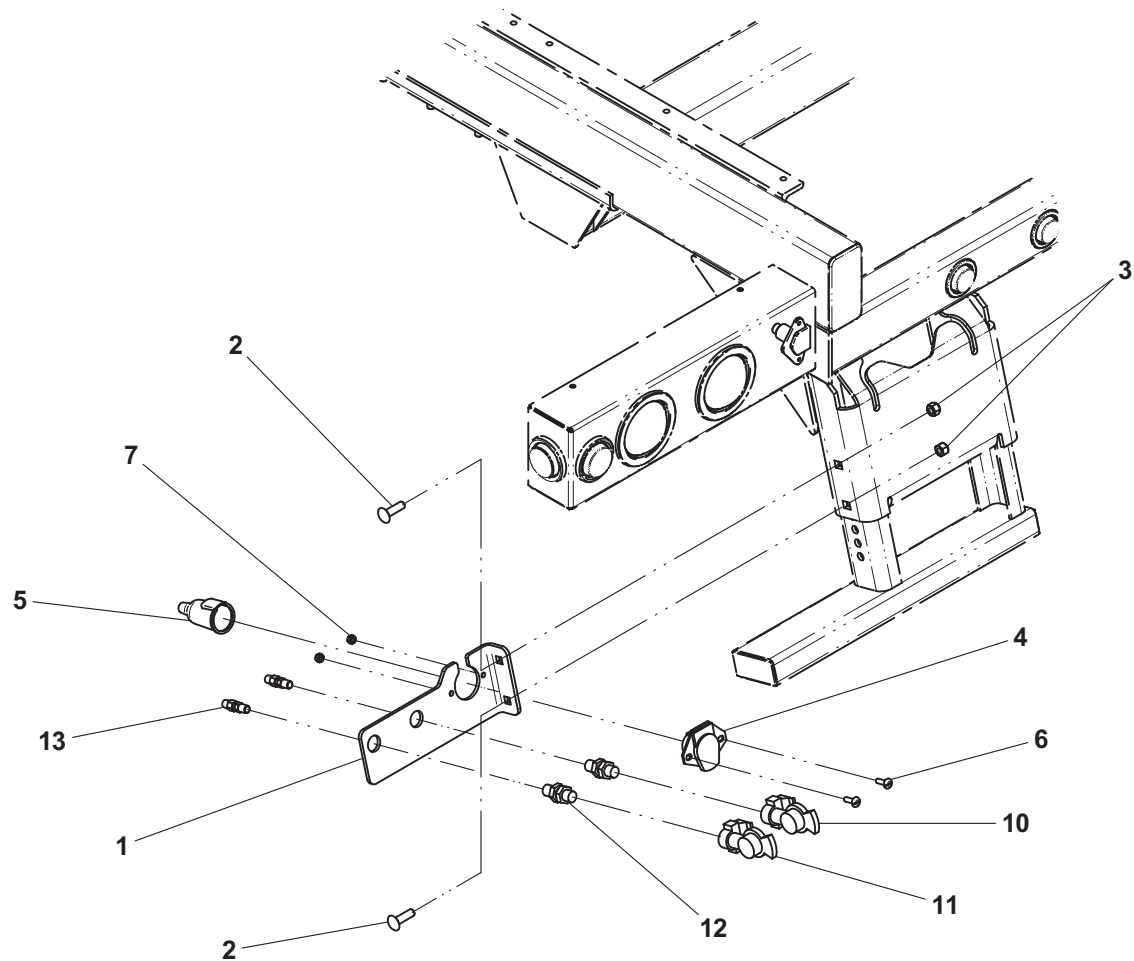

Item #8 Electrical Adapter 7 to 4 Way not shown
Item #9 Electrical Adapter 7 to 6 Way not shown
Item #14, Seal Kit Gladhand; #15, Airline Tubing; & #16, Union not shown

AIR SUPPLY DISCONNECT

ITEM	PART NO.	DESCRIPTION	QTY
1	7312000017	Coupling	1
2	7445080853	Elbow	1
3	7446502518	Bulkhead Fitting	1
4	7443000111	Elbow	1
5	7446382506	Connector	1
6	7565000014	Airline Tubing	32 ft
7	7935000120	Air Valve	1
8	7443000154	Bushing	1
9	7443000156	Nipple	1
10	7894000031	Cable Tie	6
11	7443000366	Fitting	1

AIR SUPPLY DISCONNECT

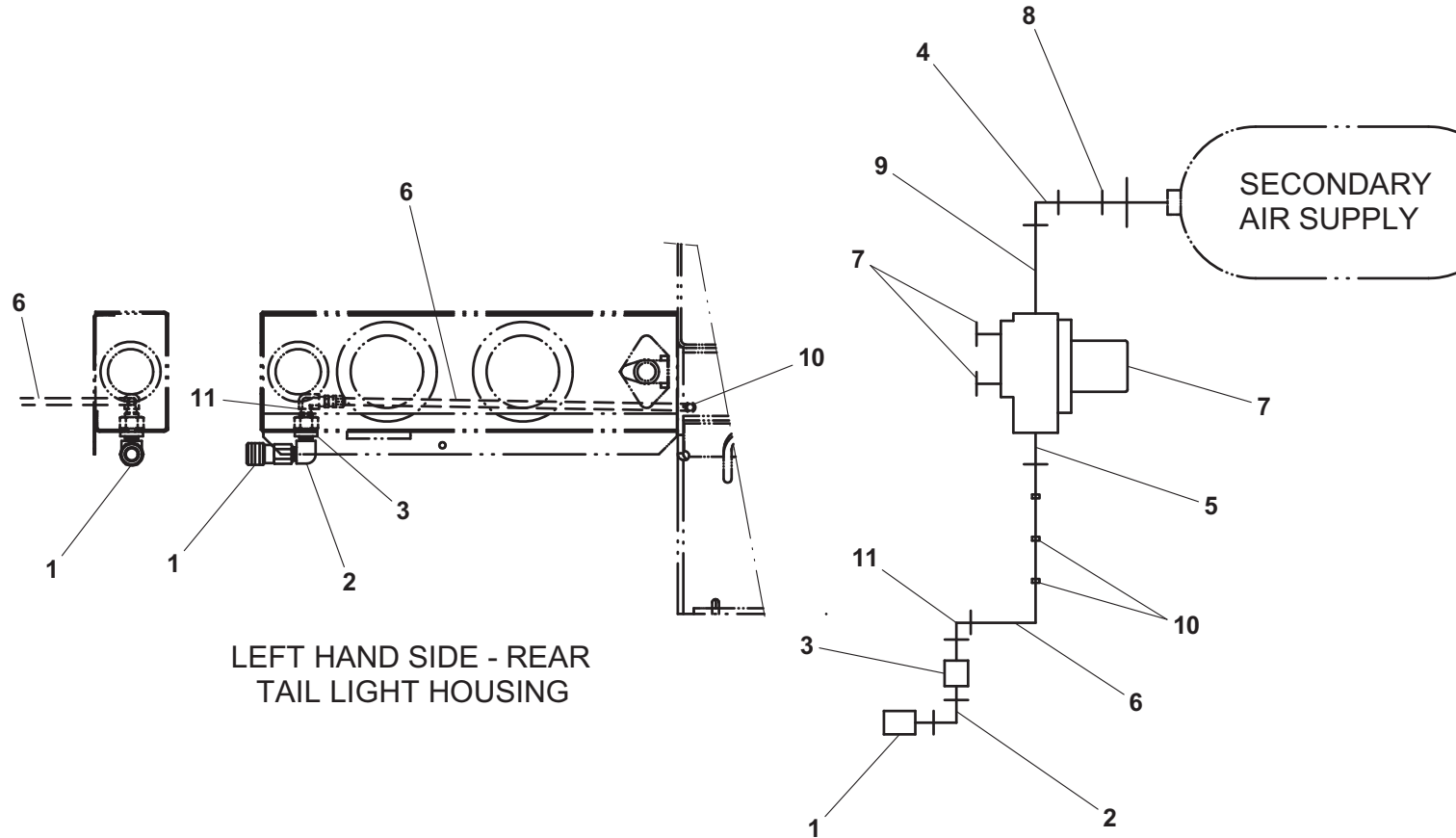

JUMP START KIT

ITEM	PART NO.	DESCRIPTION	QTY
1	7002000386	Jump Start Plug (IHC & Other)	1
	7002000385	Jump Start Plug (Ford & GM)	
2	4178000372	Bracket (Ford & Other)	1
	4178000202	Bracket (GM)	
3	4178000203	Bracket (GM)	1
	4706003210	Plate (Other)	
4	7110140605	Capscrew, 0.25"-20NC x 0.75" (Ford, GM & Other)	1
5	7950140161	Flatwasher, 0.25" ID (Ford & Other)	1
	7950140161	Flatwasher, 0.25" ID (IHC)	2
	7950140161	Flatwasher, 0.25" ID (GM)	3
6	7660142600	Locknut, 0.25"-20NC (Ford, GM & Other)	1
	7660142600	Locknut, 0.25"-20NC (IHC)	2
7	7115151064	Carriage Bolt, 0.31"-18NC x 1.25" (Other)	2
8	7950150161	Flatwasher, 0.31" ID (Other)	2
9	7660152601	Locknut, 0.31"-18NC (Other)	2
10	7115141450	Capscrew, 0.25"-20NC x 1.75" (IHC)	1
11	7115141650	Capscrew, 0.25"-20NC x 2.00" (IHC)	1
12	7660140000	Hex Nut, 0.25"-20NC (IHC)	1
	7660140000	Hex Nut, 0.25"-20NC (GM)	2
13	7111140850	Capscrew, 0.25"-20NC x 1.00" (GM)	2
14	7115181050	Capscrew, 0.50"-13NC x 1.25" (GM)	1
15	7950180153	Flatwasher, 0.50" ID (GM)	1
16	7660180000	Hex Nut, 0.50"-13NC (GM)	1

JUMP START KIT

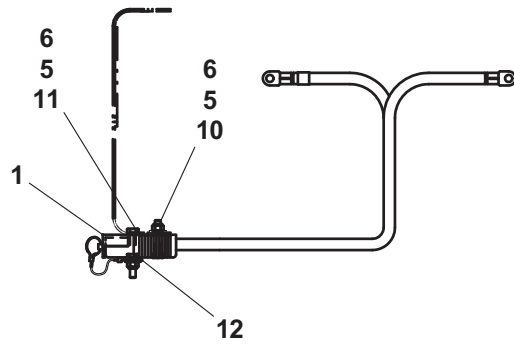

IHC FRONT BUMPER

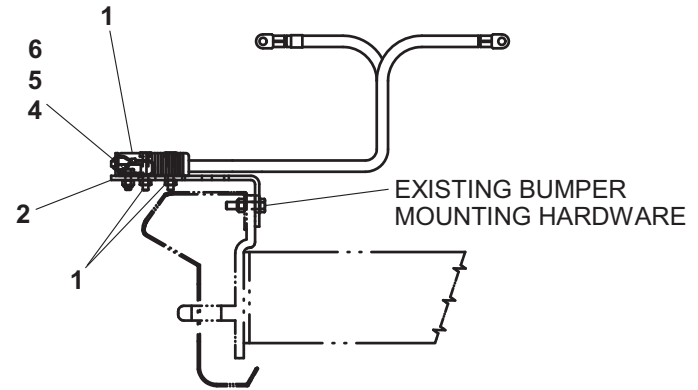

FORD FRONT BUMPER

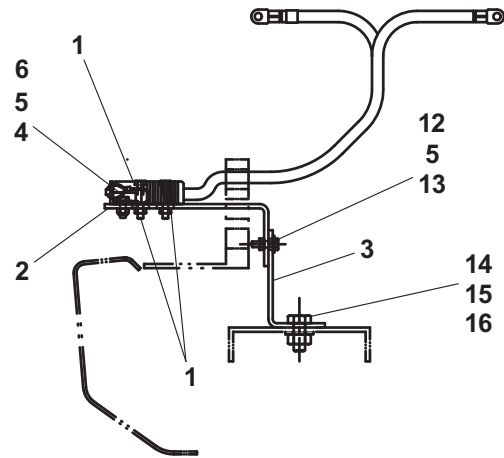

CHEVY FRONT BUMPER

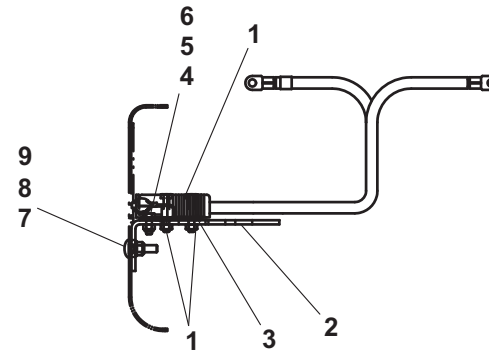

ALL OTHER FRONT BUMPERS

FOLDING DECK LADDER

ITEM	PART NO.	DESCRIPTION	QTY
1	3178000555	Bracket Weld	1
2	3002000009	Ladder Top Weld	1
3	3002000008	Ladder Bottom Weld	1
4	7114181418	Capscrew, 0.50"-13NC x 1.75"	4
5	7950180141	Flatwasher, 0.50" ID	12
6	7660182601	Locknut, 0.50"-13NC	4
7	7115180606	Shoulder Bolt, 0.50"-13NC x 0.75"	2
8	7950160161	Flatwasher, 0.38" ID	2
9	7660162601	Locknut, 0.38"-16NC	2

FOLDING DECK LADDER

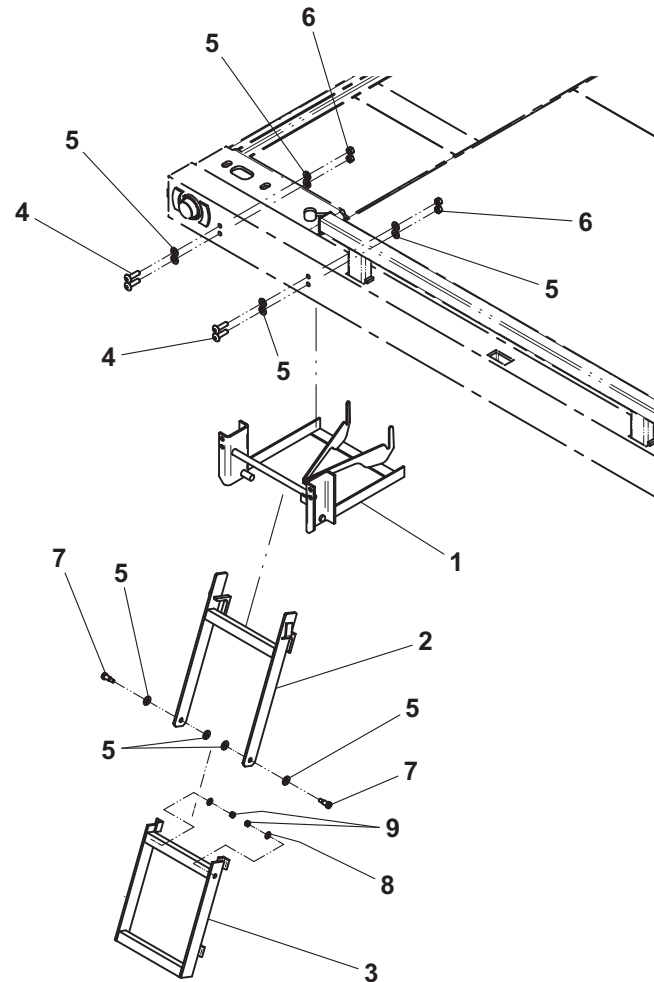

CHAINS AND STRAPS

ITEM	PART NO.	DESCRIPTION	QTY
1	7262000022*	Winch V-Chain	1
2	7262000056*	Front Tie-Down Chain	2
3	7894000019*	Rear Tie-Down Strap	2
4	7894000020*	Rear Tie Down Ratchet	2
5	7262000040	Wheel Lift Chain	2
6	7894000034+	Wheel Lift Tire Strap	2
7	7262000010	Towbar Chain	2
8	7894000058^	Tire Strap (hydraulic grid)	1
9	7894000059^	Choker (hydraulic grid)	1
10	7894000028^	Ratchet (hydraulic grid)	1
11	7561000024^	Forged Hook (hydraulic grid)	1
12	7115181664	Carriage Bolt, 0.50"-13NC x 2.00"	2
13	7660180001	Nut, 0.50"-13NC	2
14	7660182601	Locknut, 0.50"-13NC	2
15	5525000752	Magnetic Tow Lights	1
16	7894000073	8 Point Tie-Down Kit	1

* also available in Deck Chain / Tie-Down Kit, P/N 7577000208

^ also available in Hydraulic Grid Wheel Lift Tie-Down Kit, P/N 7577000376

+ also available in Wheel Lift Tie-Down Strap and Ratchet Kit, P/N 7577000242

CHAINS AND STRAPS

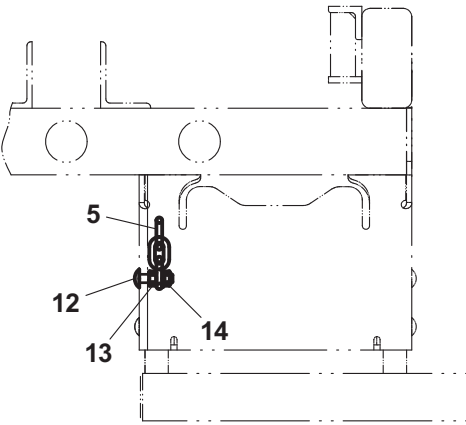
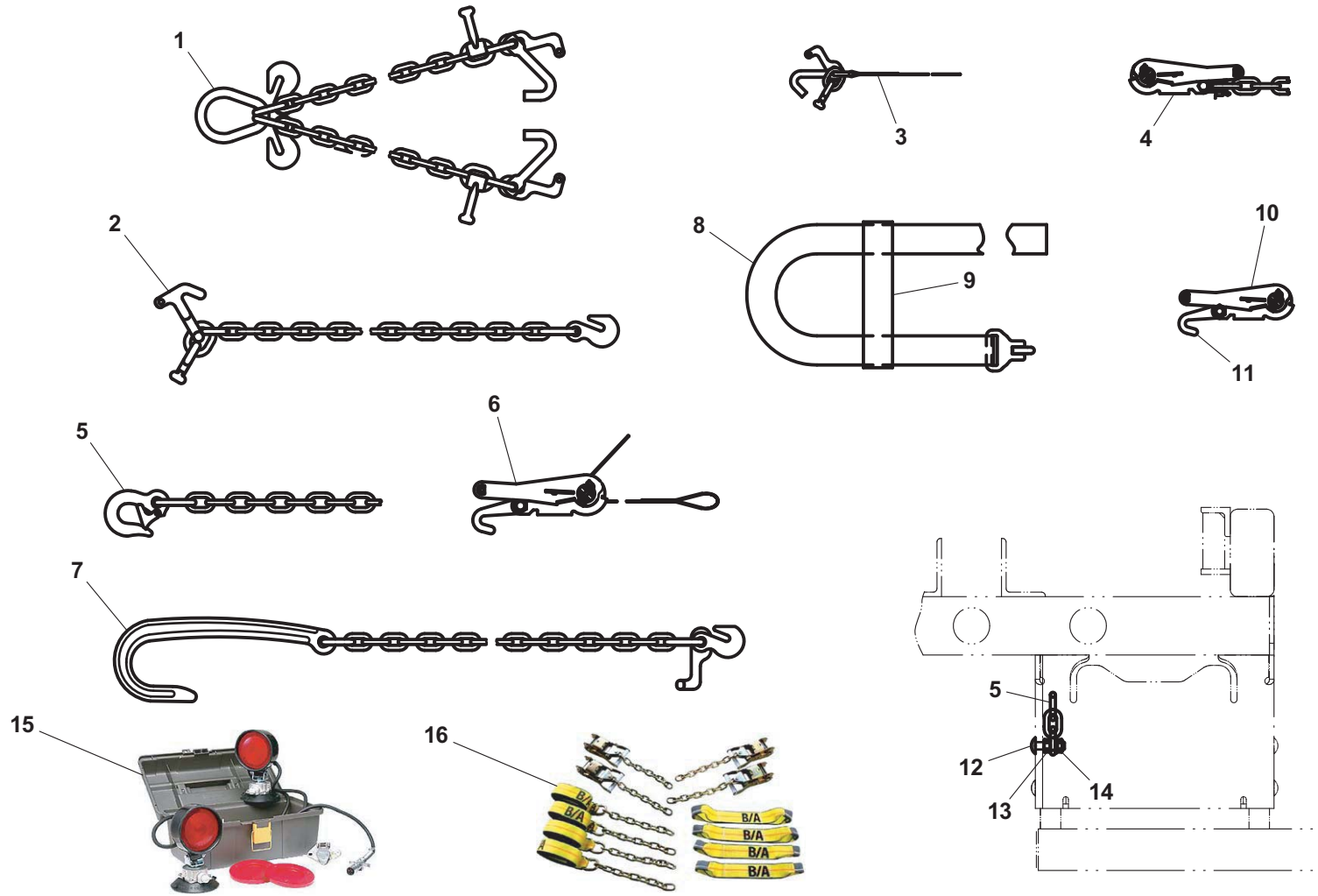

CHAIN BOX AT REAR OF SUBFRAME

DECALS

ITEM	PART NO.	DESCRIPTION	QTY
1	1001127221	Serial Number Tag	1
2	7330000338	Subframe / Patent Tag	1
3	7330000502	Decal - Slide Pad / Pivot Joint	1
4	7330000159	STAR Placard	1
5	7330000275	Decal - Operator's Pre-Checklist	1
6	7330000242	Decal - Free Spool (bolt-on headboard)	1
	7330000495	Decal - Free Spool (stationary headboard)	
7	7330000478	Decal - Lubrication Chart	1
8	7330000012	Decal - Winch	1
9	7330000433	Jerr-Dan Nameplate	3
10	7330000143	Decal - Made In The USA	1
11	7330000044	Decal - Align Arrow, Red	2
	7330000045	Decal - Align Arrow, White	
12	7330000272	Decal - Oil Level	1
13	7330000330	Decal - Cable Track	1
14	7330000139	Decal - Checklist Reminder	1
15	7330000684	Decal - Safety	1
16	7330000683	Decal - Safety	2
17	7330000060	Decal - Wheel Lift Hitch	1
18	7330000036	Secure Vehicle	2
19	7330000176	Decal - Air Suspension	1
20	7330000274	Decal - Overloading Tow Option	1
21	7330000599	Decal - Pinch Point	3
22	9330740009	Decal Kit - Muncie PTO	1
23	7759000004	Pop Rivet	12
24	7330000675	Decal - Air Free Spool Control, LH	1
25	7330000676	Decal - Air Free Spool Control, RH	1
26	7330000176	Decal - Air Suspension	1

DECALS

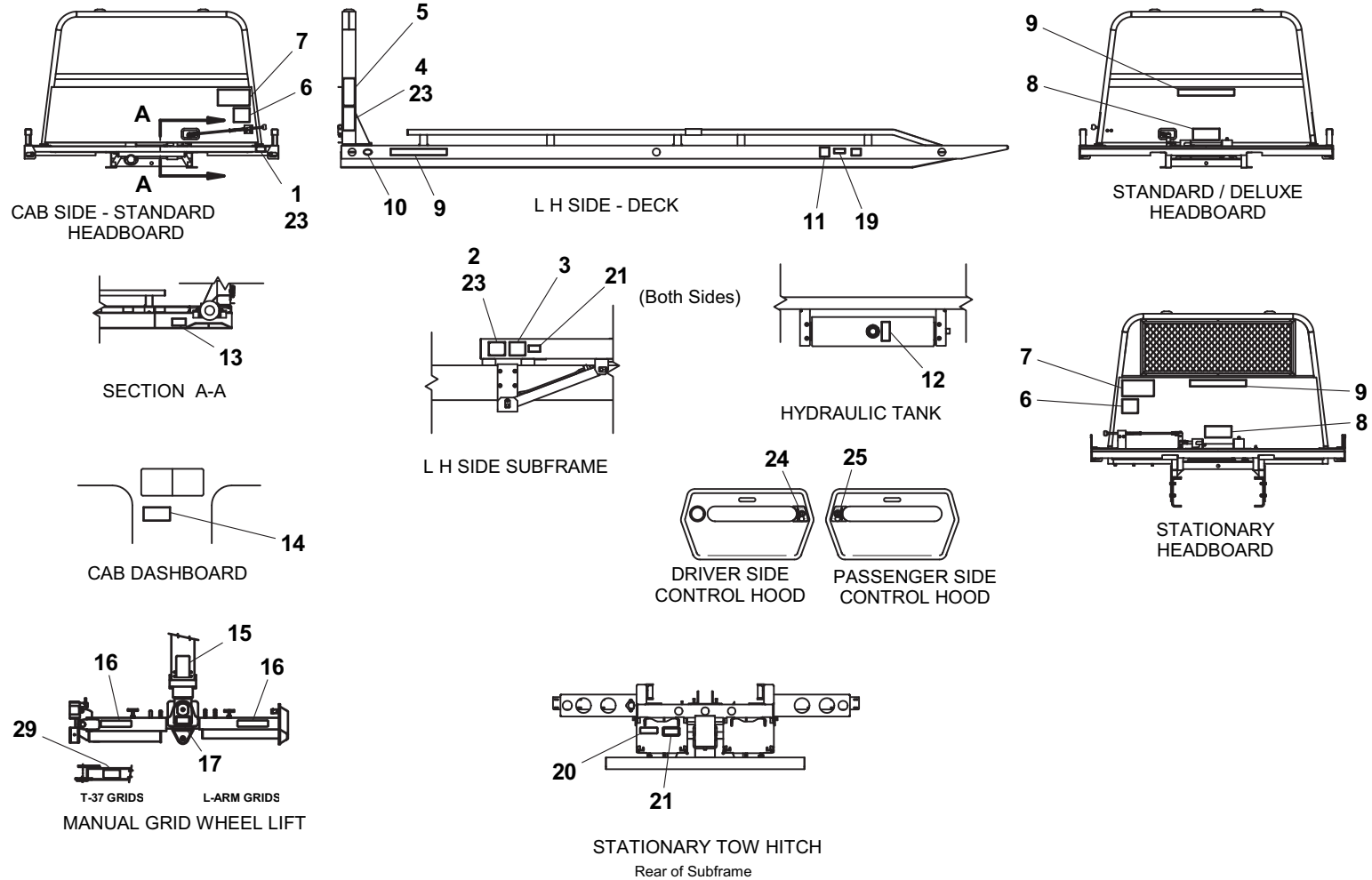

Items #22, Decal Kit - Munice PTO, not shown

ACCESSORY EQUIPMENT

ITEM	PART NO.	DESCRIPTION	QTY
1	7002000449	Magnetic Tow Lights	1
2	7002000404	Fire Extinguisher	1
3	7002000448	Wheel Chock	1
4	7002000285	Reflective Triangles	1
5	7002000451	Load Binder - 0.38" Chain	1
6	Not Required		
7	7002000521	Remote Control Transmitter Holder	1
8	7002000447	Valve Stem Extension Kit	1
9	7002000503	Air Compressor with Hose Reel	1
10	7443000111	Elbow	1
11	7115161050	Capscrew, 0.38"-16NC x 1.25"	4
12	7950150161	Flatwasher, 0.31" ID	4
13	7660162601	Locknut, 0.38"-16NC	4
14	7115181050	Capscrew, 0.50"-13NC x 1.25"	4
15	7950180153	Flatwasher, 0.50" ID	8
16	7660182601	Locknut, 0.50"-13NC	4

ACCESSORY EQUIPMENT

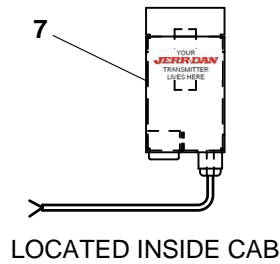
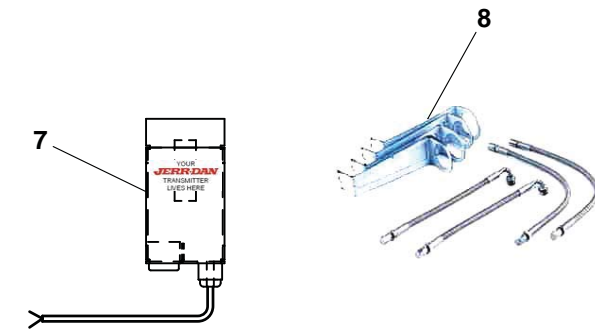
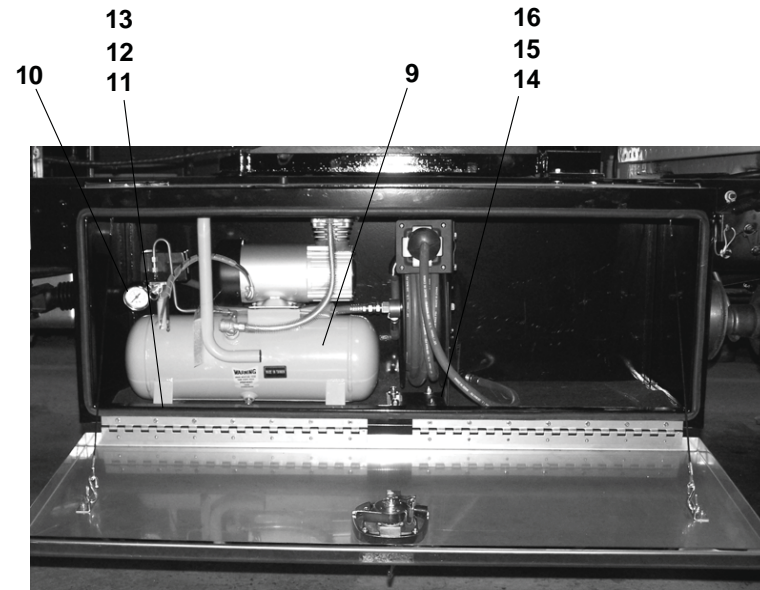
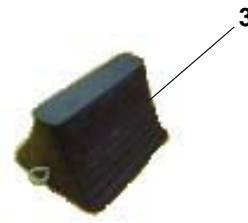

LOCATED INSIDE CAB

SHOWN MOUNTED INSIDE 48" TOOLBOX

HYDRAULIC SCHEMATIC

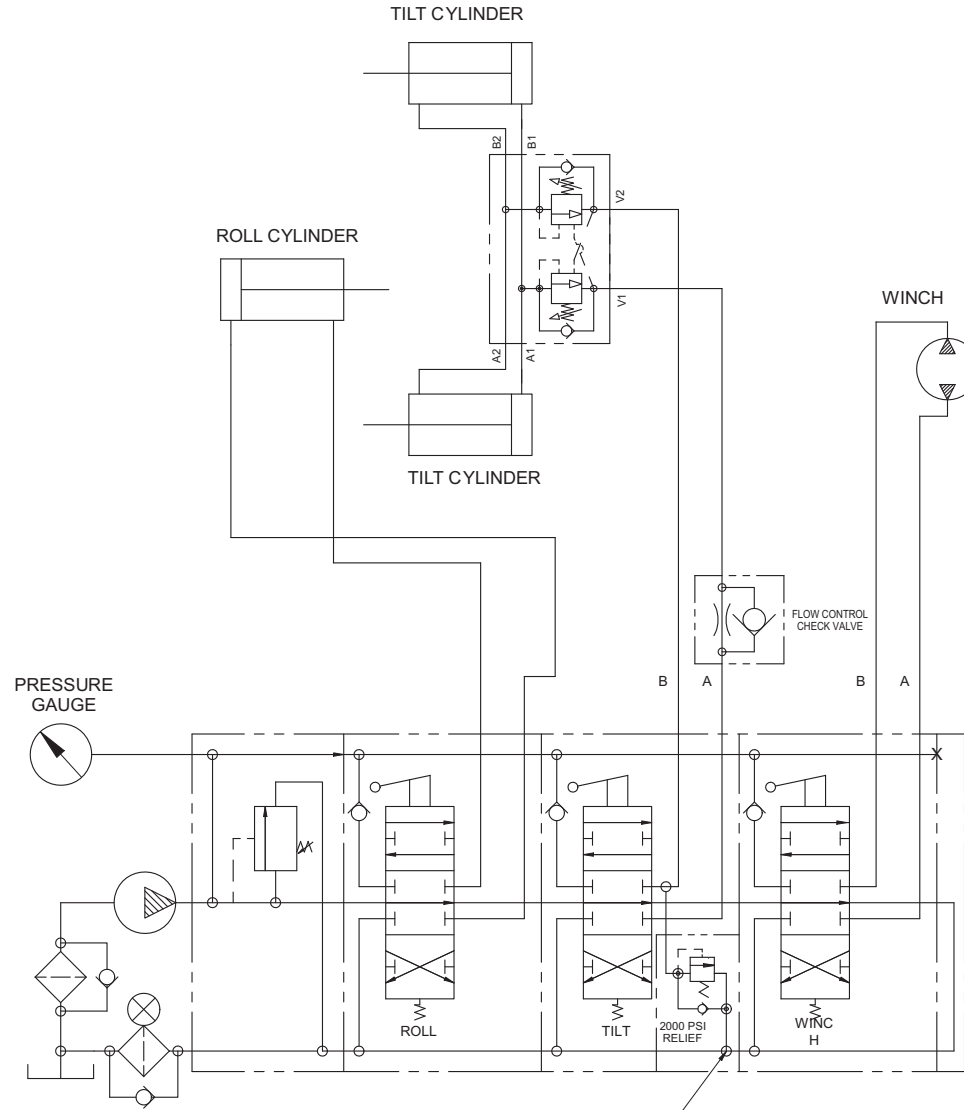

3 Bank Control Valve - No Tow Option

TILT RELIEF ON
UNITS WITH INBOARD
TILT CYLINDERS ONLY

HYDRAULIC SCHEMATIC

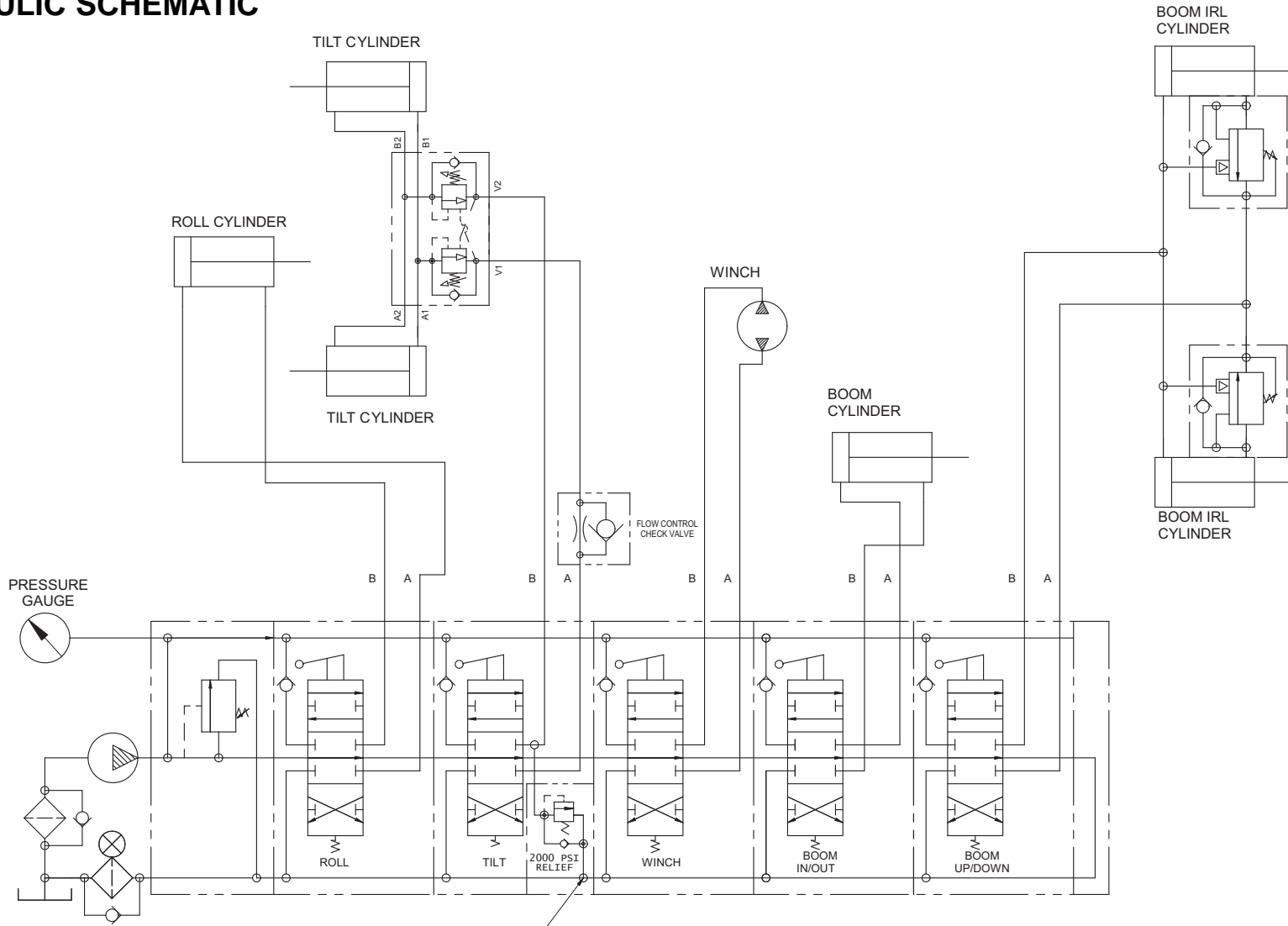

5 Bank Control Valve - IRL Tow Option

TILT RELIEF ON
UNITS WITH INBOARD
TILT CYLINDERS ONLY

HYDRAULIC SCHEMATIC

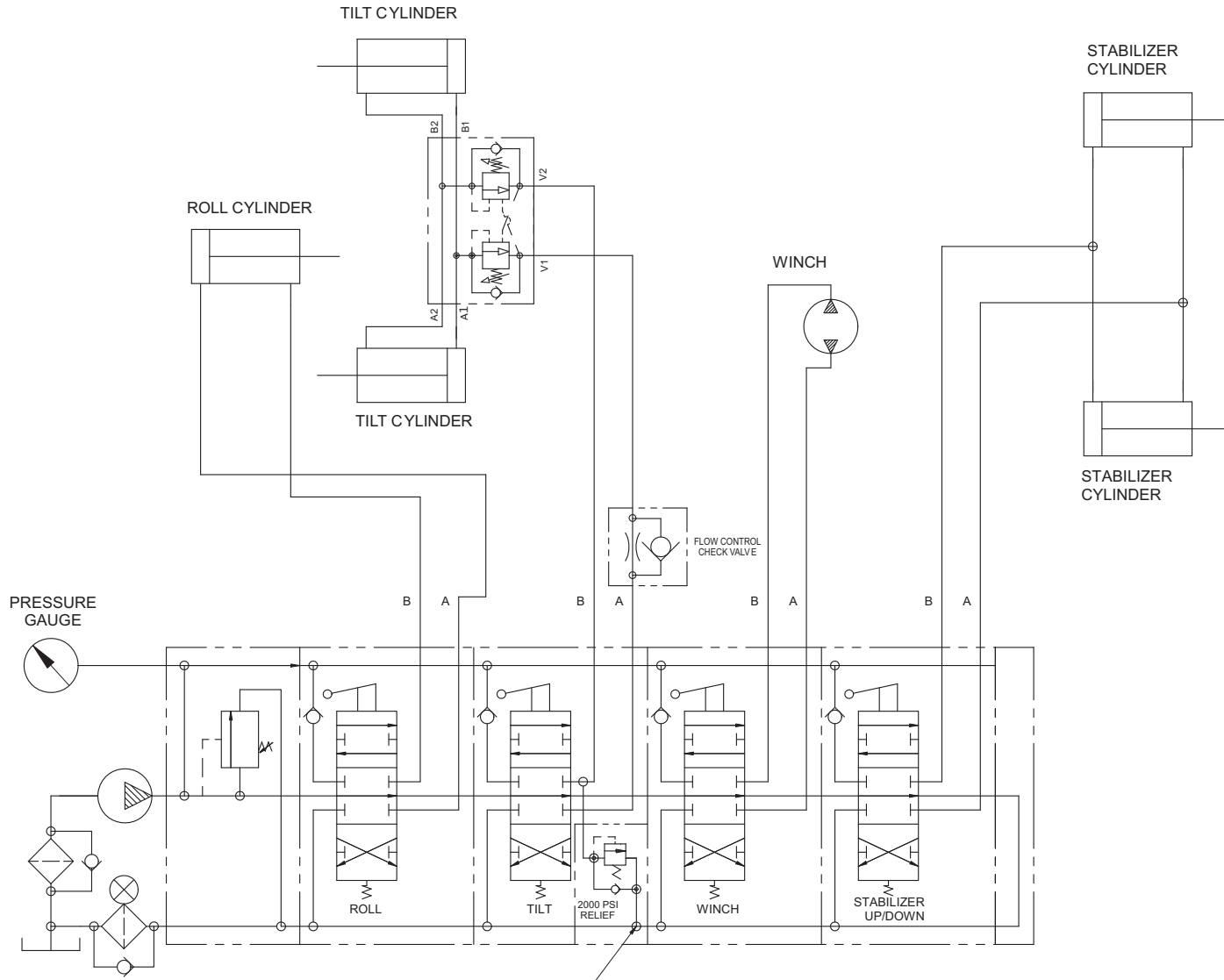

4 Bank Control Valve - Stabilizer Option

TILT RELIEF ON
UNITS WITH INBOARD
TILT CYLINDERS ONLY

HYDRAULIC SCHEMATIC

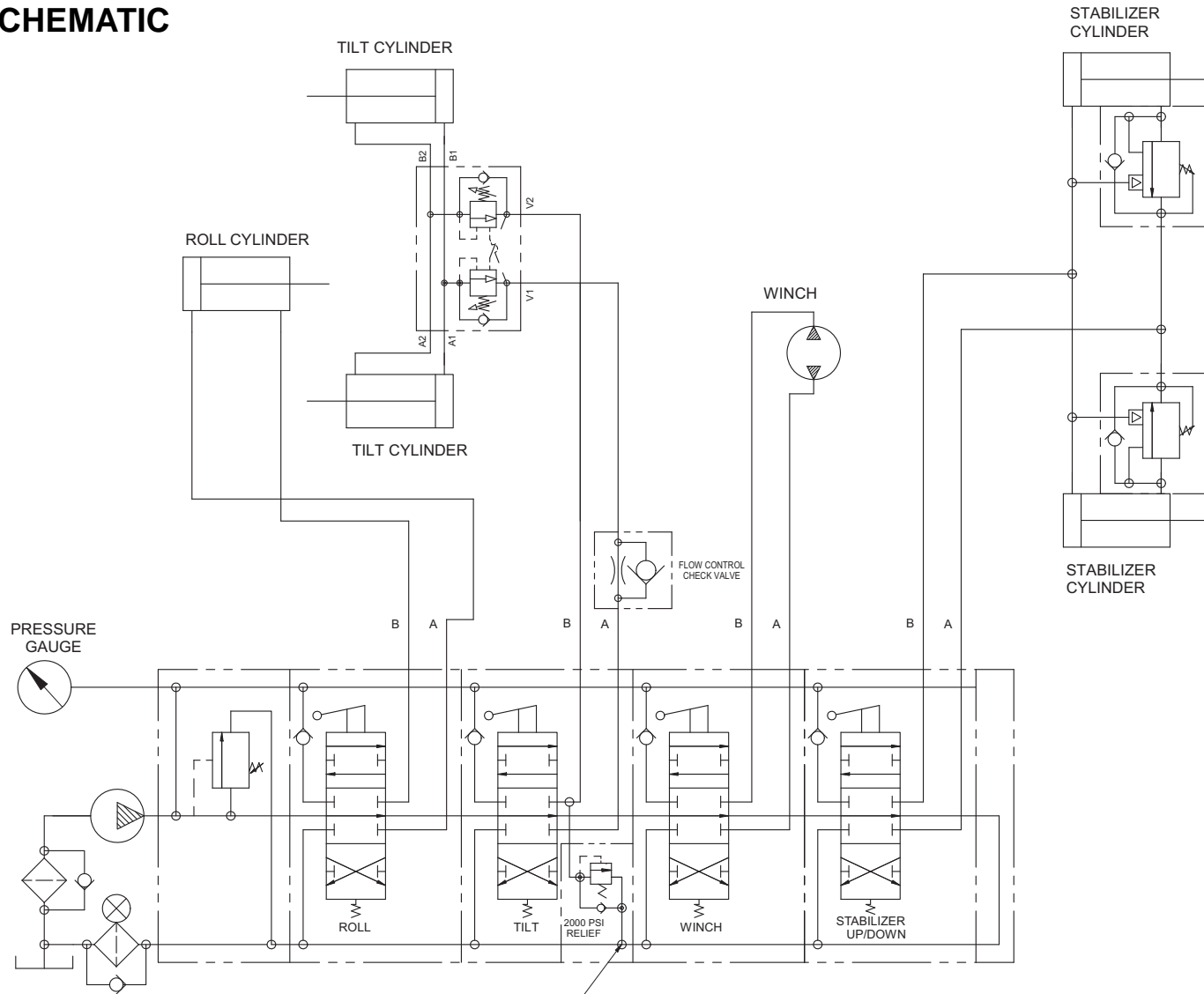

4 Bank Control Valve - Stabilizer with Tow Option

TILT RELIEF ON
UNITS WITH INBOARD
TILT CYLINDERS ONLY

THIS PAGE INTENTIONALLY LEFT BLANK

ELECTRICAL SCHEMATIC

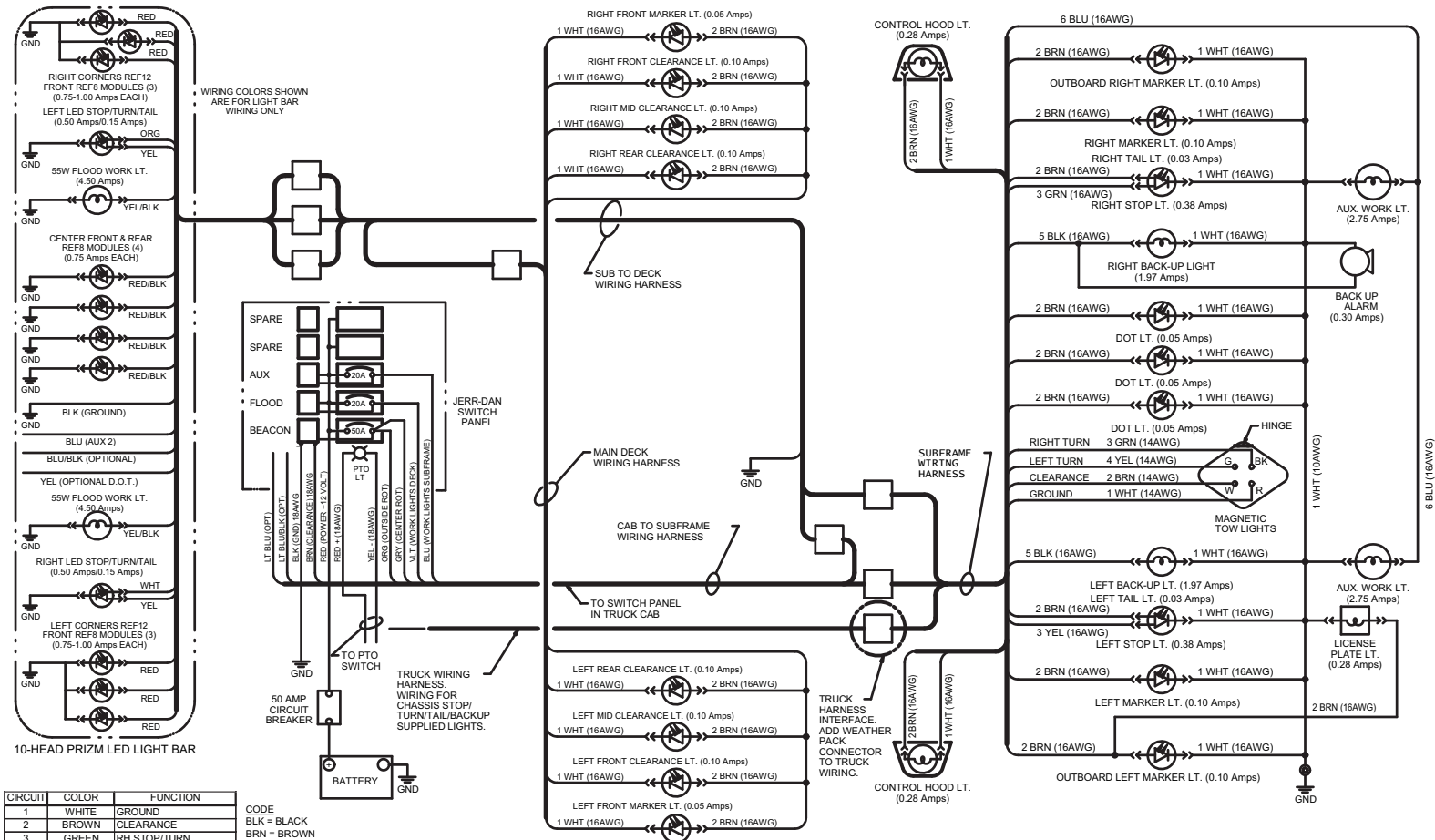

CIRCUIT	COLOR	FUNCTION
1	WHITE	GROUND
2	BROWN	CLEARANCE
3	GREEN	RH STOP/TURN
4	YELLOW	LH STOP/TURN
5	BLACK	BACK-UP
6	BLUE	WORK LIGHTS (SUBFR)
7	VIOLET	WORK LIGHTS (LT-BAR)
8	GRAY	BEACON (ROTATORS)
9	ORANGE	AUX 1 (FLASHER)
10	LT BLUE/BLACK	OPTION
11	LT BLUE	AUX 2

CODE	DESCRIPTION
BLK	BLACK
BRN	BROWN
BLU	BLUE
GRN	GREEN
RED	RED
YEL	YELLOW
LT	LIGHT
GRY	GRAY
ORG	ORANGE
VLT	VIOLET
WHT	WHITE

THIS PAGE INTENTIONALLY LEFT BLANK

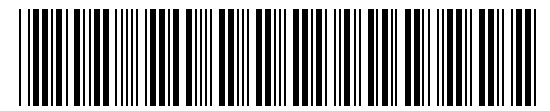

5376000140-0